

Test of NetScout Systems Inc. SENSOR4 Product
Family

To: FCC 47 CFR Part 15.407 & IC RSS-247

Test Report Serial No.: NTCT77-U3 Rev A



TEST REPORT

FROM



Test of NetScout Systems Inc. SENSOR4 Product Family

to

To FCC 47 CFR Part 15.407 & IC RSS-247

Test Report Serial No.: NTCT77-U3 Rev A

This report supersedes FLUK07-U3 Rev A

Applicant: NetScout Systems Inc
178 E. Tasman Drive.
Santa Jose
California 95134, USA

Product Function: Wireless LAN Client

Copy No: pdf Issue Date: 12th December 2016

This Test Report is Issued Under the Authority of:

MiCOM Labs, Inc.
575 Boulder Court
Pleasanton, California 94566
USA
Phone: +1 (925) 462-0304
Fax: +1 (925) 462-0306
www.micomlabs.com



MiCOM Labs is an ISO 17025 Accredited Testing Laboratory



Title: NetScout Systems Inc. SENSOR4 Product Family
To: FCC 47 CFR Part 15.407 & IC RSS-247
Serial #: NTCT77-U3 Rev A
Issue Date: 12th December 2016
Page: 3 of 269

This page has been left intentionally blank

This test report may be reproduced in full only. The document may only be updated by MiCOM Labs personnel. Any changes will be noted in the Document History section of the report.



TABLE OF CONTENTS

COVER PAGE	1
TITLE PAGE	2
ACCREDITATION, LISTINGS & RECOGNITION	5
TESTING ACCREDITATION	5
RECOGNITION.....	6
PRODUCT CERTIFICATION	7
1. TEST RESULT CERTIFICATE	9
2. REFERENCES AND MEASUREMENT UNCERTAINTY	10
2.1. Normative References	10
2.2. Test and Uncertainty Procedures	11
3. PRODUCT DETAILS AND TEST CONFIGURATIONS	12
3.1. Technical Details.....	12
3.2. Scope of Test Program	13
3.3. Equipment Model(s) and Serial Number(s).....	21
3.4. Antenna Details.....	21
3.5. Cabling and I/O Ports.....	22
3.6. Test Configurations.....	23
3.7. Equipment Modifications	24
3.8. Deviations from the Test Standard	27
3.9. Subcontracted Testing or Third Party Data.....	27
4. TEST SUMMARY	28
1. TEST EQUIPMENT CONFIGURATION(S)	30
1.1. Radiated Emissions - 3m Chamber	30
1.2. Conducted	33
1.3. DFS - Conducted	35
5. TEST RESULTS	37
5.1. Device Characteristics	37
5.1.1. <i>26 dB and 99 % Bandwidth</i>	37
5.1.2. <i>Transmit Output Power</i>	92
5.1.3. <i>Peak Power Spectral Density</i>	107
5.1.4. <i>Frequency Stability</i>	162
5.1.5. <i>Radiated Emissions</i>	163
5.1.6. <i>AC Wireline Conducted Emissions (150 kHz – 30 MHz)</i>	249
5.2. DFS (Dynamic Frequency Selection)	254
5.2.1. <i>DFS Test Program Details</i>	262
5.2.2. <i>Dynamic Frequency Selection (DFS) Test Results</i>	263
PHOTOGRAPHS	266
Conducted Test Setup	266
Radiated Emissions below 1GHz	267
Radiated Emissions above 1GHz.....	268

This test report may be reproduced in full only. The document may only be updated by MiCOM Labs personnel. Any changes will be noted in the Document History section of the report.



Title: NetScout Systems Inc. SENSOR4 Product Family
To: FCC 47 CFR Part 15.407 & IC RSS-247
Serial #: NTCT77-U3 Rev A
Issue Date: 12th December 2016
Page: 5 of 269

ACCREDITATION, LISTINGS & RECOGNITION

TESTING ACCREDITATION

MiCOM Labs, Inc. an accredited laboratory complies with the international standard BS EN ISO/IEC 17025. The company is accredited by the American Association for Laboratory Accreditation (A2LA) www.a2la.org test laboratory number 2381.01. MiCOM Labs test schedule is available at the following URL; <http://www.a2la.org/scopepdf/2381-01.pdf>



Accredited Laboratory

A2LA has accredited

MICOM LABS

Pleasanton, CA

for technical competence in the field of

Electrical Testing

This laboratory is accredited in accordance with the recognized International Standard ISO/IEC 17025:2005 *General requirements for the competence of testing and calibration laboratories*. This accreditation demonstrates technical competence for a defined scope and the operation of a laboratory quality management system (refer to joint ISO-ILAC-IAF Communiqué dated 8 January 2009).



Presented this 4th day of February 2016.

Senior Director of Quality & Communications
For the Accreditation Council
Certificate Number 2381.01
Valid to November 30, 2017

For the tests or types of tests to which this accreditation applies, please refer to the laboratory's Electrical Scope of Accreditation.



This test report may be reproduced in full only. The document may only be updated by MiCOM Labs personnel. Any changes will be noted in the Document History section of the report.



RECOGNITION

MiCOM Labs, Inc has widely recognized Electrical testing capabilities. Our international recognition includes Conformity Assessment Body designation by APEC MRA** countries. Our test reports are widely accepted for global type approvals.

Country	Recognition Body	Status	Phase	Identification No.
USA	Federal Communications Commission (FCC)	TCB	-	US0159 Listing #: 102167
Canada	Industry Canada (IC)	FCB	APEC MRA 2	US0159 Listing #: 4143A-2 4143A-3
Japan	MIC (Ministry of Internal Affairs and Communication)	CAB	APEC MRA 2	RCB 210
	VCCI	--	--	A-0012
Europe	European Commission	NB	EU MRA	NB 2280
Australia	Australian Communications and Media Authority (ACMA)	CAB	APEC MRA 1	US0159
Hong Kong	Office of the Telecommunication Authority (OFTA)	CAB	APEC MRA 1	
Korea	Ministry of Information and Communication Radio Research Laboratory (RRL)	CAB	APEC MRA 1	
Singapore	Infocomm Development Authority (IDA)	CAB	APEC MRA 1	
Taiwan	National Communications Commission (NCC) Bureau of Standards, Metrology and Inspection (BSMI)	CAB	APEC MRA 1	
Vietnam	Ministry of Communication (MIC)	CAB	APEC MRA 1	

**APEC MRA – Asia Pacific Economic Community Mutual Recognition Agreement.

Is a recognition agreement under which test lab is accredited to regulatory standards of the APEC member countries.

Phase I - recognition for product testing

Phase II – recognition for both product testing and certification

N/A – Not Applicable

**EU MRA – European Union Mutual Recognition Agreement.

Is a recognition agreement under which test lab is accredited to regulatory standards of the EU member countries.

**NB – Notified Body

This test report may be reproduced in full only. The document may only be updated by MiCOM Labs personnel. Any changes will be noted in the Document History section of the report.



Title: NetScout Systems Inc. SENSOR4 Product Family
To: FCC 47 CFR Part 15.407 & IC RSS-247
Serial #: NTCT77-U3 Rev A
Issue Date: 12th December 2016
Page: 7 of 269

PRODUCT CERTIFICATION

MiCOM Labs, Inc. is an accredited Product Certification Body per the international standard ISO/IEC 17065:2012. The company is accredited by the American Association for Laboratory Accreditation (A2LA) www.a2la.org test laboratory number 2381.02. MiCOM Labs test schedule is available at the following URL; <http://www.a2la.org/scopepdf/2381-02.pdf>



Accredited Product Certification Body

A2LA has accredited

MICOM LABS

Pleasanton, CA

This product certification body is accredited in accordance with the recognized International Standard ISO/IEC 17065:2012 *Requirements for bodies certifying products, processes and services*. This accreditation demonstrates technical competence for a defined scope and the operation of a management system.



Presented this 4th day of February 2016.

Senior Director of Quality & Communications
For the Accreditation Council
Certificate Number 2381.02
Valid to November 30, 2017

For the product certification schemes to which this accreditation applies, please refer to the organization's Product Certification Scope of Accreditation.

United States of America – Telecommunication Certification Body (TCB)

TCB Identifier – US0159

Industry Canada – Certification Body

CAB Identifier – US0159

Europe – Notified Body

Notified Body Identifier - 2280

Japan – Recognized Certification Body (RCB)

RCB Identifier - 210

This test report may be reproduced in full only. The document may only be updated by MiCOM Labs personnel. Any changes will be noted in the Document History section of the report.



Title: NetScout Systems Inc. SENSOR4 Product Family
To: FCC 47 CFR Part 15.407 & IC RSS-247
Serial #: NTCT77-U3 Rev A
Issue Date: 12th December 2016
Page: 8 of 269

DOCUMENT HISTORY

Document History		
Revision	Date	Comments
Company: Airmagnet		
Draft		
Rev A	4 th June 2012	Initial release.
Rev B	20 th June 2012	Clarification of antenna details.
Rev C	27 th August 2013	Included reference to:- a).. Single transmitting radio module FCC ID (RD7-SENSOR4X1) b).. dual transmitting radio module FCC ID: RD7-SENSOR4X
Company: Fluke		
Rev A	21 st November 2013	Report initially issued under Airmagnet (ARMG14-U2) manufacturer added new module variant to include cellular scanning function Added the following test results on the new variant a).. Radiated Emissions, Section 5.1.7 b).. ac Wireline Conducted Emissions, Section 5.1.8
Company: NetScout Systems		
Rev A	12 th December 2016	Retest; Spot checks on the original test results to verify compliance with the requirements of FCC Part 15.407 and RSS-247. Address the revised DFS requirements per FCC KDB 905462. Radiated Emission compliance as a result of changes to the enclosure..

This test report may be reproduced in full only. The document may only be updated by MiCOM Labs personnel. Any changes will be noted in the Document History section of the report.



Title: NetScout Systems Inc. SENSOR4 Product Family
To: FCC 47 CFR Part 15.407 & IC RSS-247
Serial #: NTCT77-U3 Rev A
Issue Date: 12th December 2016
Page: 9 of 269

1. TEST RESULT CERTIFICATE

Applicant:	NetScout Systems Inc 178 E. Tasman Drive. Santa Jose California 95134, USA	Tested By:	MiCOM Labs, Inc. 575 Boulder Court Pleasanton California, 94566, USA
EUT:	Product Description	Tel:	+1 925 462 0304
Model:	SENSOR4 Family	Fax:	+1 925 462 0306
S/N:	Engineering samples: Integral NG5-x & External NG5-y; 16291348	Website:	www.micomlabs.com
Test Date(s):	7th February - 17th May 2012; 4th - 15 November 2013; and 31st October - 7th November 2016		

STANDARD(S)	TEST RESULTS
FCC 47 CFR Part 15.407 & IC RSS-247	EQUIPMENT COMPLIES

MiCOM Labs, Inc. tested the equipment mentioned in accordance with the requirements set forth in the above standards. Test results indicate that the equipment tested is capable of demonstrating compliance with the requirements as documented within this report.

Notes:

1. This document reports conditions under which testing was conducted and the results of testing performed.
2. Details of test methods used have been recorded and kept on file by the laboratory.
3. Test results apply only to the item(s) tested.

Approved & Released for MiCOM Labs, Inc. by:

Graeme Grieve
Quality Manager MiCOM Labs, Inc.



Gordon Hurst
President & CEO MiCOM Labs, Inc.

This test report may be reproduced in full only. The document may only be updated by MiCOM Labs personnel. Any changes will be noted in the Document History section of the report.



Title: NetScout Systems Inc. SENSOR4 Product Family
To: FCC 47 CFR Part 15.407 & IC RSS-247
Serial #: NTCT77-U3 Rev A
Issue Date: 12th December 2016
Page: 10 of 269

2. REFERENCES AND MEASUREMENT UNCERTAINTY

2.1. Normative References

REF.	PUBLICATION	YEAR	TITLE
I	KDB 662911 D01 & D02	Oct 31 2013	Guidance for measurement of output emission of devices that employ single transmitter with multiple outputs or systems with multiple transmitters operating simultaneously in the same frequency band
II	KDB 905462 D07 v02	22 nd August 2016	Test guidance to demonstrate compliance for U-NII devices subject to DFS requirements.
III	KDB 926956 D01 v02	22 nd August 2016	U-NII Device Transition Plan
IV	KDB 789033 D02 v01r03	22 nd August 2016	General UNII Test Procedures New Rules
V	A2LA	June 2015	R105 - Requirement's When Making Reference to A2LA Accreditation Status
VI	ANSI C63.10	2013	American National Standard for Testing Unlicensed Wireless Devices
VII	ANSI C63.4	2014	American National Standards for Methods of Measurement of Radio-Noise Emissions from Low-Voltage Electrical and Electronic Equipment in the Range of 9 kHz to 40 GHz
VIII	CISPR 22	2008	Information technology equipment - Radio disturbance characteristics - Limits and methods of measurement
IX	ETSI TR 100 028	2001-12	Parts 1 and 2 Electromagnetic compatibility and Radio Spectrum Matters (ERM); Uncertainties in the measurement of mobile radio equipment characteristics
X	FCC 06-96	Jun 30 2006	Memorandum Opinion and Order
XI	FCC 47 CFR Part 15.407	2014	Radio Frequency Devices; Subpart E –Unlicensed National Information Infrastructure Devices
XII	ICES-003	Issue 6 Jan 2016	Spectrum Management and Telecommunications; Interference-Causing Equipment Standard. Information Technology Equipment (Including Digital Apparatus) – Limits and methods of measurement.
XIII	M 3003	Edition 3 Nov.2012	Expression of Uncertainty and Confidence in Measurements
XIV	RSS-247 Issue 1	May 2015	Digital Transmission Systems (DTSS), Frequency Hopping System (FHSs) and Licence-Exempt Local Area Network (LE-LEN) Devices
XV	RSS-Gen Issue 4	November 2014	General Requirements and Information for the Certification of Radiocommunication Equipment
XVI	KDB 644545 D03 v01	August 14th 2014	Guidance for IEEE 802.11ac New Rules
XVII	FCC 47 CFR Part 2.1033	2014	FCC requirements and rules regarding photographs and test setup diagrams.
XVIII	EN 55022	2010 + AC:2011	Information technology equipment - Radio disturbance characteristics - Limits and methods of measurement

This test report may be reproduced in full only. The document may only be updated by MiCOM Labs personnel. Any changes will be noted in the Document History section of the report.



Title: NetScout Systems Inc. SENSOR4 Product Family
To: FCC 47 CFR Part 15.407 & IC RSS-247
Serial #: NTCT77-U3 Rev A
Issue Date: 12th December 2016
Page: 11 of 269

2.2. Test and Uncertainty Procedures

Conducted and radiated emission measurements were conducted in accordance with American National Standards Institute ANSI C63.4, listed in the Normative References section of this report.

Measurement uncertainty figures are calculated in accordance with ETSI TR 100 028 Parts 1 and 2.

Measurement uncertainties stated are based on a standard uncertainty multiplied by a coverage factor $k = 2$, providing a level of confidence of approximately 95 % in accordance with UKAS document M 3003 listed in the Normative References section of this report.

This test report may be reproduced in full only. The document may only be updated by MiCOM Labs personnel. Any changes will be noted in the Document History section of the report.



Title: NetScout Systems Inc. SENSOR4 Product Family
To: FCC 47 CFR Part 15.407 & IC RSS-247
Serial #: NTCT77-U3 Rev A
Issue Date: 12th December 2016
Page: 12 of 269

3. PRODUCT DETAILS AND TEST CONFIGURATIONS

3.1. Technical Details

Details	Description
Purpose:	Test of the NetScout Systems Inc. SENSOR4 Product Family in the frequency ranges 5,250 to 5,350 and 5,470 to 5,725 MHz to FCC Part 15.407 and Industry Canada RSS-247 regulations.
Applicant:	NetScout Systems Inc 178 E. Tasman Drive. Santa Jose California 95134, USA
Manufacturer:	As applicant
Laboratory performing the tests:	MiCOM Labs, Inc. 575 Boulder Court Pleasanton, California 94566 USA
Test report reference number:	NTCT77-U3 Rev A
Date EUT received:	Initial Test: 7th February 2012 New Cellular Variant: 15 th October 2013
Standard(s) applied:	FCC 47 CFR Part 15.407 & IC RSS-247
Dates of test (from - to):	7th February - 17th May 2012; 4th -15 November 2013; and 31st October - 7th November 2016 4th – 15th November 2013
No of Units Tested:	Two
Type of Equipment:	802.11a/b/g/n Wireless LAN Access Point, 3x3 Spatial Multiplexing MIMO configuration
Manufacturers Trade Name:	Wireless Client
Model(s):	Sensor4 Family
Location for use:	Indoor
Declared Frequency Range(s):	5,150 to 5,350 and 5,470 to 5,725 MHz
Software Release	Build 26809
Hardware Release:	assembly rev 5, pcb rev 3
Type of Modulation:	Per 802.11 – OFDM
EUT Modes of Operation:	Legacy 802.11a, 802.11n HT-20, HT-40
Transmit/Receive Operation:	Time Division Duplex
System Beam Forming:	Sensor4 has no capability for beam forming
Rated Input Voltage and Current:	12 Vdc 0.65 A: POE 48 Vdc 0.2A
Operating Temperature Range:	Declared range 0° to +55°C
ITU Emission Designator:	802.11a 18M8D1D 802.11n HT-20 19M9D1D 802.11n HT-40 36M7D1D
Equipment Dimensions:	7.5" x 7.5" x 1.5"
Weight:	1 lb (0.454 Kg)
Hardware Rev:	assembly rev 5, pcb rev 3
Software Rev:	Build 35232
Primary function of equipment:	WiFi scanning
Secondary function of equipment:	Spectrum analyzer

This test report may be reproduced in full only. The document may only be updated by MiCOM Labs personnel. Any changes will be noted in the Document History section of the report.



Title: NetScout Systems Inc. SENSOR4 Product Family
To: FCC 47 CFR Part 15.407 & IC RSS-247
Serial #: NTCT77-U3 Rev A
Issue Date: 12th December 2016
Page: 13 of 269

3.2. Scope of Test Program

The SENSOR4 wireless client was originally tested in the 5150 – 5350 MHz and 5470 - 5725 MHz bands by MiCOM Labs for compliance against FCC 47 CFR Part 15.247 and Industry Canada RSS-210 specifications in 2012 with updates in 2013 when testing was reported in MiCOM Labs in FLUK07-U3 report in November 2013.

The scope of this test program was to test the NetScout Systems Inc. SENSOR4 Product Family, 802.11 a/b/g/n Wireless client configurations in the frequency ranges 5150 – 5350 MHz and 5470 – 5725 MHz for compliance against FCC 47 CFR Part 15.407 and Industry Canada RSS-247 specifications per the following;-

1. Spot checks on the original test results to verify compliance with the requirements of FCC Part 15.407 and RSS-247.
2. Address the revised DFS requirements per FCC KDB 905462.
3. Radiated Emission compliance as a result of changes to the enclosure.

This test report may be reproduced in full only. The document may only be updated by MiCOM Labs personnel. Any changes will be noted in the Document History section of the report.



NetScout Systems Inc SENSOR4 Product Family

The SENSOR4 wireless client can be marketed using a number of different models.

The product was originally tested and certified in 2012 and 2013 for the 12 model variants listed in the table below.

Sensor Model	Features
SENSOR4-R1S0-I	AIRMAGNET SENSOR, 4TH GEN, 1 X 11N RADIO, INTERNAL ANTENNA.
SENSOR4-R1S1-I	AIRMAGNET SPECTRUM SENSOR, 4TH GEN, 1 X 11N RADIO, INTERNAL ANTENNA.
SENSOR4-R2S0-I	AIRMAGNET SENSOR, 4TH GEN, 2 X 11N RADIO, INTERNAL ANTENNA.
SENSOR4-R2S1-I	AIRMAGNET SPECTRUM SENSOR, 4TH GEN, 2 X 11N RADIO, INTERNAL ANTENNA.
SENSOR4-R1S0-E	AIRMAGNET SENSOR, 4TH GEN, 1 X 11N RADIO 4 EXTERNAL ANTENNAS.
SENSOR4-R1S1-E	AIRMAGNET SPECTRUM SENSOR, 4TH GEN, 1 X 11N RADIO 4 EXTERNAL ANTENNAS.
SENSOR4-R2S0-E	AIRMAGNET SENSOR, 4TH GEN, 2 X 11N RADIO 8 EXTERNAL ANTENNAS.
SENSOR4-R2S1-E	AIRMAGNET SPECTRUM SENSOR, 4TH GEN, 2 X 11N RADIO 8 EXTERNAL ANTENNAS.
SENSOR4-R1S1W1-E	AIRMAGNET WIFI SPECTRUM SENSOR, 4TH GEN, 1 x 11N Radio, CELLULAR SPECTRUM, 5 EXTERNAL ANTENNAS
SENSOR4-R1S0W1-E	AIRMAGNET SENSOR, 4TH GEN, 1 x 11N Radio, CELLULAR SPECTRUM, 5 EXTERNAL ANTENNAS
SENSOR4-R0S0W1-E	AIRMAGNET SENSOR, 4TH GEN, 1 x 11N Radio, CELLULAR SPECTRUM, 1 EXTERNAL ANTENNA
SENSOR4-R0S1W0-E	AIRMAGNET WIFI SPECTRUM SENSOR, 1 EXTERNAL ANTENNA

The test results reported in this document test worst case fully loaded configurations;

- SENSOR4-R2S1-E (external antenna)
- SENSOR4-R2S1-I (integral antenna)
- SENSOR4-R1S1W1-E (external antenna)

FCC OET KDB Implementation

This test program implements the following FCC KDB – 662911 D01 & D02.

Emissions Testing of Transmitters with Multiple Outputs in the Same Band

The KDB document provides guidance for measurements of conducted output emissions of devices that employ a single transmitter with multiple outputs in the same band, with the outputs occupying the same or overlapping frequency ranges. It applies to EMC compliance measurements on devices that transmit on multiple antennas simultaneously in the same or overlapping frequency ranges through a coordinated process. Examples include, but are not limited to, devices employing beam forming or multiple-input and multiple-output (MIMO.) This guidance applies to both licensed and unlicensed devices wherever the FCC rules call for conducted output measurements. Guidance is provided for in-band, out-of-band and spurious emission measurements.

This guidance does not apply to the multiple transmitters included in a composite device, such as a device that combines an 802.11 modem with a cell phone in one enclosure with each driving its own antenna.

NetScout Systems Inc. SENSOR4 Product Family Cellular version; External Top View



This test report may be reproduced in full only. The document may only be updated by MiCOM Labs personnel. Any changes will be noted in the Document History section of the report.



Title: NetScout Systems Inc. SENSOR4 Product Family
To: FCC 47 CFR Part 15.407 & IC RSS-247
Serial #: NTCT77-U3 Rev A
Issue Date: 12th December 2016
Page: 16 of 269

NetScout Systems Inc. SENSOR4 Product Family Cellular version; External Bottom View

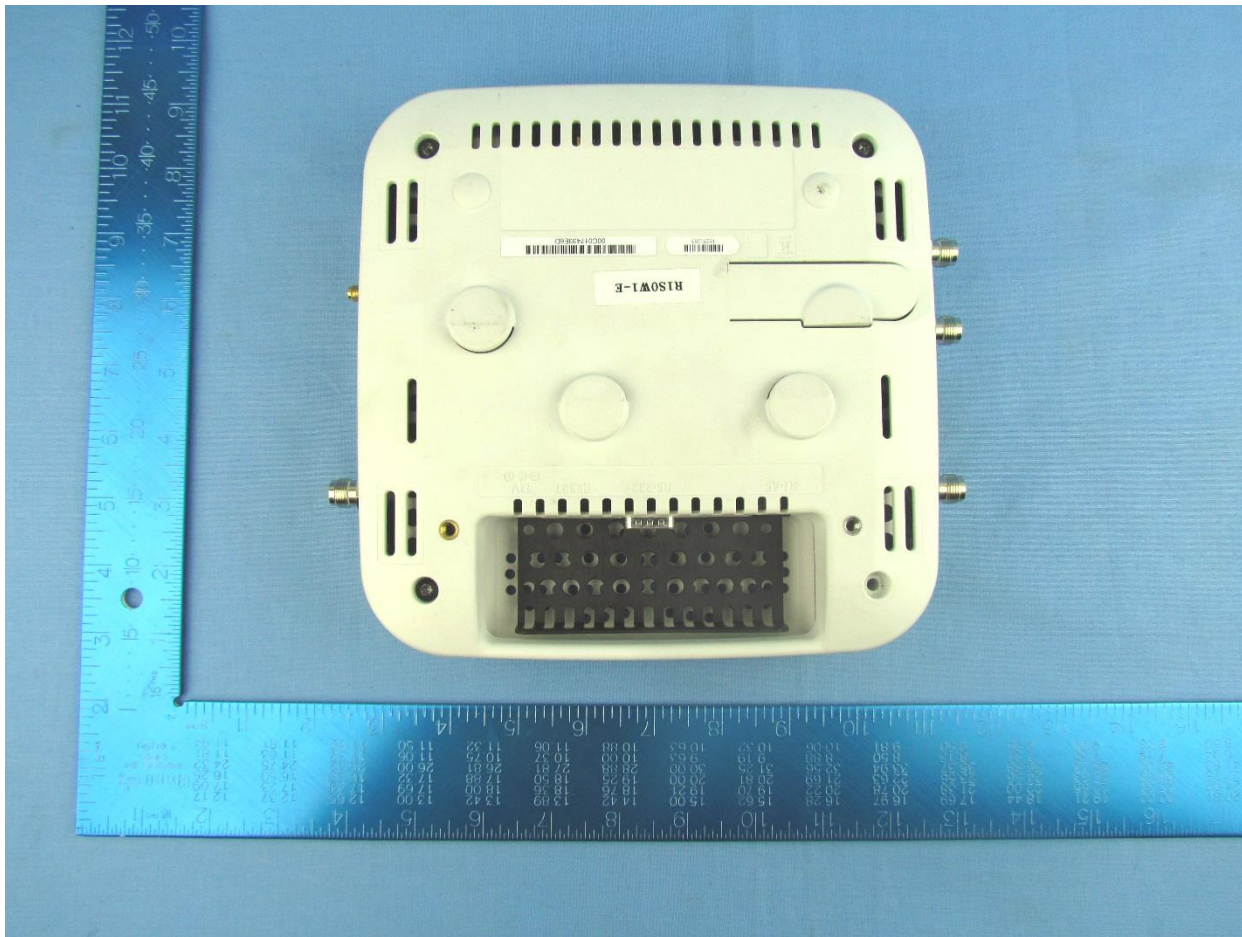

This test report may be reproduced in full only. The document may only be updated by MiCOM Labs personnel. Any changes will be noted in the Document History section of the report.



Title: NetScout Systems Inc. SENSOR4 Product Family
To: FCC 47 CFR Part 15.407 & IC RSS-247
Serial #: NTCT77-U3 Rev A
Issue Date: 12th December 2016
Page: 17 of 269

NetScout Systems Inc. SENSOR4 Product Family Cellular version; Front View



This test report may be reproduced in full only. The document may only be updated by MiCOM Labs personnel. Any changes will be noted in the Document History section of the report.



Title: NetScout Systems Inc. SENSOR4 Product Family
To: FCC 47 CFR Part 15.407 & IC RSS-247
Serial #: NTCT77-U3 Rev A
Issue Date: 12th December 2016
Page: 18 of 269

NetScout Systems Inc. SENSOR4 Product Family Cellular version; External rear View



This test report may be reproduced in full only. The document may only be updated by MiCOM Labs personnel. Any changes will be noted in the Document History section of the report.



Title: NetScout Systems Inc. SENSOR4 Product Family
To: FCC 47 CFR Part 15.407 & IC RSS-247
Serial #: NTCT77-U3 Rev A
Issue Date: 12th December 2016
Page: 19 of 269

NetScout Systems Inc. SENSOR4 Product Family Cellular version; External Left View



This test report may be reproduced in full only. The document may only be updated by MiCOM Labs personnel. Any changes will be noted in the Document History section of the report.



Title: NetScout Systems Inc. SENSOR4 Product Family
To: FCC 47 CFR Part 15.407 & IC RSS-247
Serial #: NTCT77-U3 Rev A
Issue Date: 12th December 2016
Page: 20 of 269

NetScout Systems Inc. SENSOR4 Product Family Cellular version; External Right View



This test report may be reproduced in full only. The document may only be updated by MiCOM Labs personnel. Any changes will be noted in the Document History section of the report.



Title: NetScout Systems Inc. SENSOR4 Product Family
To: FCC 47 CFR Part 15.407 & IC RSS-247
Serial #: NTCT77-U3 Rev A
Issue Date: 12th December 2016
Page: 21 of 269

XX

3.3. Equipment Model(s) and Serial Number(s)

Type (EUT/Support)	Equipment Description (Including Brand Name)	Mfr	Model No.	Serial No.
EUT	802.11a/b/g/n Wireless Access Point	Fluke Networks	SENSOR4 Family	Engineering samples: Integral NG5-x & External NG5-y; 16291348
EUT	POE	PowerDSine	PD-3501/AC	--
EUT	ac/dc Adaptor	Fairway Electronic 100-240Vac 50-60Hz 12Vdc, 1.66A	VE20-120	--
Support	Laptop PC	Dell	--	None

3.4. Antenna Details

Type	Manufacturer	Model	Family	Gain (dBi)	BF Gain	Dir BW	X-Pol	Frequency Band (MHz)
integral	Laird	Laird NanoGreen	Folded Dipole	4.8	-	360	-	5150 - 5250
integral	Laird	Laird NanoGreen	Folded Dipole	4.8	-	360	-	5250 - 5350
integral	Laird	Laird NanoGreen	Folded Dipole	4.8	-	360	-	5470 - 5725
integral	Laird	Laird NanoGreen	Folded Dipole	4.8	-	360	-	5725 - 5850
integral	Laird	Laird NanoGreen	Folded Dipole	4.8	-	360	-	5725 - 5850
external	Omni Rubber Duck	Wanshih SQ1WFI0001A	Dipole	2.0	-	360	-	5150 - 5250
external	Omni Rubber Duck	Wanshih SQ1WFI0001A	Dipole	2.0	-	360	-	5250 - 5350
external	Omni Rubber Duck	Wanshih SQ1WFI0001A	Dipole	2.0	-	360	-	5470 - 5725
external	Omni Rubber Duck	Wanshih SQ1WFI0001A	Dipole	2.0	-	360	-	5725 - 5850
external	Omni Rubber Duck	Wanshih SQ1WFI0001A	Dipole	2.0	-	360	-	5725 - 5850

BF Gain - Beamforming Gain
 Dir BW - Directional BeamWidth
 X-Pol - Cross Polarization

This test report may be reproduced in full only. The document may only be updated by MiCOM Labs personnel. Any changes will be noted in the Document History section of the report.



Title: NetScout Systems Inc. SENSOR4 Product Family
To: FCC 47 CFR Part 15.407 & IC RSS-247
Serial #: NTCT77-U3 Rev A
Issue Date: 12th December 2016
Page: 22 of 269

3.5. Cabling and I/O Ports

1	DB9	RS-232 serial console port
2	RJ-45	Ethernet + PoE
3	dc jack	12Vdc power in
4	reset	reset push button
5	RP-TNC	Reverse polarity - TNC RF antenna connector

This test report may be reproduced in full only. The document may only be updated by MiCOM Labs personnel. Any changes will be noted in the Document History section of the report.



3.6. Test Configurations

Testing was performed to determine the highest power level versus bit rate. The variant with the highest power was used to exercise the product.

Matrix of test configurations

Operational Mode(s) (802.11)	Variant	Data Rates with Highest Power	Frequencies (MHz)
a,n	Legacy	6 MBit/s	5180, 5200, 5240 5260, 5300, 5320
	HT-20	6.5 MCS	5500, 5580, 5700
	HT-40	13.5 MCS	5190, 5310 5270, 5230 5510, 5550, 5670

Antenna Test Configurations for Radiated Emissions and Band-Edge

The following measurements were performed on all antenna configurations identified in Section 3.4 Antenna Details.

Spurious Emission and Band-Edge Test Strategy Band 5,150 – 5,350

11a	11n HT-20	11n HT-40
BE 5150	BE 5150	BE 5150
SE 5180	SE 5180	SE 5190
SE 5200	SE 5200	
SE 5240	SE 5240	SE 5230
SE 5260	SE 5260	SE 5270
SE 5300	SE 5300	
SE 5320	SE 5320	SE 5310
BE 5350	BE 5350	BE 5350

KEY:-

SE – Spurious Emissions

BE – Band-Edge

PK - Peak Emission

Band 5,470 – 5,725

11a	11n HT-20	11n HT-40
SE 5500	SE 5500	SE 5510
SE 5580	SE 5580	SE 5550
SE 5700	SE 5700	SE 5670
BE 5460	BE 5460	BE 5460

This test report may be reproduced in full only. The document may only be updated by MiCOM Labs personnel. Any changes will be noted in the Document History section of the report.



Title: NetScout Systems Inc. SENSOR4 Product Family
To: FCC 47 CFR Part 15.407 & IC RSS-247
Serial #: NTCT77-U3 Rev A
Issue Date: 12th December 2016
Page: 24 of 269

3.7. Equipment Modifications

The following modifications were required to bring the equipment into compliance:

1. Output Power Settings

The output power values reported in section 5.1.2 Peak Output Power take into account any power reduction due to radiated spurious emissions and radiated band-edge measurement results.

2. Spurious Emissions V's Antenna Installation Positioning

It was found that the positioning of the external antennas was crucial in the reduction and control of spurious emissions. The device antennas were tested per the following client supplied document. Any deviation from this installation will result in non-compliant operation.

This test report may be reproduced in full only. The document may only be updated by MiCOM Labs personnel. Any changes will be noted in the Document History section of the report.

NetScout Systems Inc Sensor4 External Antenna Model Installation instructions

1. Screw on the supplied antennas to the RP-TNC connectors on the sensor side plates.
2. Position the antenna angles as shown in Figures 1 thru 5.
3. Hand tighten the antenna to the sensor while maintaining the angles depicted.
4. Apply a small amount of Loctite or similar adhesive in the antenna joint (elbow) to maintain antenna angle positioning during and after sensor installation.

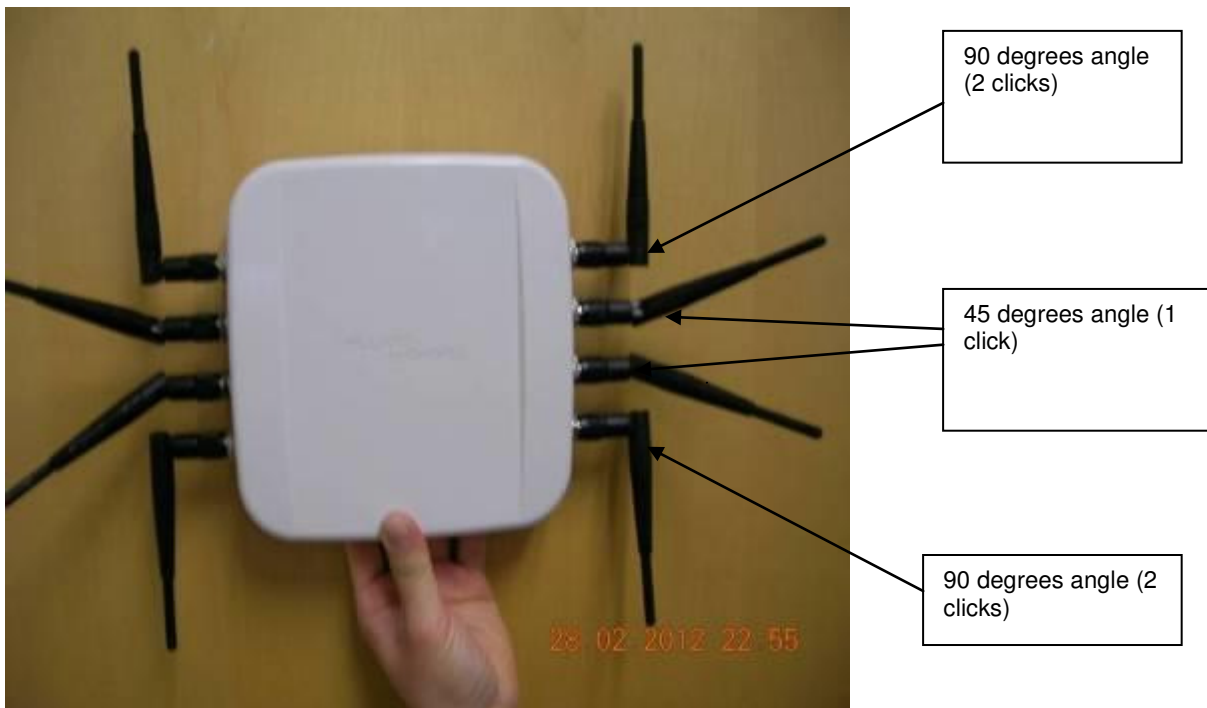

Figure 1: Top view



Figure 2: Front View

This test report may be reproduced in full only. The document may only be updated by MiCOM Labs personnel. Any changes will be noted in the Document History section of the report.



Figure 3: Diagonal view



This test report may be reproduced in full only. The document may only be updated by MiCOM Labs personnel. Any changes will be noted in the Document History section of the report.

Figure 4: Side view left.



90 degrees angle
between the 2
antennas

Figure 5: Side view right

3.8. Deviations from the Test Standard

The following deviations from the test standard were required in order to complete the test program:

1. NONE

3.9. Subcontracted Testing or Third Party Data

1. NONE



Title: NetScout Systems Inc. SENSOR4 Product Family
To: FCC 47 CFR Part 15.407 & IC RSS-247
Serial #: NTCT77-U3 Rev A
Issue Date: 12th December 2016
Page: 28 of 269

4. TEST SUMMARY

List of Measurements

The following table represents the list of measurements required under the **FCC CFR47 Part 15.407** and **Industry Canada RSS-247** and **Industry Canada ICES-003**.

Section(s)	Test Items	Description	Condition	Result	Test Report Section
15.407(a) 6.2	26dB and 99% Emission BW	Emission bandwidth measurement	Conducted	Complies	5.1.1
15.407(a) 6.2	Transmit Output Power	Power Measurement	Conducted	Complies	5.1.2
15.407(a) 6.2	Peak Power Spectral Density	PPSD	Conducted	Complies	5.1.3
15.407(g) 15.31	Frequency Stability	Limits: contained within band of operation at all times.	Applicant declaration	Complies	5.1.4
15.407(b) 15.205(a) 15.209(a) 5.2 6.2	Radiated Emissions		Radiated	Complies	5.1.5
15.407(b)(6) 15.207 6.1	AC Wireline Conducted Emissions 150 kHz–30 MHz	Conducted Emissions	Conducted	Complies	5.1.6
15.407(h) 6.3	DFS	Dynamic Frequency Selection	Conducted	Complies	5.2

This test report may be reproduced in full only. The document may only be updated by MiCOM Labs personnel. Any changes will be noted in the Document History section of the report.



Title: NetScout Systems Inc. SENSOR4 Product Family
To: FCC 47 CFR Part 15.407 & IC RSS-247
Serial #: NTCT77-U3 Rev A
Issue Date: 12th December 2016
Page: 29 of 269

Note 1: Test results reported in this document relate only to the items tested

Note 2: The required tests demonstrated compliance as per client declaration of test configuration, monitoring methodology and associated pass/fail criteria

Note 3: Section 3.7 Equipment Modifications highlights the equipment modifications that were required to bring the product into compliance with the above test matrix

This test report may be reproduced in full only. The document may only be updated by MiCOM Labs personnel. Any changes will be noted in the Document History section of the report.

1. TEST EQUIPMENT CONFIGURATION(S)

1.1. Radiated Emissions - 3m Chamber

The following tests were performed using the radiated test set-up shown in the diagram below. Radiated emissions below 1GHz.; and Radiated Emissions above 1GHz.

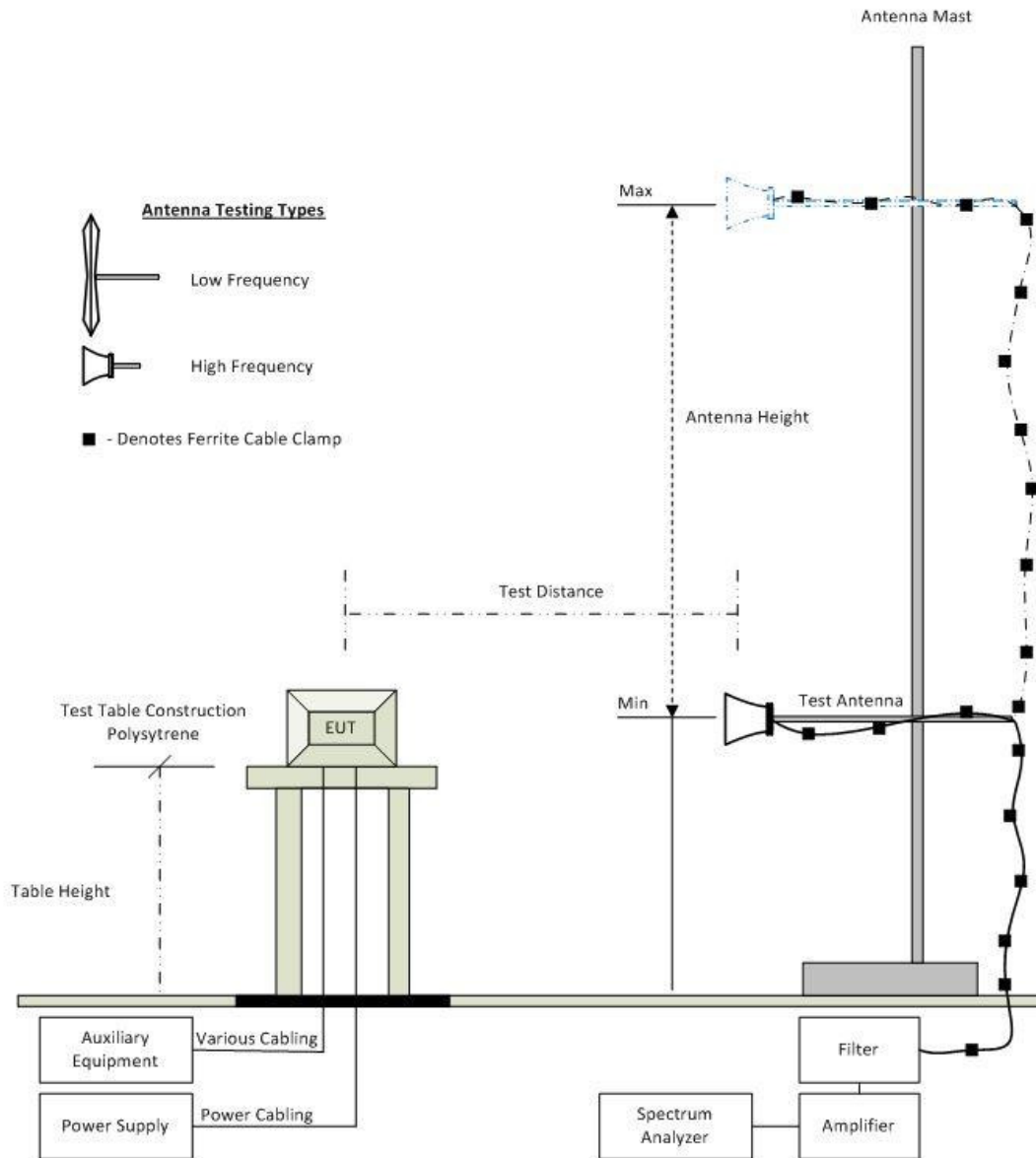

Radiated Emission Test Setup

A full system calibration was performed on the test station and any resulting system losses (or gains) were taken into account in the production of all final measurement data.

This test report may be reproduced in full only. The document may only be updated by MiCOM Labs personnel. Any changes will be noted in the Document History section of the report.



Title: NetScout Systems Inc. SENSOR4 Product Family
To: FCC 47 CFR Part 15.407 & IC RSS-247
Serial #: NTCT77-U3 Rev A
Issue Date: 12th December 2016
Page: 31 of 269

Asset#	Description	Manufacturer	Model#	Serial#	Calibration Due Date
158	Barometer/Thermometer	Control Company	4196	E2846	30 Nov 2017
170	Video System Controller for Semi Anechoic Chamber	Panasonic	WV-CU101	04R08507	Not Required
287	Rohde & Schwarz 40 GHz Receiver	Rhode & Schwarz	ESIB40	100201	02 May 2017
301	5470 to 5725 MHz Notch Filter	Microtronics	RBC50704	001	16 Aug 2017
302	5150 to 5350 MHz Notch Filter	Microtronics	BRC50703	002	16 Aug 2017
303	5725 to 5875 MHz Notch filter	Microtronics	BRC50705	003	16 Aug 2017
330	Variac 0-280 Vac	Staco Energy Co	3PN1020B	0546	Cal when used
336	Active loop Ant 10kHz to 30 MHz	EMCO	EMCO 6502	00060498	26 Sep 2017
338	Sunol 30 to 3000 MHz Antenna	Sunol	JB3	A052907	15 Aug 2017
373	26III RMS Multimeter	Fluke	Fluke 26 series III	76080720	26 Oct 2017
377	Band Rejection Filter 5150 to 5880MHz	Microtronics	BRM50716	034	16 Aug 2017
378	Rohde & Schwarz 40 GHz Receiver with Generator	Rhode & Schwarz	ESIB40	100107/040	04 Aug 2017
393	DC - 1050 MHz Low Pass Filter	Microcircuits	VLFX-1050	N/A	16 Aug 2017
396	2.4 GHz Notch Filter	Microtronics	BRM50701	001	16 Aug 2017
397	Amp 10 - 2500MHz	MiCOM Labs	Amp 10 - 2500 MHz	NA	09 Jun 2017
399	ETS 1-18 GHz Horn Antenna	ETS	3117	00154575	10 Jan 2017
406	Amplifier for Radiated Emissions	MiCOM Labs	40dB 1 to 18GHz Amp	0406	09 Jun 2017
410	Desktop Computer	Dell	Inspiron 620	WS38	Not Required
411	Mast/Turntable Controller	Sunol Sciences	SC98V	060199-1D	Not Required
412	USB to GPIB Interface	National Instruments	GPIB-USB HS	11B8DC2	Not Required
413	Mast Controller	Sunol Science	TWR95-4	030801-3	Not Required
414	DC Power Supply 0-60V	HP	6274	1029A01285	Cal when used
415	Turntable Controller	Sunol Sciences	Turntable Controller	None	Not Required
416	Gigabit ethernet filter	ETS-Lingren	Gigafoil 260366	None	Not Required
447	Rad Emissions Test Software	MiCOM	Rad Emissions Test Software Version	447	Not Required

This test report may be reproduced in full only. The document may only be updated by MiCOM Labs personnel. Any changes will be noted in the Document History section of the report.



Title: NetScout Systems Inc. SENSOR4 Product Family
To: FCC 47 CFR Part 15.407 & IC RSS-247
Serial #: NTCT77-U3 Rev A
Issue Date: 12th December 2016
Page: 32 of 269

			1.0.109		
462	Schwarzbeck cable from Antenna to Amplifier.	Schwarzbeck	AK 9513	462	31 May 2017
463	Schwarzbeck cable from Amplifier to Bulkhead.	Schwarzbeck	AK 9513	463	31 May 2017
464	Schwarzbeck cable from Bulkhead to Receiver	Schwarzbeck	AK 9513	464	31 May 2017
465	Low Pass Filter DC-1000 MHz	Mini-Circuits	NLP-1200+	VUU01901402	02 Jun 2017
466	Low Pass Filter DC-1500 MHz	Mini-Circuits	NLP-1750+	VUU10401438	02 Jun 2017
467	2495 to 2650 MHz notch filter	MicroTronics	BRM50709	011	16 Aug 2017
468	Low pass filter	Mini Circuits	SLP-550	None	16 Aug 2017
469	Low pass filter	Mini Circuit	SLP-1000	None	16 Aug 2017
470	High Pass filter	Mini Circuits	SHP-700	None	16 Aug 2017
476	Low Pass dc-2200MHz filter	Mini Circuits	15542 NLP-2400+	VUU13801345	16 Aug 2017
480	Cable - Bulkhead to Amp	SRC Haverhill	157-157-3050360	480	02 Jun 2017
481	Cable - Bulkhead to Receiver	SRC Haverhill	151-151-3050787	481	02 Jun 2017
482	Cable - Amp to Antenna	SRC Haverhill	157-157-3051574	482	02 Jun 2017
502	Test Software for Radiated Emissions	EMISoft	Vasona	Version 5 Build 59	Not Required
87	Uninterruptible Power Supply	Falcon Electric	ED2000-1/2LC	F3471 02/01	Cal when used
VLF-1700	Low pass filter DC-1700 MHz	Mini Circuits	VLF-1700	None	31 May 2017

This test report may be reproduced in full only. The document may only be updated by MiCOM Labs personnel. Any changes will be noted in the Document History section of the report.

1.2. Conducted

Conducted RF Emission Test Set-up(s)

The following tests were performed using the conducted test set-up shown in the diagram below.

1. PEAK TRANSMIT POWER
2. 6 dB & 99% BANDWIDTH
3. POWER SPECTRAL DENSITY

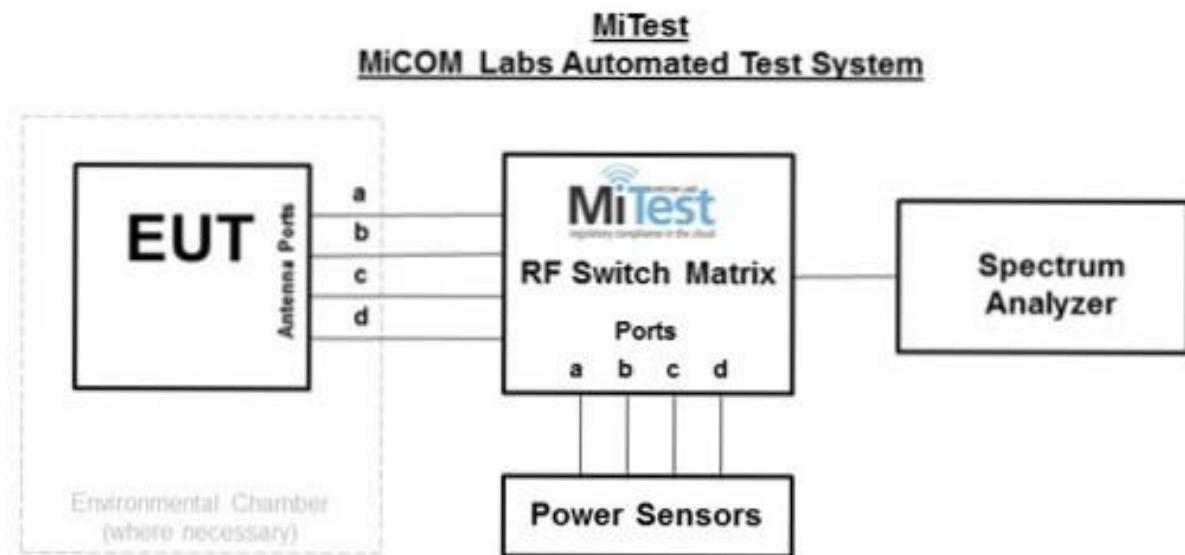

A full system calibration was performed on the test station and any resulting system losses (or gains) were taken into account in the production of all final measurement data.

Asset#	Description	Manufacturer	Model#	Serial#	Calibration Due Date
127	Power Supply	HP	6674A	US36370530	Cal when used
158	Barometer/Thermometer	Control Company	4196	E2846	30 Nov 2017
248	Resistance Thermometer	Thermotronics	GR2105-02	9340 #1	21 Oct 2017
287	Rohde & Schwarz 40 GHz Receiver	Rhode & Schwarz	ESIB40	100201	02 May 2017
376	USB 10MHz - 18GHz Average Power Sensor	Agilent	U2000A	MY51440005	23 Oct 2017
378	Rohde & Schwarz 40 GHz Receiver with Generator	Rhode & Schwarz	ESIB40	100107/040	04 Aug 2017
381	4x4 RF Switch Box	MiCOM Labs	MiTest RF	MIC002	18 Dec 2016

This test report may be reproduced in full only. The document may only be updated by MiCOM Labs personnel. Any changes will be noted in the Document History section of the report.



Title: NetScout Systems Inc. SENSOR4 Product Family
To: FCC 47 CFR Part 15.407 & IC RSS-247
Serial #: NTCT77-U3 Rev A
Issue Date: 12th December 2016
Page: 34 of 269

			Switch Box		
398	Test Software	MiCOM	MiTest ATS	Version 4.1.0.76	Not Required
419	Laptop with Labview Software	Lenova	W520	TS02	Not Required
420	USB to GPIB Interface	National Instruments	GPIB-USB HS	1346738	Not Required
440	USB Wideband Power Sensor	Boonton	55006	9178	25 Dec 2016
442	USB Wideband Power Sensor	Boonton	55006	9181	06 Oct 2017
445	PoE Injector	D-Link	DPE-101GL	QTAH1E2000625	Not Required
460	Dell Computer with installation of MiTest executable.	Dell	Optiplex330	BC944G1	Not Required
461	Spectrum Analyzer	Agilent	E4440A	MY46185537	13 Aug 2017
493	USB Wideband Power Sensor	Boonton	55006	9634	10 Mar 2017
494	USB Wideband Power Sensor	Boonton	55006	9726	10 Mar 2017
74	Environmental Chamber Chamber 3	Tenney	TTC	12808-1	29 Sep 2017
RF#2 GPIB#1	GPIB cable to Power Supply	HP	GPIB	None	Not Required
RF#2 SMA#1	EUT to Mitest box port 1	Flexco	SMA Cable port1	None	18 Dec 2016
RF#2 SMA#2	EUT to Mitest box port 2	Flexco	SMA Cable port2	None	18 Dec 2016
RF#2 SMA#3	EUT to Mitest box port 3	Flexco	SMA Cable port3	None	18 Dec 2016
RF#2 SMA#4	EUT to Mitest box port 4	Flexco	SMA Cable port4	None	18 Dec 2016
RF#2 SMA#SA	Mitest box to SA	Flexco	SMA Cable SA	None	18 Dec 2016
RF#2 USB#1	USB Cable to Mitest Box	Dynex	USB Cable	None	Not Required

This test report may be reproduced in full only. The document may only be updated by MiCOM Labs personnel. Any changes will be noted in the Document History section of the report.

1.3. DFS - Conducted

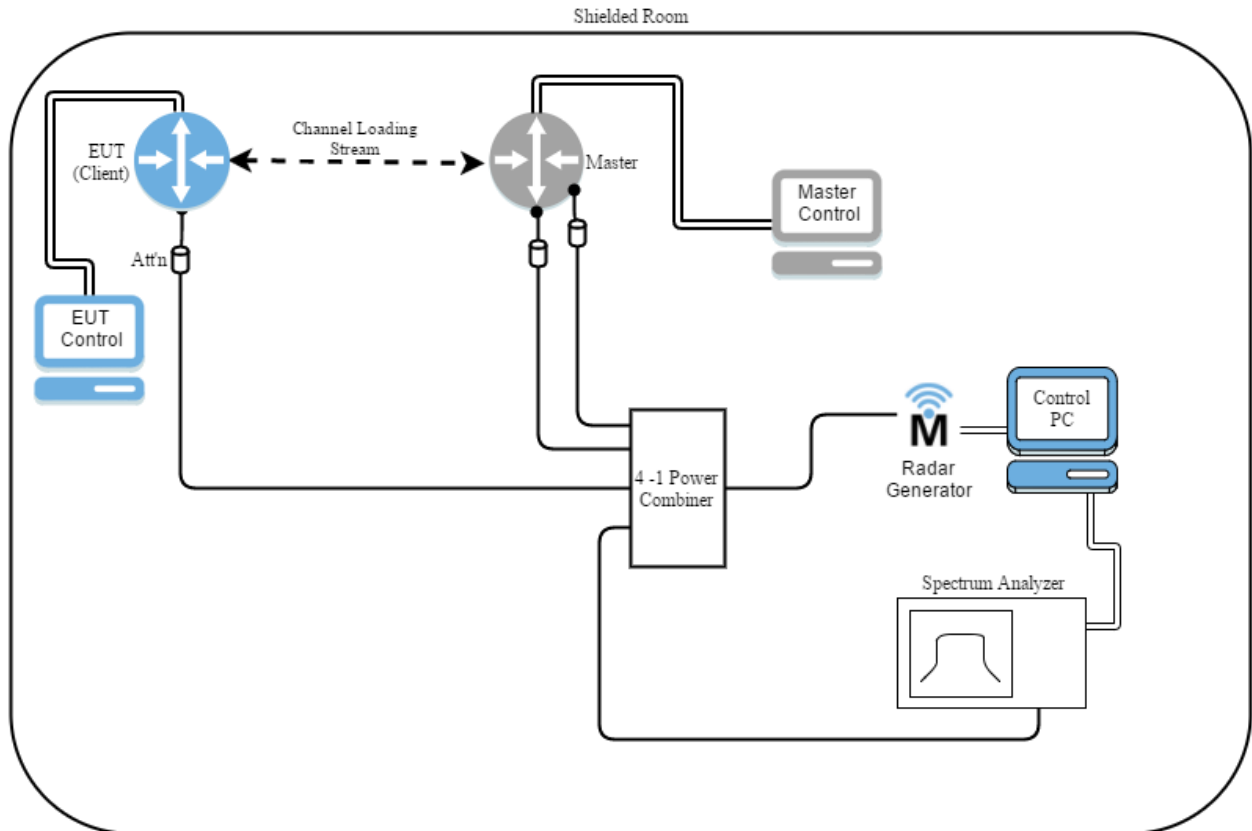

A full system calibration was performed on the test station and any resulting system losses (or gains) were taken into account in the production of all final measurement data.



Title: NetScout Systems Inc. SENSOR4 Product Family
To: FCC 47 CFR Part 15.407 & IC RSS-247
Serial #: NTCT77-U3 Rev A
Issue Date: 12th December 2016
Page: 36 of 269

Asset#	Description	Manufacturer	Model#	Serial#	Calibration Due Date
158	Barometer/Thermometer	Control Company	4196	E2846	30 Nov 2017
193	Receiver 20 Hz to 7 GHz	Rhode & Schwarz	ESI 7	838496/007	17 May 2017
299	Test Software DFS Test System	Aeroflex	DFS test Software	V2.7.0	Not Required
359	DFS System	Aeroflex	PXI-1042	300001/004	18 Jun 2016
417	Laptop for DFS with DFS software	Lenova	W520	DFS	Not Required
418	PCI-e interface card	National Instruments	Express 8360	174AAC5	Not Required
422	Splitter/Combiner	Pasternack	PE 2031	001	Cal when used
71	Spectrum Analyser 9KHz-50GHz	HP	8565E	3425A00181	06 Aug 2017
DFS PCIe#1	PCIe cable for Aeroflex	National Instruments	PCIe cable	None	Not Required
DFS SMA#1	SMA Cable for DFS	Megaphase	SMA Cable	None	Cal when used
DFS SMA#2	SMA Cable for DFS	Megaphase	SMA Cable	None	Cal when used
DFS SMA#3	SMA Cable for DFS	Megaphase	SMA Cable	None	Cal when used
DFS SMA#4	SMA Cable for DFS	Megaphase	SMA Cable	None	Cal when used

This test report may be reproduced in full only. The document may only be updated by MiCOM Labs personnel. Any changes will be noted in the Document History section of the report.

5. TEST RESULTS

5.1. Device Characteristics

5.1.1. 26 dB and 99 % Bandwidth

FCC, Part 15 Subpart C §15.407(a)
Industry Canada RSS-247 § 6.2

Test Procedure

The bandwidth at 26 dB and 99 % is measured with a spectrum analyzer connected to the antenna terminal, while EUT is operating in transmission mode at the appropriate center frequency.

Test Measurement Set up

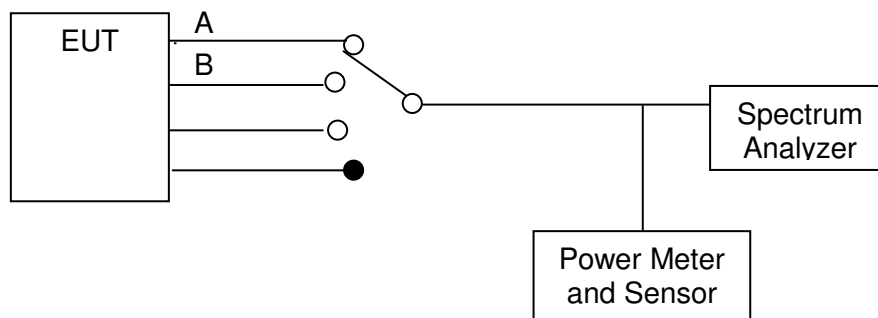

Measurement set up for 26 dB and 99 % bandwidth test

Radio Parameters

Duty Cycle: 100%

Output: Modulated Carrier

Power: Maximum Default Power



Title: NetScout Systems Inc. SENSOR4 Product Family
To: FCC 47 CFR Part 15.407 & IC RSS-247
Serial #: NTCT77-U3 Rev A
Issue Date: 12th December 2016
Page: 38 of 269

Measurement Results for 26 dB and 99 % Operational Bandwidth(s)

Ambient conditions.

Temperature: 17 to 23 °C Relative humidity: 31 to 57 % Pressure: 999 to 1012 mbar

TABLE OF RESULTS – 802.11a Legacy 5150 – 5250 MHz

Test Conditions:	15.247 (a)(2)	Rel. Humidity (%):	35 to 42
Variant:	802.11a	Ambient Temp. (°C):	19 to 22
TPC:	HIGH	Pressure (mBars):	998 to 1003
Modulation:	ON	Duty Cycle (x):	100
Beam Forming Gain (Y):	N/A dB	Antenna Gain:	0 dBi
Applied Voltage:	48.0 Vdc		
Notes 1:			
Notes 2:			

26 dB Bandwidth

Test Frequency	26 dB Bandwidth				Minimum 6dB Bandwidth Limit		Margin
	MHz				kHz	MHz	
MHz	a	b	c	d			
5180	22.445000	22.946000	23.447000		500	0.5	-21.945000
5200	22.445000	22.846000	23.146000				-21.945000
5240	22.345000	23.146000	23.347000				-21.845000

99% Bandwidth

Test Frequency	99 % Bandwidth						
	MHz						
MHz	a	b	c	d			
5180	16.733000	16.834000	16.834000				
5200	16.733000	16.733000	16.934000				
5240	16.733000	16.733000	16.834000				

Measurement uncertainty:	±2.81 dB
---------------------------------	----------

This test report may be reproduced in full only. The document may only be updated by MiCOM Labs personnel. Any changes will be noted in the Document History section of the report.



PORT A 5,180 MHz 802.11a Legacy 26 dB and 99 % Bandwidth

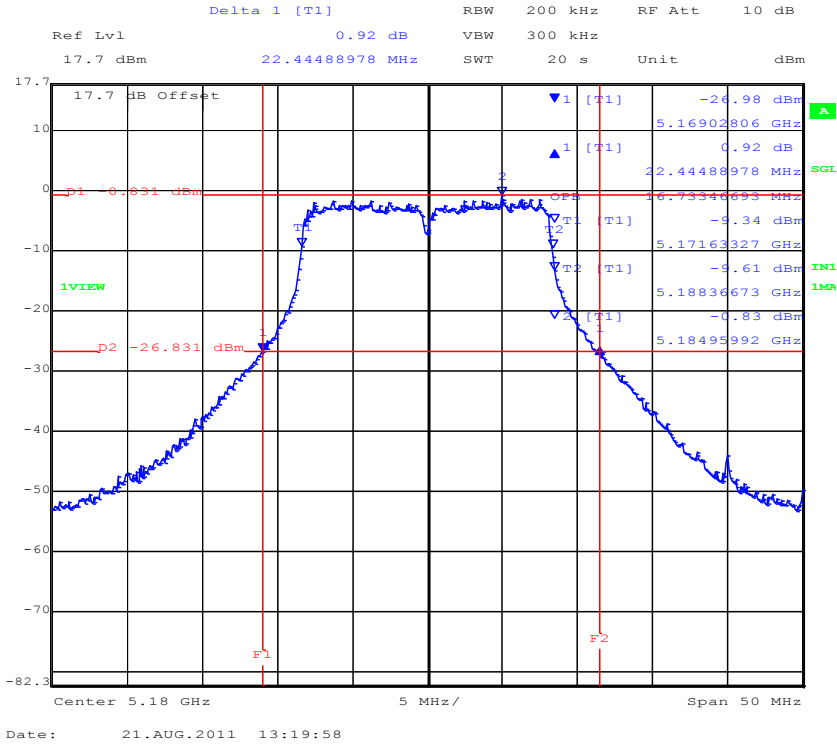

PORT B 5,180 MHz 802.11a Legacy 26 dB and 99 % Bandwidth

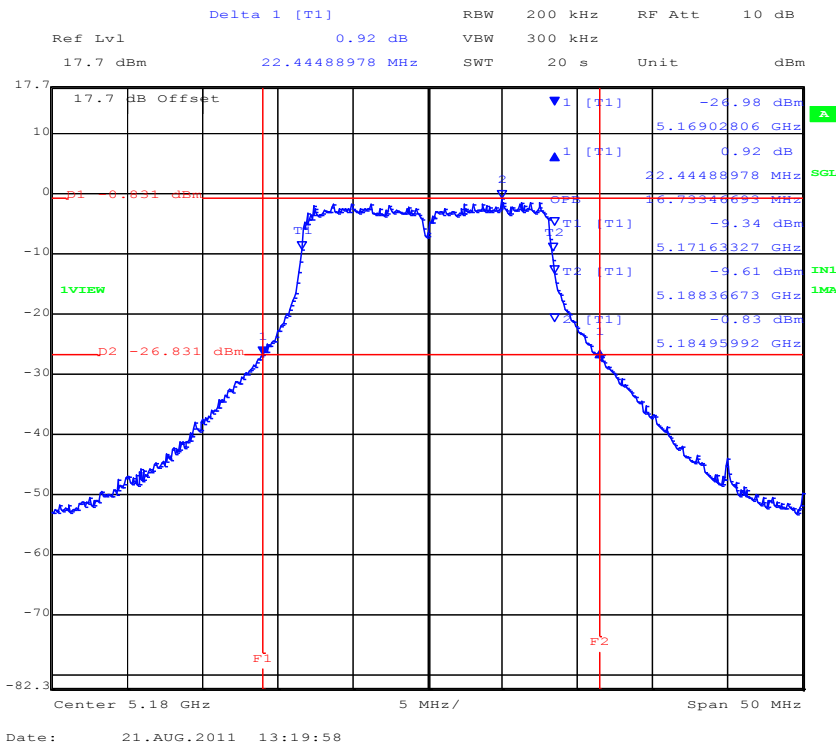

This test report may be reproduced in full only. The document may only be updated by MiCOM Labs personnel. Any changes will be noted in the Document History section of the report.



PORT C 5,180 MHz 802.11a Legacy 26 dB and 99 % Bandwidth

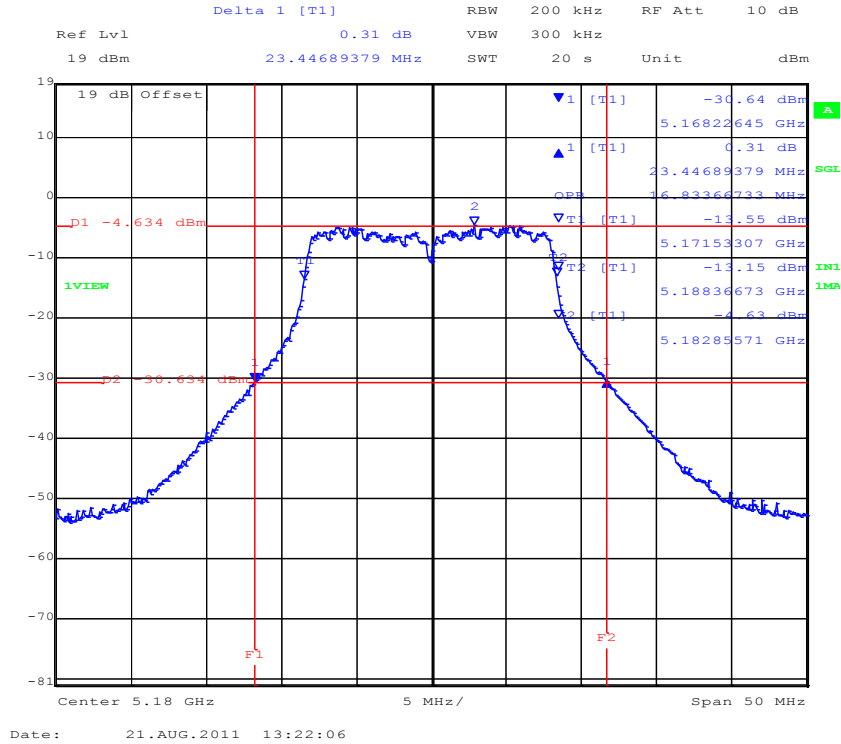

This test report may be reproduced in full only. The document may only be updated by MiCOM Labs personnel. Any changes will be noted in the Document History section of the report.



PORT A 5,200 MHz 802.11a Legacy 26 dB and 99 % Bandwidth

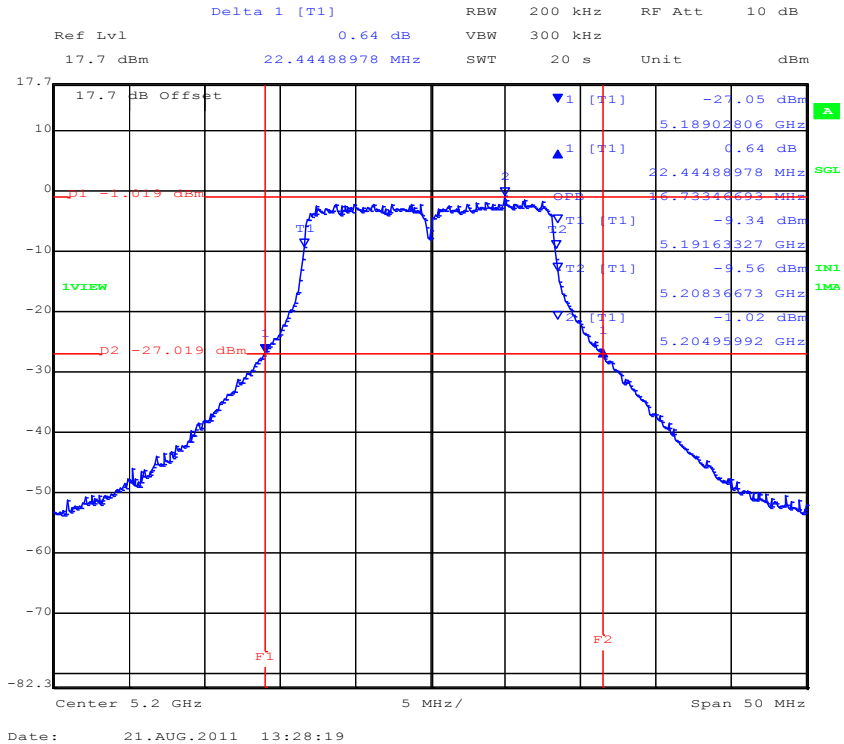

PORT B 5,200 MHz 802.11a Legacy 26 dB and 99 % Bandwidth

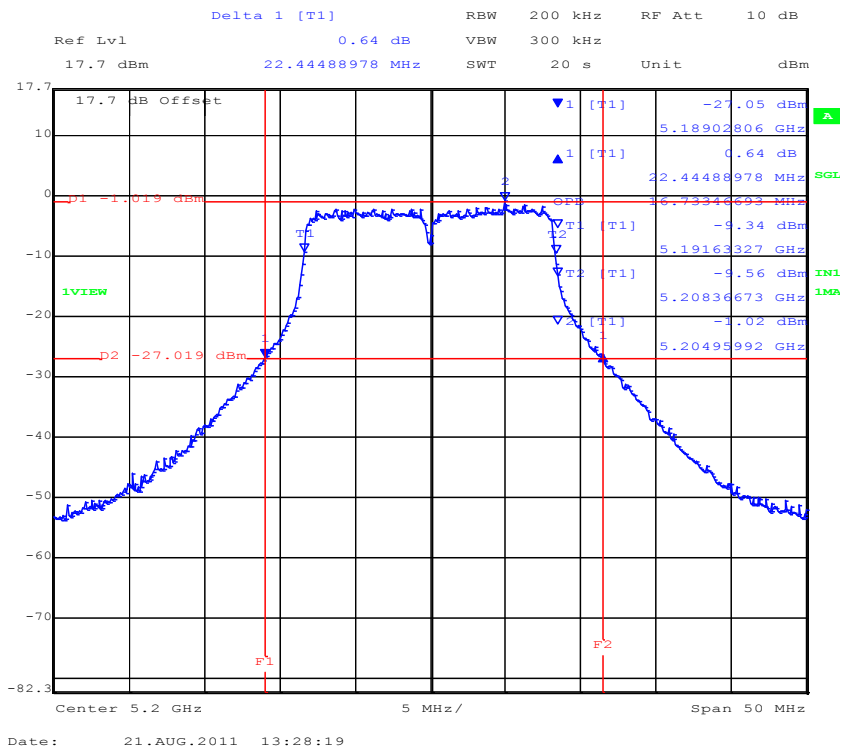

This test report may be reproduced in full only. The document may only be updated by MiCOM Labs personnel. Any changes will be noted in the Document History section of the report.



PORT C 5,200 MHz 802.11a Legacy 26 dB and 99 % Bandwidth

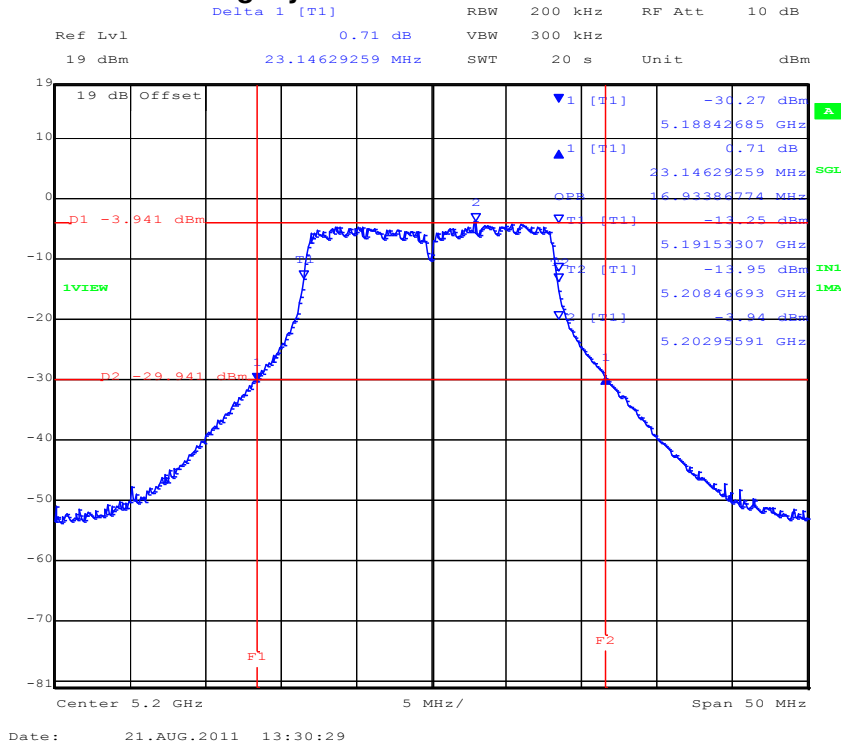

This test report may be reproduced in full only. The document may only be updated by MiCOM Labs personnel. Any changes will be noted in the Document History section of the report.



PORT A 5,240 MHz 802.11a Legacy 26 dB and 99 % Bandwidth

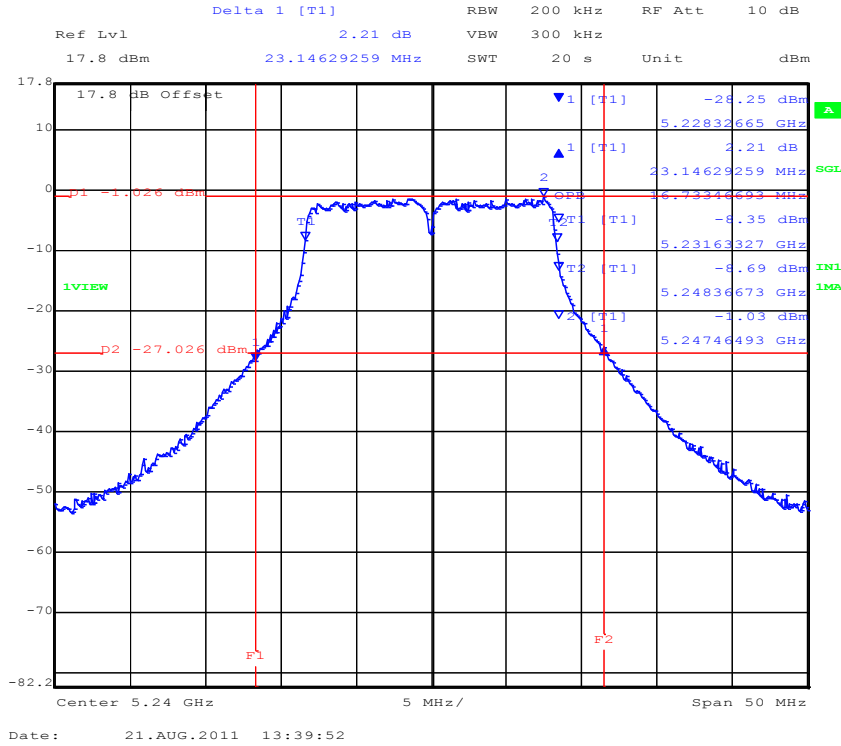

PORT B 5,240 MHz 802.11a Legacy 26 dB and 99 % Bandwidth

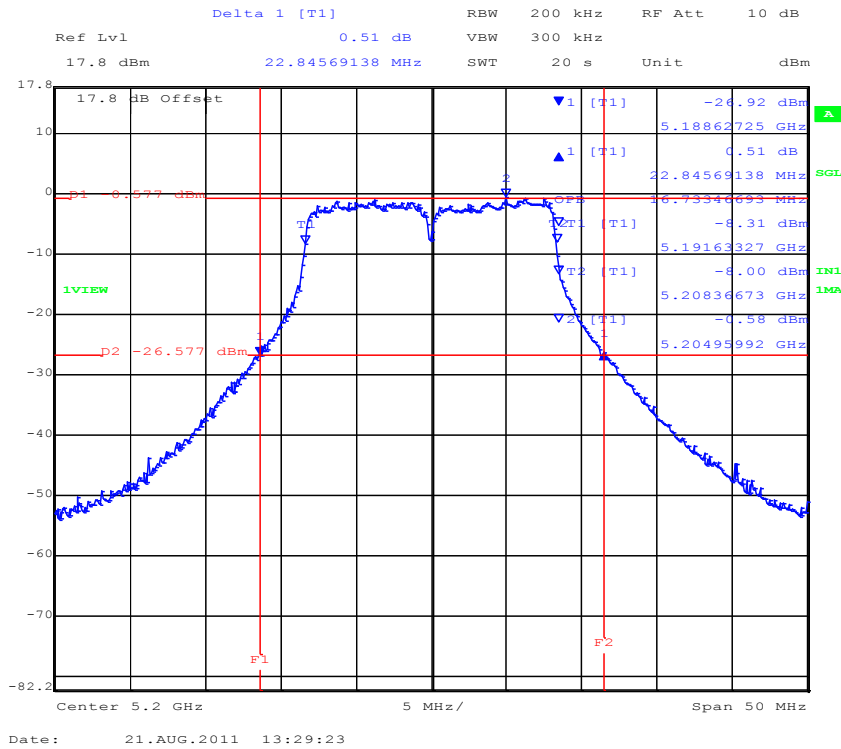

This test report may be reproduced in full only. The document may only be updated by MiCOM Labs personnel. Any changes will be noted in the Document History section of the report.



PORT C 5,240 MHz 802.11a Legacy 26 dB and 99 % Bandwidth

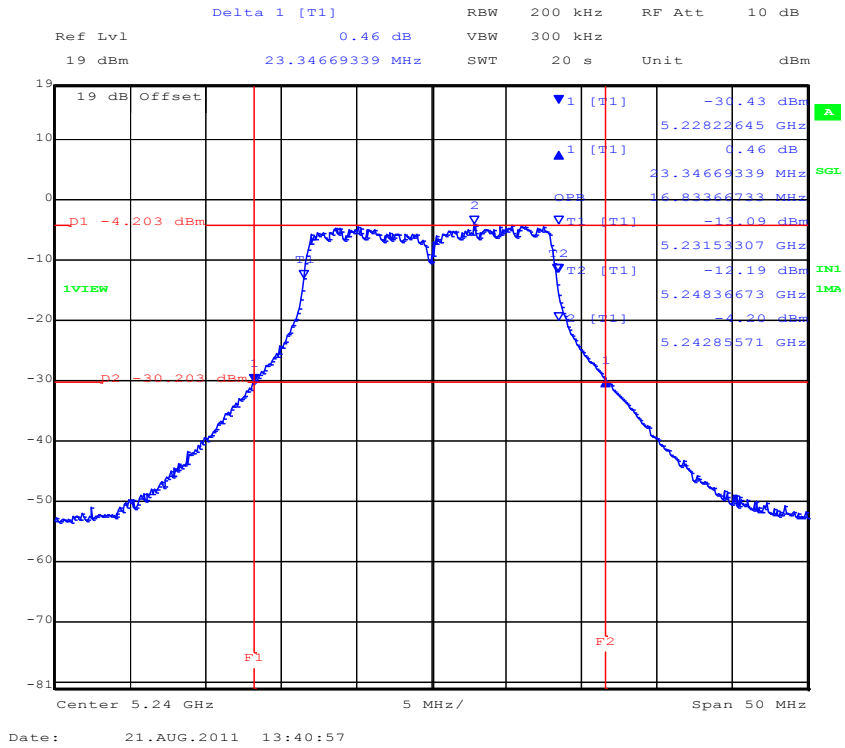

This test report may be reproduced in full only. The document may only be updated by MiCOM Labs personnel. Any changes will be noted in the Document History section of the report.



Title: NetScout Systems Inc. SENSOR4 Product Family
To: FCC 47 CFR Part 15.407 & IC RSS-247
Serial #: NTCT77-U3 Rev A
Issue Date: 12th December 2016
Page: 45 of 269

TABLE OF RESULTS – 802.11n HT-20 5150 – 5250 MHz

Test Conditions:	15.247 (a)(2)	Rel. Humidity (%):	35 to 42
Variant:	802.11n HT-20	Ambient Temp. (°C):	19 to 22
TPC:	HIGH	Pressure (mBars):	998 to 1003
Modulation:	ON	Duty Cycle (x):	100
Beam Forming Gain (Y):	N/A dB	Antenna Gain:	0 dBi
Applied Voltage:	48.0 Vdc		
Notes 1:			
Notes 2:			

26 dB Bandwidth

Test Frequency	26 dB Bandwidth				Minimum 6dB Bandwidth Limit		Margin
	MHz				kHz	MHz	
MHz	a	b	c	d			
5180	23.547000	23.547000	24.549000		500	0.5	-23.047000
5200	23.246000	23.547000	24.549000				-22.746000
5240	23.347000	23.347000	24.649000				-22.847000

99% Bandwidth

Test Frequency	99 % Bandwidth						
	MHz						
MHz	a	b	c	d			
5180	17.936000	17.936000	18.036000				
5200	17.936000	18.036000	18.036000				
5240	17.936000	17.936000	18.036000				

Measurement uncertainty:	±2.81 dB
---------------------------------	----------

This test report may be reproduced in full only. The document may only be updated by MiCOM Labs personnel. Any changes will be noted in the Document History section of the report.



PORT A 5,180 MHz 802.11n HT-20 26 dB and 99 % Bandwidth

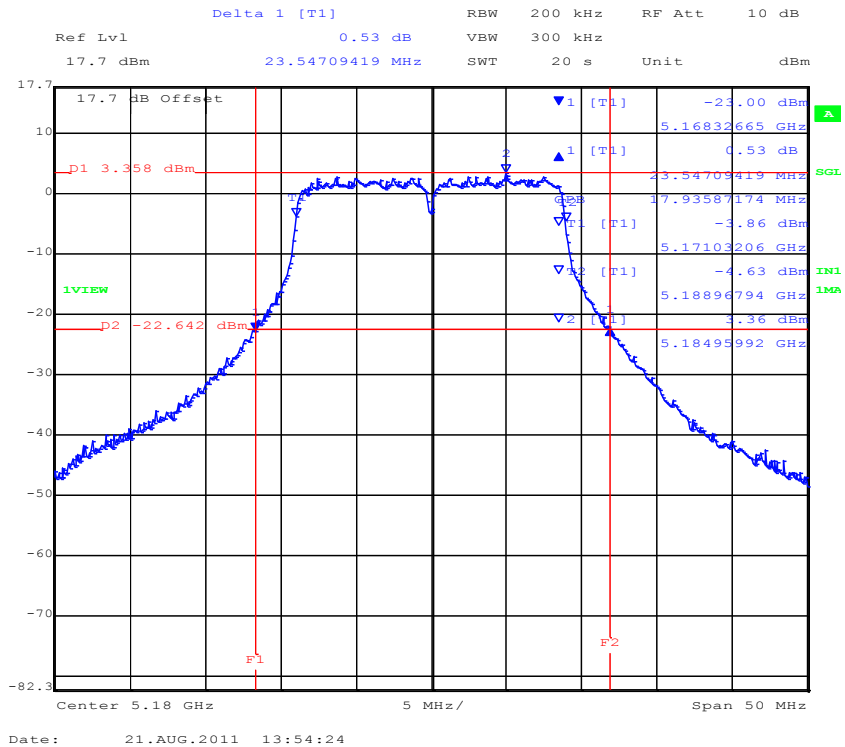

PORT B 5,180 MHz 802.11a Legacy 26 dB and 99 % Bandwidth

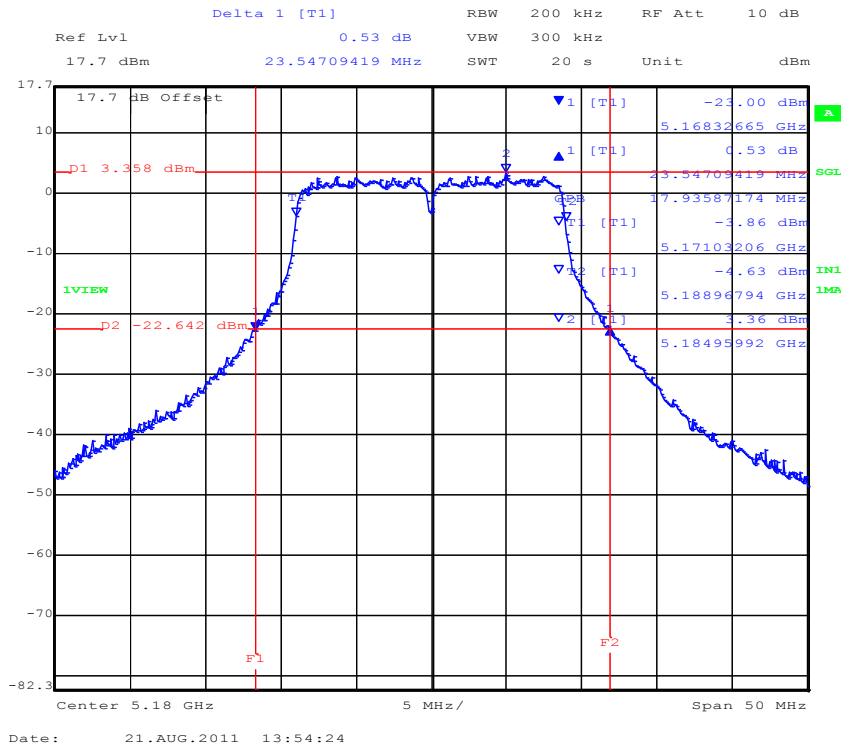

This test report may be reproduced in full only. The document may only be updated by MiCOM Labs personnel. Any changes will be noted in the Document History section of the report.



PORT C 5,180 MHz 802.11a Legacy 26 dB and 99 % Bandwidth

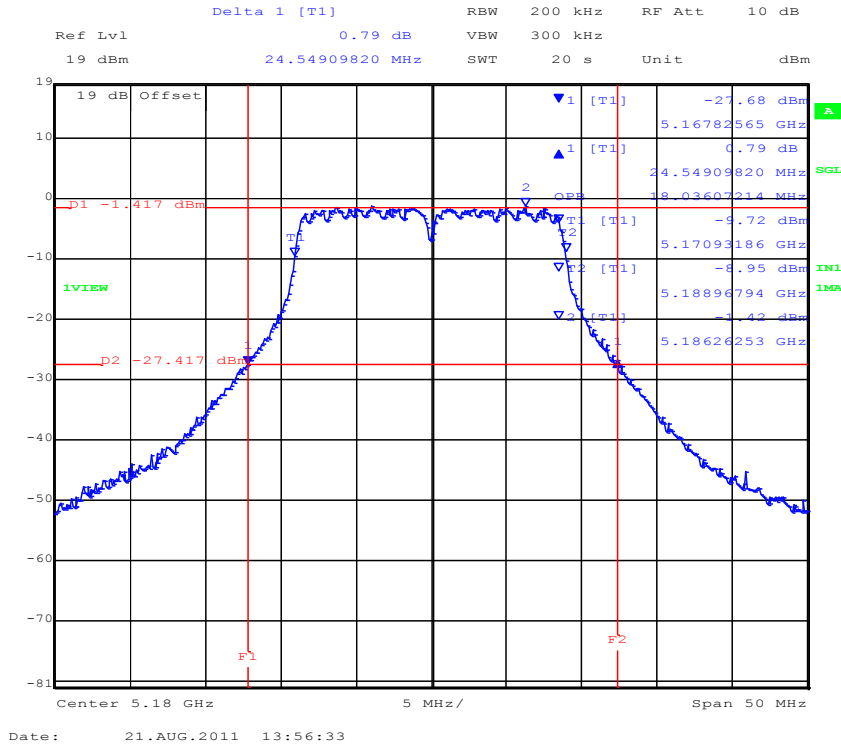

This test report may be reproduced in full only. The document may only be updated by MiCOM Labs personnel. Any changes will be noted in the Document History section of the report.



Title: NetScout Systems Inc. SENSOR4 Product Family
To: FCC 47 CFR Part 15.407 & IC RSS-247
Serial #: NTCT77-U3 Rev A
Issue Date: 12th December 2016
Page: 48 of 269

PORT A 5,200 MHz 802.11n HT-20 26 dB and 99 % Bandwidth

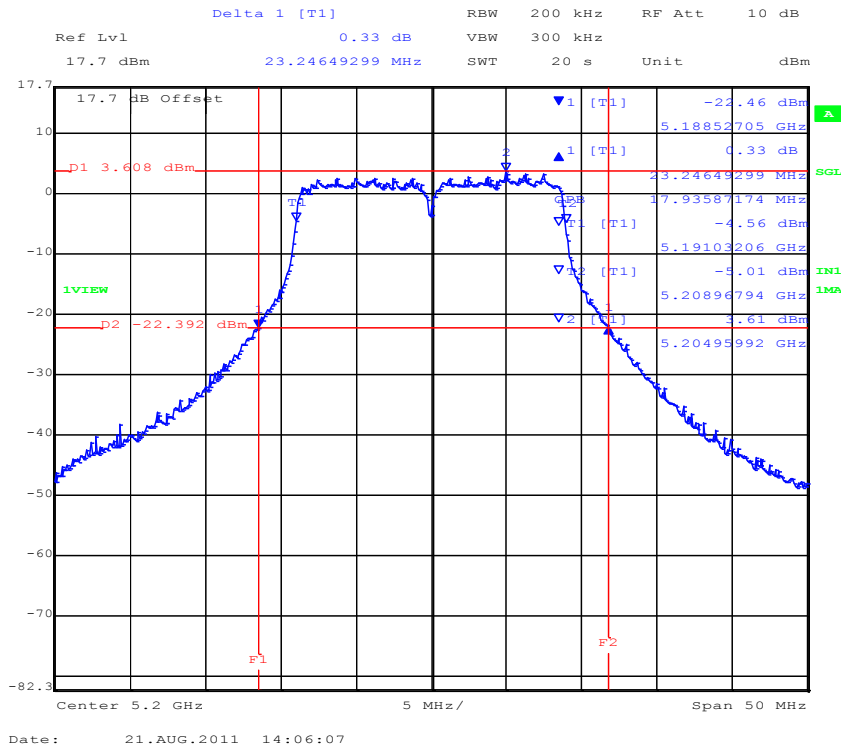

PORT B 5,200 MHz 802.11a Legacy 26 dB and 99 % Bandwidth

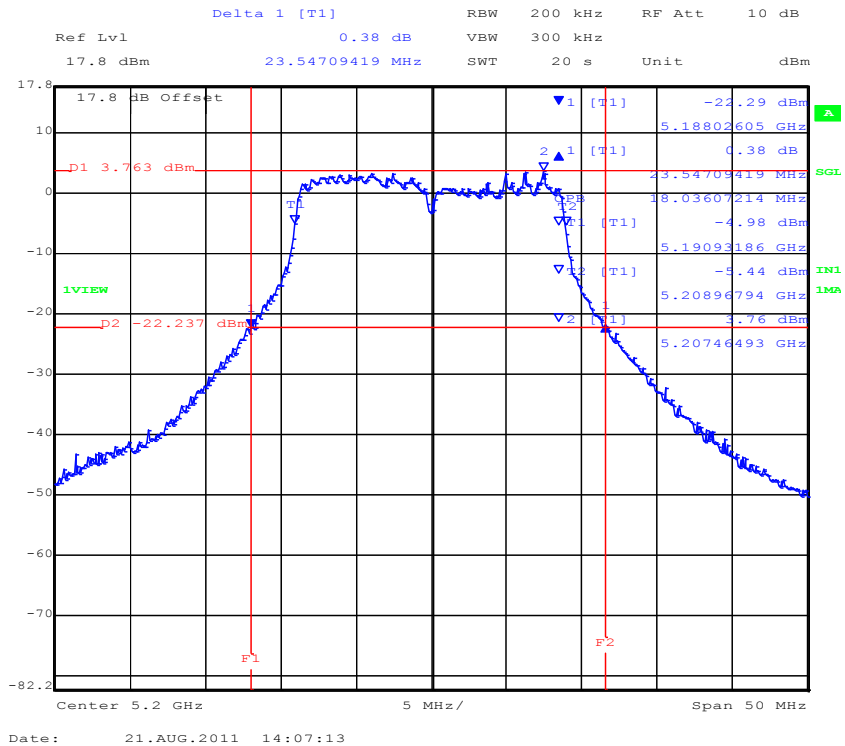

This test report may be reproduced in full only. The document may only be updated by MiCOM Labs personnel. Any changes will be noted in the Document History section of the report.



Title: NetScout Systems Inc. SENSOR4 Product Family
To: FCC 47 CFR Part 15.407 & IC RSS-247
Serial #: NTCT77-U3 Rev A
Issue Date: 12th December 2016
Page: 49 of 269

PORT C 5,200 MHz 802.11a Legacy 26 dB and 99 % Bandwidth

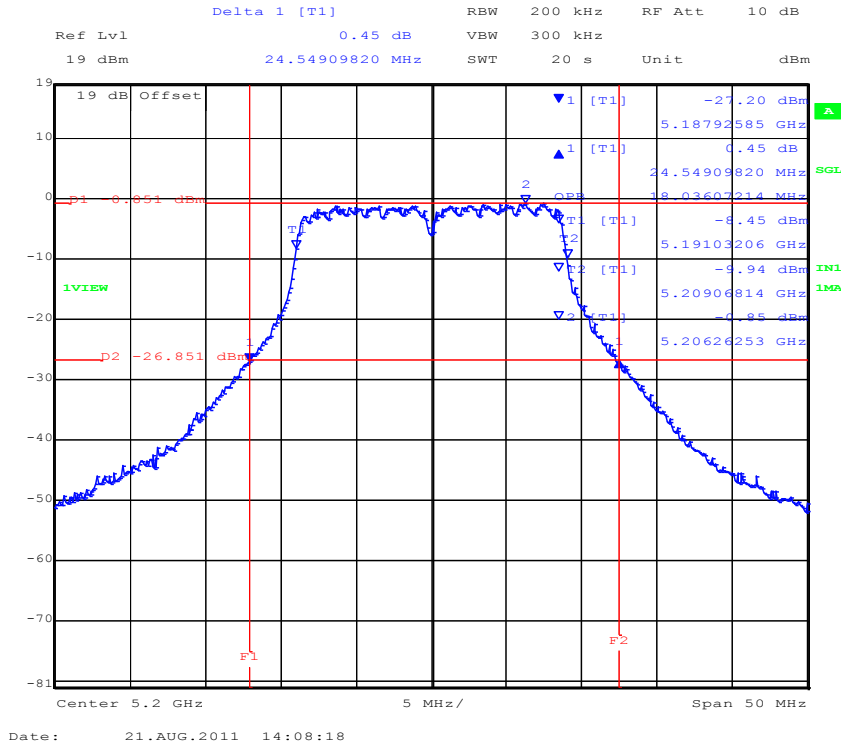

This test report may be reproduced in full only. The document may only be updated by MiCOM Labs personnel. Any changes will be noted in the Document History section of the report.



PORT A 5,240 MHz 802.11n HT-20 26 dB and 99 % Bandwidth

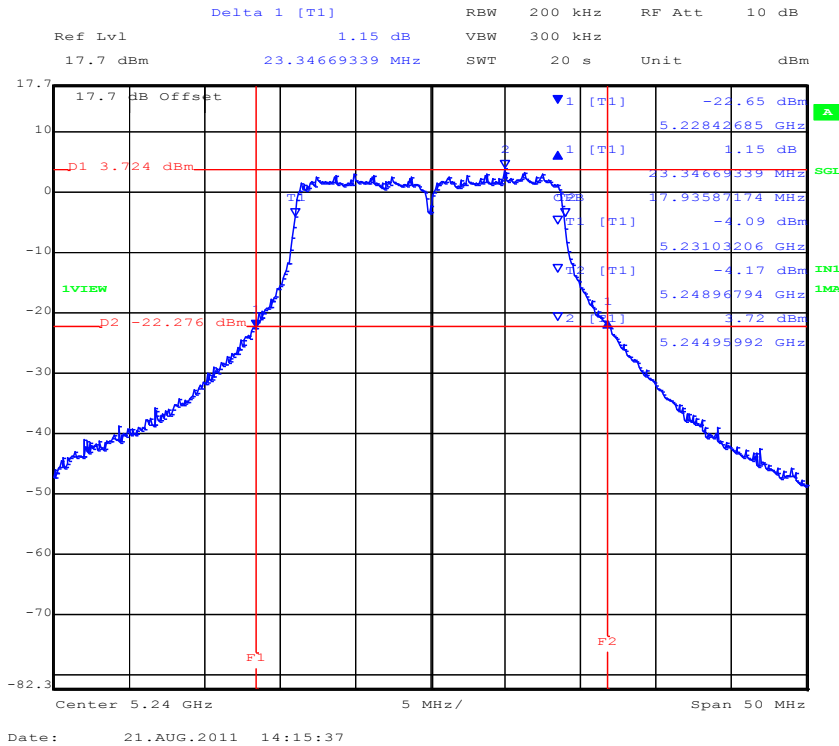

PORT B 5,240 MHz 802.11a Legacy 26 dB and 99 % Bandwidth

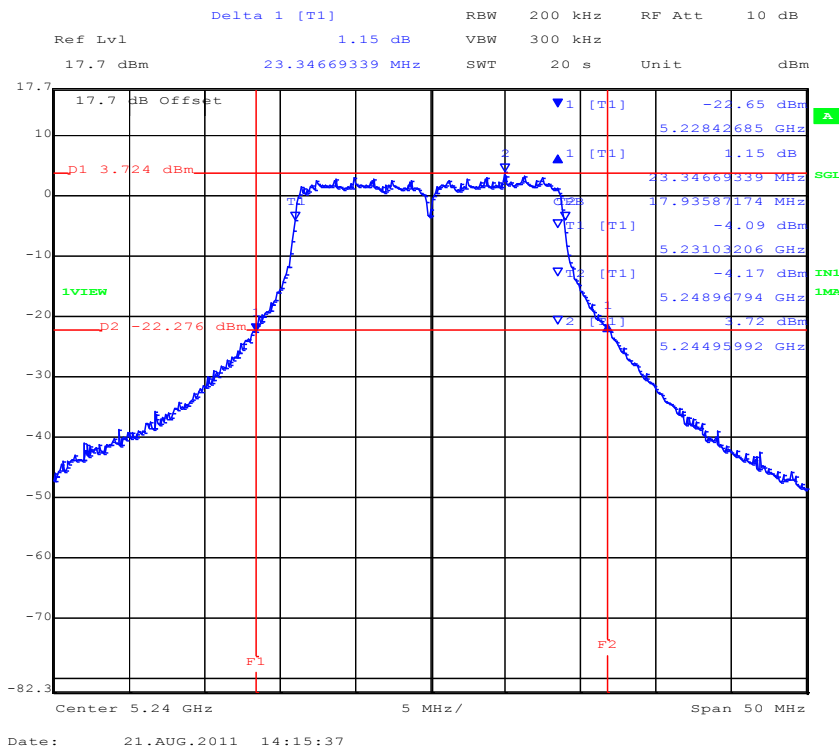

This test report may be reproduced in full only. The document may only be updated by MiCOM Labs personnel. Any changes will be noted in the Document History section of the report.



PORT C 5,240 MHz 802.11a Legacy 26 dB and 99 % Bandwidth

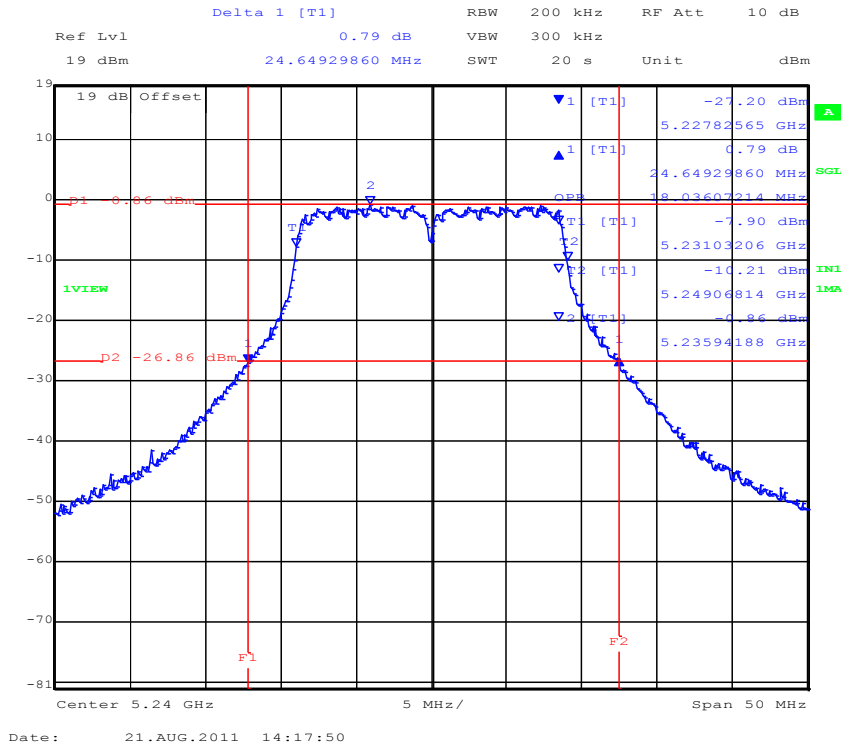

This test report may be reproduced in full only. The document may only be updated by MiCOM Labs personnel. Any changes will be noted in the Document History section of the report.



Title: NetScout Systems Inc. SENSOR4 Product Family
To: FCC 47 CFR Part 15.407 & IC RSS-247
Serial #: NTCT77-U3 Rev A
Issue Date: 12th December 2016
Page: 52 of 269

TABLE OF RESULTS – 802.11n HT-40 5150 – 5250 MHz

Test Conditions:	15.247 (a)(1)	Rel. Humidity (%):	35 to 42
Variant:	802.11n HT-40	Ambient Temp. (°C):	19 to 22
TPC:	HIGH	Pressure (mBars):	998 to 1003
Modulation:	ON	Duty Cycle (x):	100
Beam Forming Gain (Y):	N/A dB	Antenna Gain:	0 dBi
Applied Voltage:	48.0 Vdc		
Notes 1:			
Notes 2:			

26 dB Bandwidth

Test Frequency	26 dB Bandwidth				Minimum 6dB Bandwidth Limit		Margin
	MHz				kHz	MHz	
MHz	a	b	c	d			
5190	43.487000	44.689000	46.894000		500	0.5	-42.987000
5230	44.088000	44.489000	46.693000				-43.588000

99% Bandwidth

Test Frequency	99 % Bandwidth						
	MHz						
MHz	a	b	c	d			
5190	36.473000	36.473000	36.473000				
5230	36.473000	36.473000	36.473000				

Measurement uncertainty:	±2.81 dB
---------------------------------	----------

This test report may be reproduced in full only. The document may only be updated by MiCOM Labs personnel. Any changes will be noted in the Document History section of the report.



Title: NetScout Systems Inc. SENSOR4 Product Family
To: FCC 47 CFR Part 15.407 & IC RSS-247
Serial #: NTCT77-U3 Rev A
Issue Date: 12th December 2016
Page: 53 of 269

PORT A 5,190 MHz 802.11n HT-20 Power Spectral Density

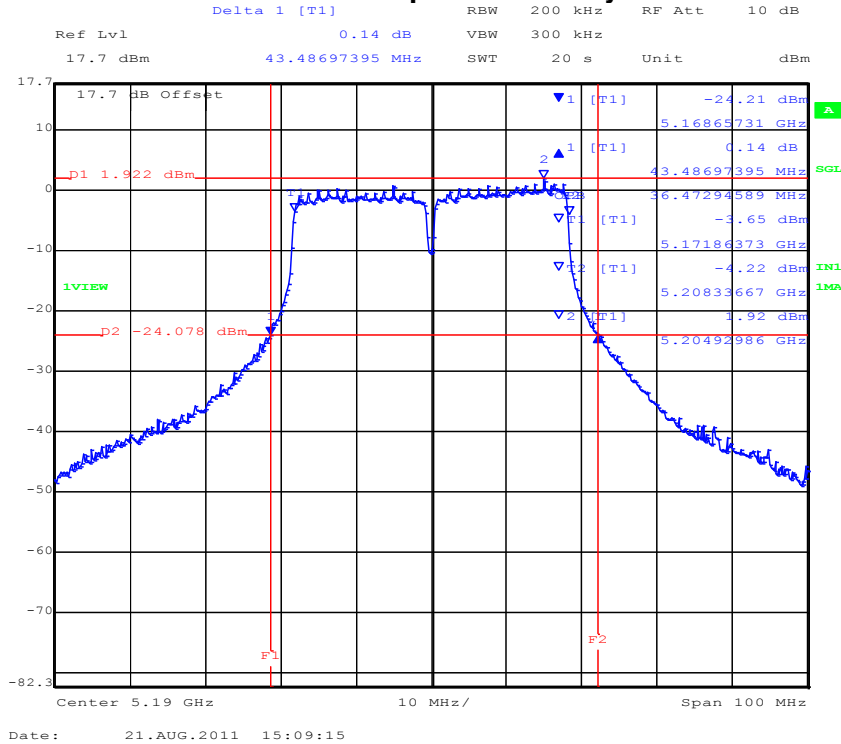

PORT B 5,190 MHz 802.11n HT-20 Power Spectral Density

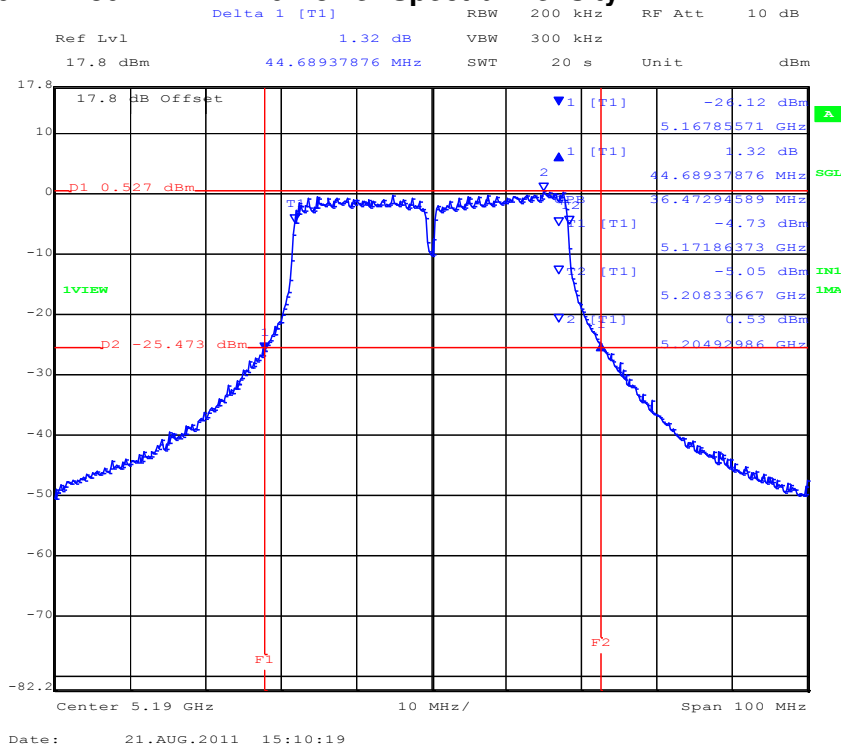

This test report may be reproduced in full only. The document may only be updated by MiCOM Labs personnel. Any changes will be noted in the Document History section of the report.



PORT C 5,190 MHz 802.11n HT-20 Power Spectral Density

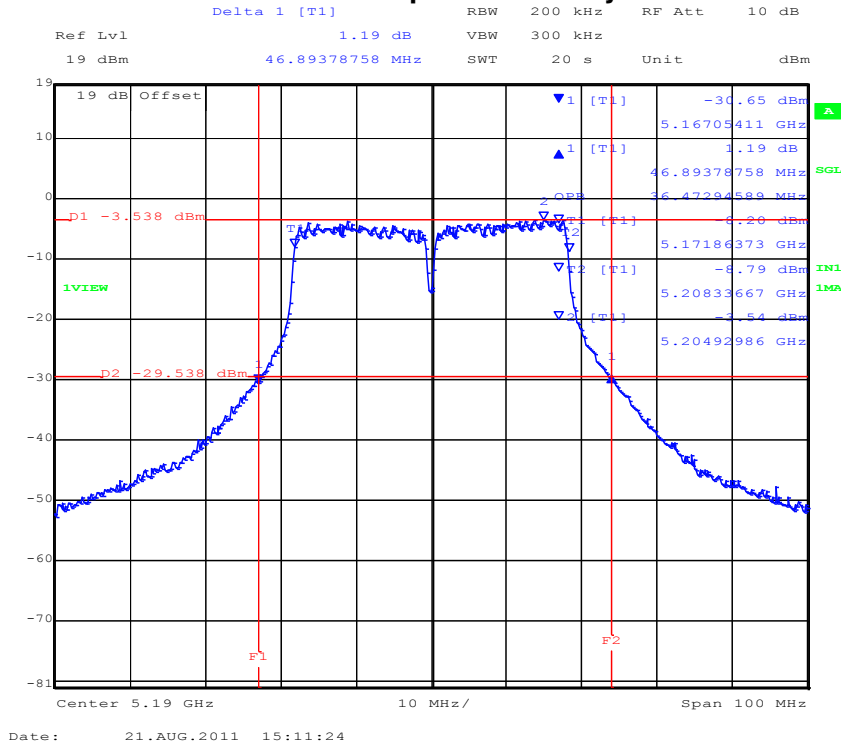

This test report may be reproduced in full only. The document may only be updated by MiCOM Labs personnel. Any changes will be noted in the Document History section of the report.



PORT A 5,230 MHz 802.11n HT-20 Power Spectral Density

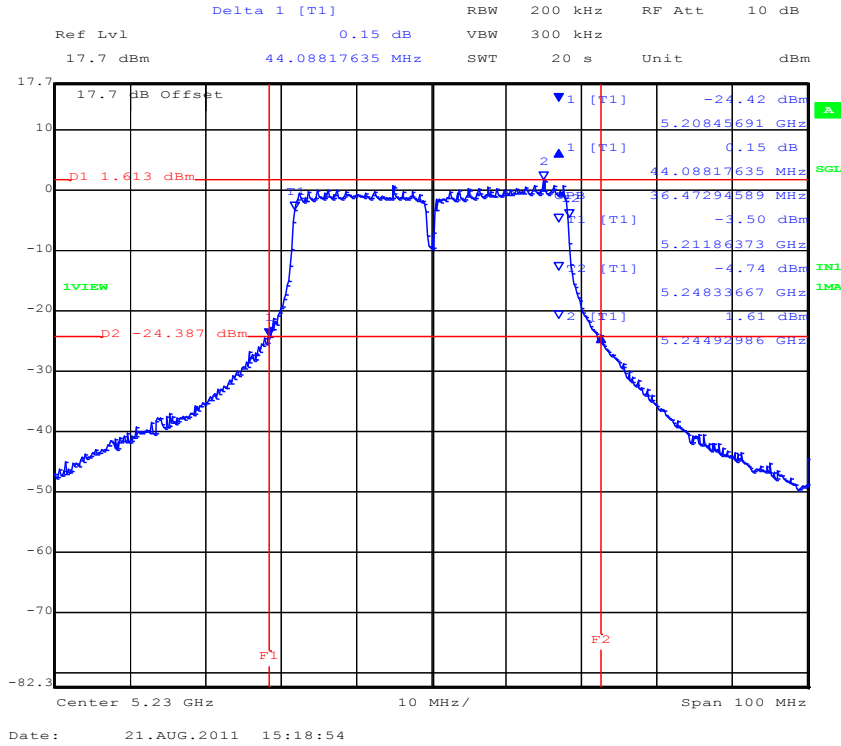

PORT B 5,230 MHz 802.11n HT-20 Power Spectral Density

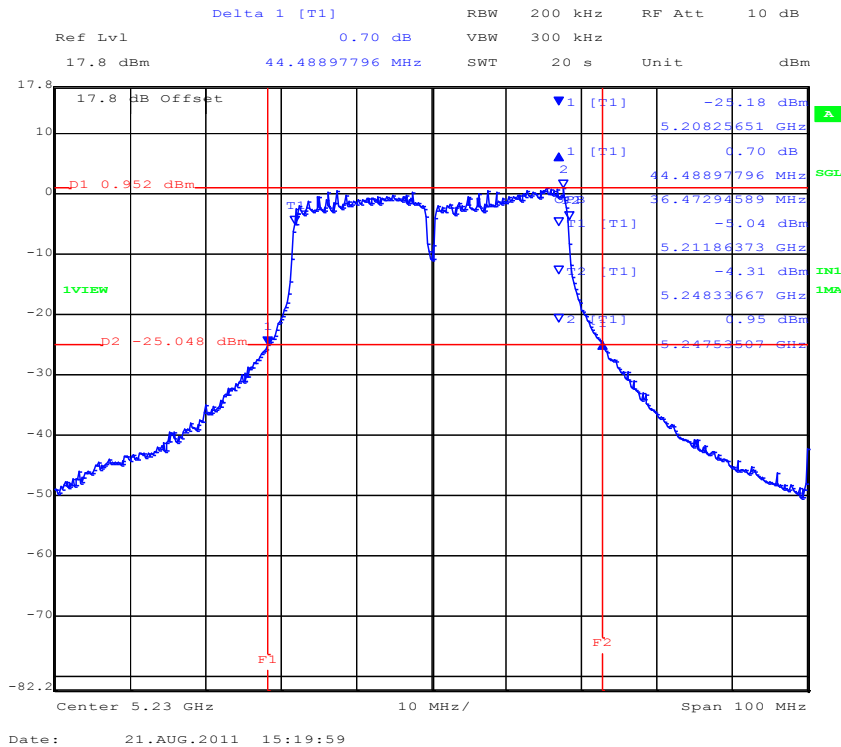

This test report may be reproduced in full only. The document may only be updated by MiCOM Labs personnel. Any changes will be noted in the Document History section of the report.



PORT C 5,230 MHz 802.11n HT-20 Power Spectral Density

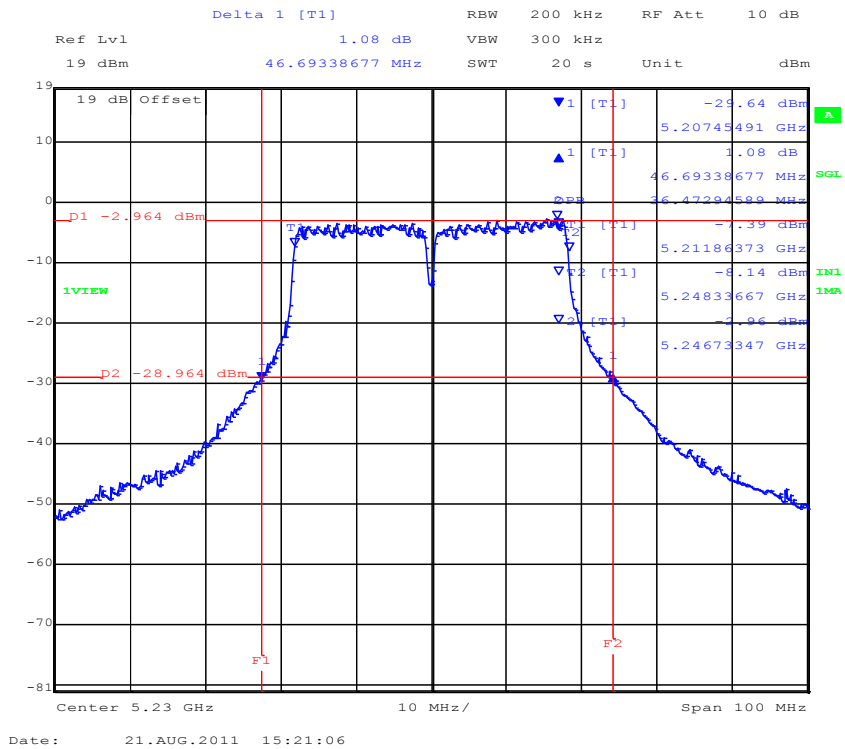

This test report may be reproduced in full only. The document may only be updated by MiCOM Labs personnel. Any changes will be noted in the Document History section of the report.



Title: NetScout Systems Inc. SENSOR4 Product Family
To: FCC 47 CFR Part 15.407 & IC RSS-247
Serial #: NTCT77-U3 Rev A
Issue Date: 12th December 2016
Page: 57 of 269

TABLE OF RESULTS – 802.11a Legacy 5250 – 5350 MHz

Test Conditions:	15.247 (a)(2)	Rel. Humidity (%):	35 to 42
Variant:	802.11a	Ambient Temp. (°C):	19 to 22
TPC:	HIGH	Pressure (mBars):	998 to 1003
Modulation:	ON	Duty Cycle (x):	100
Beam Forming Gain (Y):	N/A dB	Antenna Gain:	0 dBi
Applied Voltage:	48.0 Vdc		
Notes 1:			
Notes 2:			

26 dB Bandwidth

Test Frequency	26 dB Bandwidth				Minimum 6dB Bandwidth Limit		Margin
	MHz				kHz	MHz	MHz
MHz	a	b	c	d			
5260	29.559000	30.661000	28.257000		500	0.5	-27.757000
5300	32.866000	28.357000	28.858000				-27.857000
5320	32.565000	25.952000	28.958000				-25.452000

99% Bandwidth

Test Frequency	99 % Bandwidth						
	MHz						
MHz	a	b	c	d			
5260	17.335000	17.134000	17.134000				
5300	18.236000	16.733000	17.134000				
5320	18.838000	16.733000	17.134000				

Measurement uncertainty:	±2.81 dB
---------------------------------	----------

This test report may be reproduced in full only. The document may only be updated by MiCOM Labs personnel. Any changes will be noted in the Document History section of the report.



Title: NetScout Systems Inc. SENSOR4 Product Family
To: FCC 47 CFR Part 15.407 & IC RSS-247
Serial #: NTCT77-U3 Rev A
Issue Date: 12th December 2016
Page: 58 of 269

PORT A 5,260 MHz 802.11a Legacy 26 dB and 99 % Bandwidth

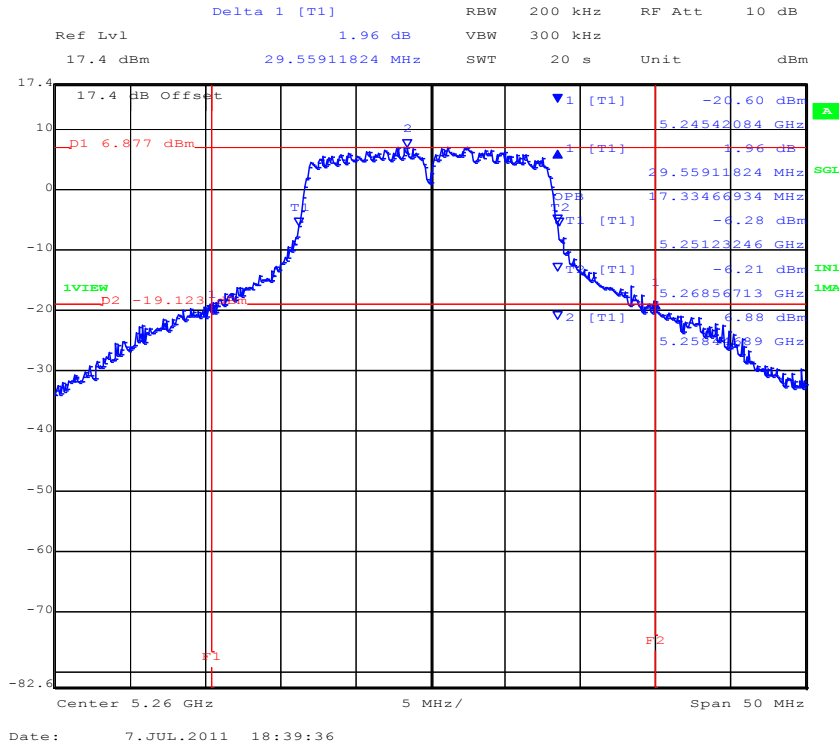

PORT B 5,260 MHz 802.11a Legacy 26 dB and 99 % Bandwidth

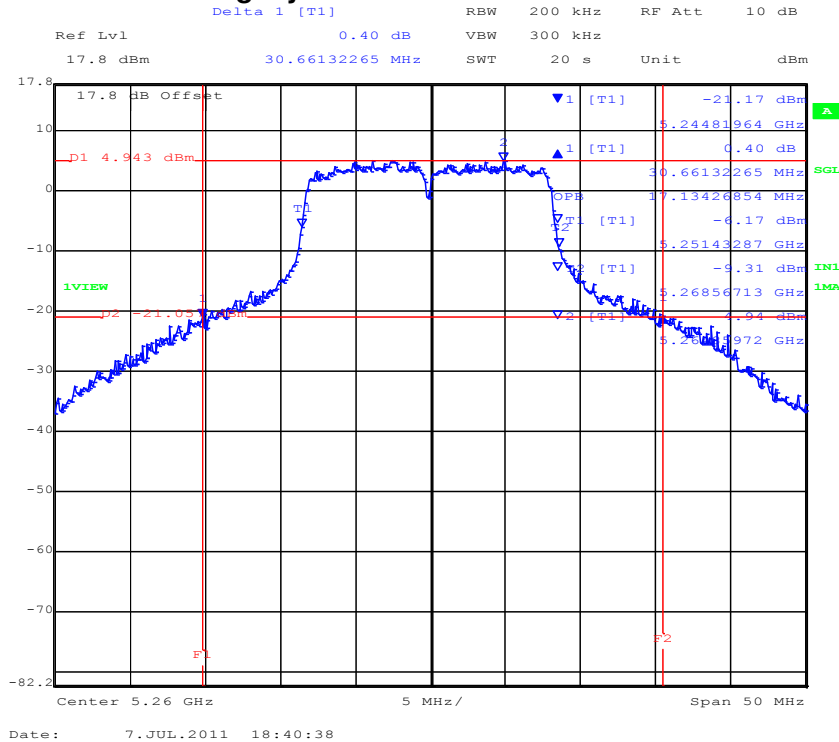

This test report may be reproduced in full only. The document may only be updated by MiCOM Labs personnel. Any changes will be noted in the Document History section of the report.



Title: NetScout Systems Inc. SENSOR4 Product Family
To: FCC 47 CFR Part 15.407 & IC RSS-247
Serial #: NTCT77-U3 Rev A
Issue Date: 12th December 2016
Page: 59 of 269

PORT C 5,260 MHz 802.11a Legacy 26 dB and 99 % Bandwidth

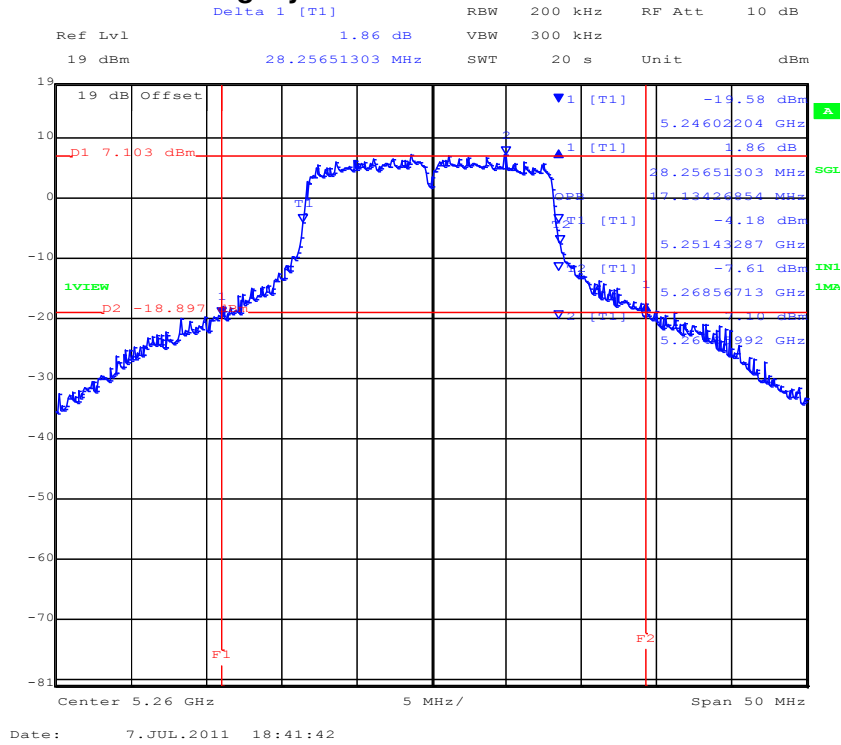

PORT A 5300 MHz 802.11a Legacy 26 dB and 99 % Bandwidth

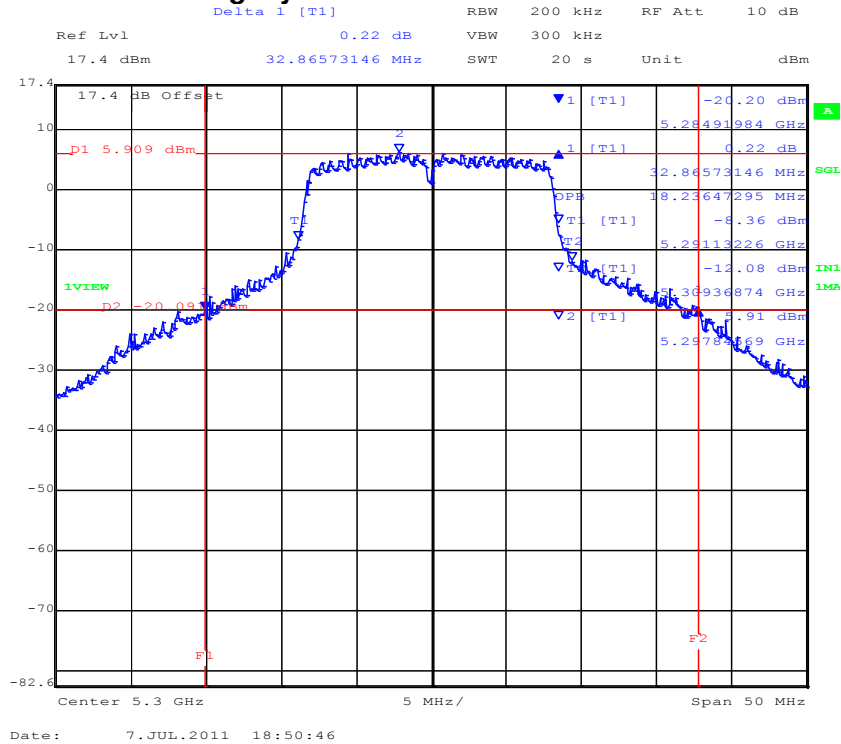

This test report may be reproduced in full only. The document may only be updated by MiCOM Labs personnel. Any changes will be noted in the Document History section of the report.



PORT B 5,300 MHz 802.11a Legacy 26 dB and 99 % Bandwidth

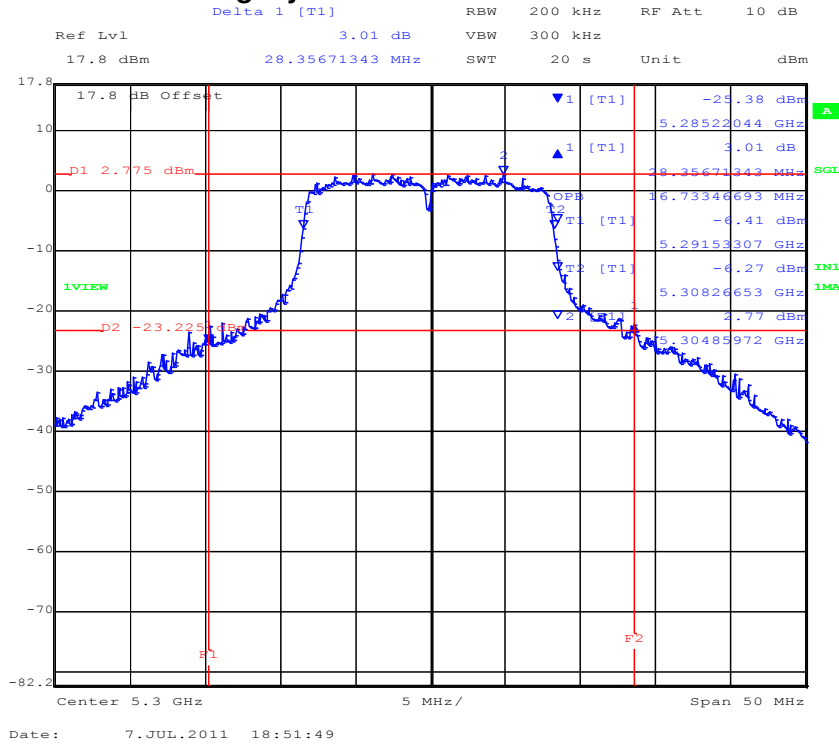

PORT C 5,300 MHz 802.11a Legacy 26 dB and 99 % Bandwidth

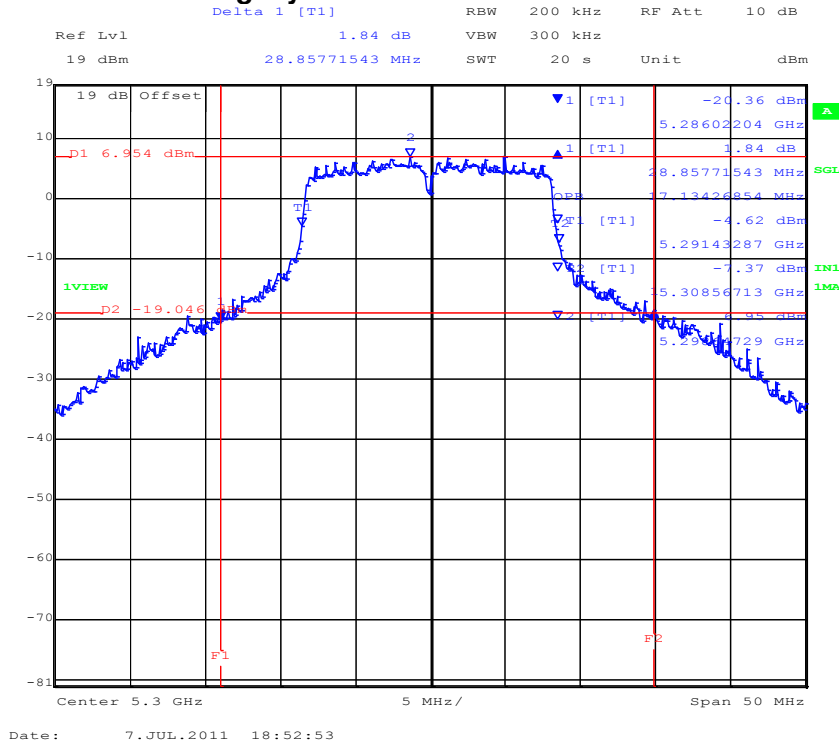

This test report may be reproduced in full only. The document may only be updated by MiCOM Labs personnel. Any changes will be noted in the Document History section of the report.



PORT A 5,320 MHz 802.11a Legacy 26 dB and 99 % Bandwidth

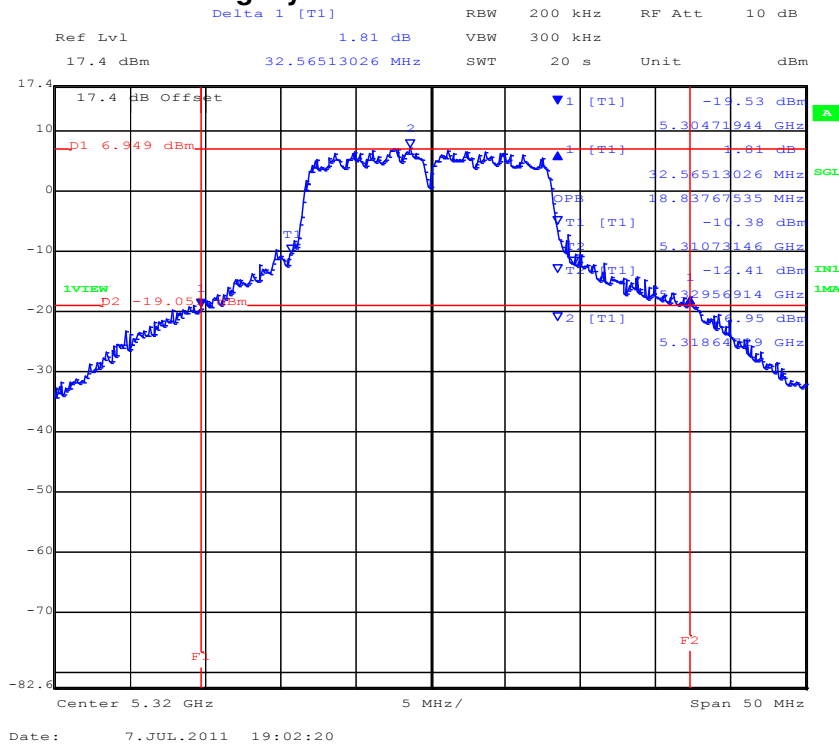

PORT B 5,320 MHz 802.11a Legacy 26 dB and 99 % Bandwidth

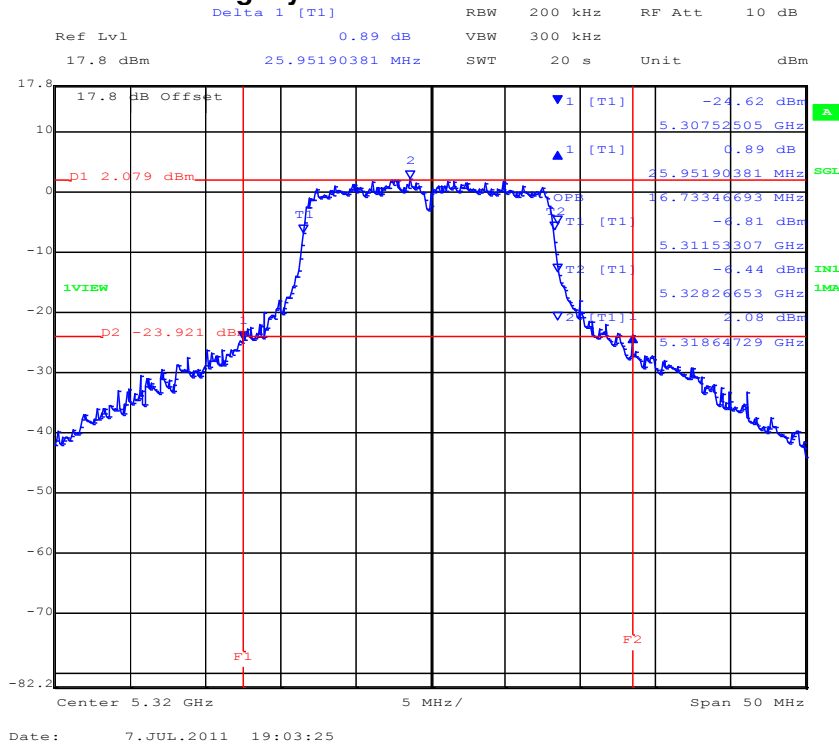

This test report may be reproduced in full only. The document may only be updated by MiCOM Labs personnel. Any changes will be noted in the Document History section of the report.



Title: NetScout Systems Inc. SENSOR4 Product Family
To: FCC 47 CFR Part 15.407 & IC RSS-247
Serial #: NTCT77-U3 Rev A
Issue Date: 12th December 2016
Page: 63 of 269

Measurement Results for 26 dB and 99 % Operational Bandwidth(s)

TABLE OF RESULTS – 802.11n HT20 5250 – 5350 MHz

Test Conditions:	15.247 (a)(2)	Rel. Humidity (%):	35 to 42
Variant:	802.11n HT-20	Ambient Temp. (°C):	19 to 22
TPC:	HIGH	Pressure (mBars):	998 to 1003
Modulation:	ON	Duty Cycle (x):	100
Beam Forming Gain (Y):	N/A dB	Antenna Gain:	0 dBi
Applied Voltage:	48.0 Vdc		
Notes 1:			
Notes 2:			

26 dB Bandwidth

Test Frequency	26 dB Bandwidth				Minimum 6dB Bandwidth Limit		Margin
	MHz				kHz	MHz	
MHz	a	b	c	d			
5260	29.960000	28.858000	28.858000		500	0.5	-28.358000
5300	32.766000	26.754000	32.766000				-26.254000
5320	36.273000	25.150000	30.962000				-24.650000

99% Bandwidth

Test Frequency	99 % Bandwidth					
	MHz					
MHz	a	b	c	d		
5260	18.136000	18.036000	18.036000			
5300	18.938000	17.936000	18.236000			
5320	19.940000	17.936000	18.236000			

Measurement uncertainty:	±2.81 dB
---------------------------------	----------

This test report may be reproduced in full only. The document may only be updated by MiCOM Labs personnel. Any changes will be noted in the Document History section of the report.



PORT A 5,260 MHz 802.11n HT-20 26 dB and 99 % Bandwidth

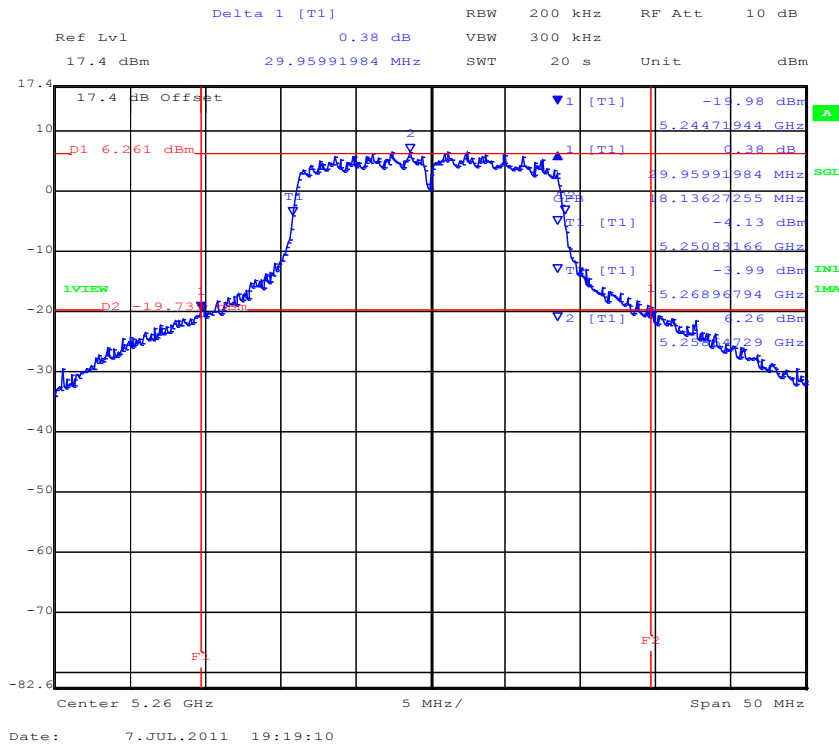

PORT B 5,260 MHz 802.11n HT-20 26 dB and 99 % Bandwidth

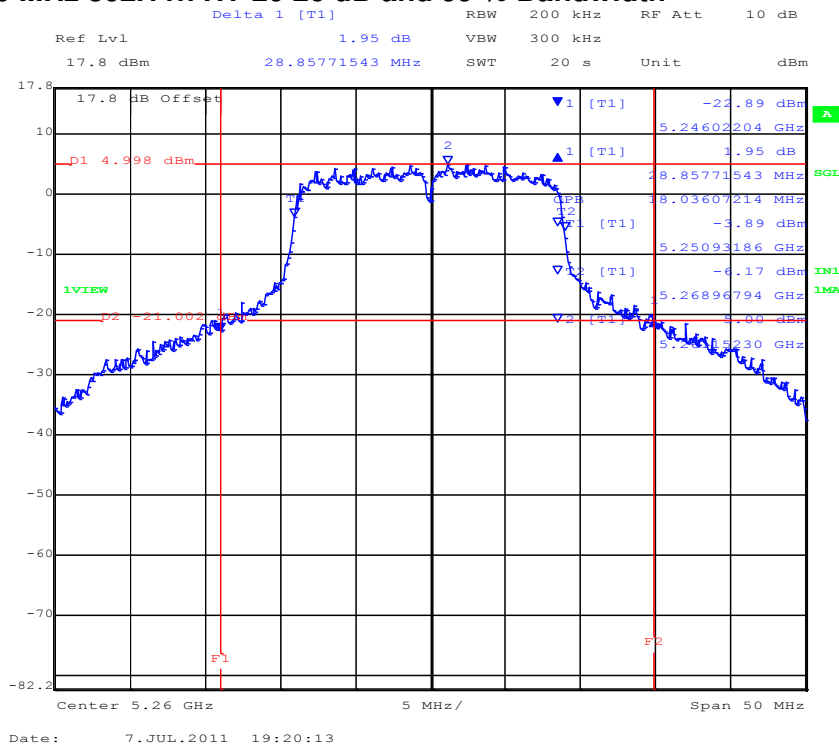

This test report may be reproduced in full only. The document may only be updated by MiCOM Labs personnel. Any changes will be noted in the Document History section of the report.



PORT C 5,260 MHz 802.11n HT-20 26 dB and 99 % Bandwidth

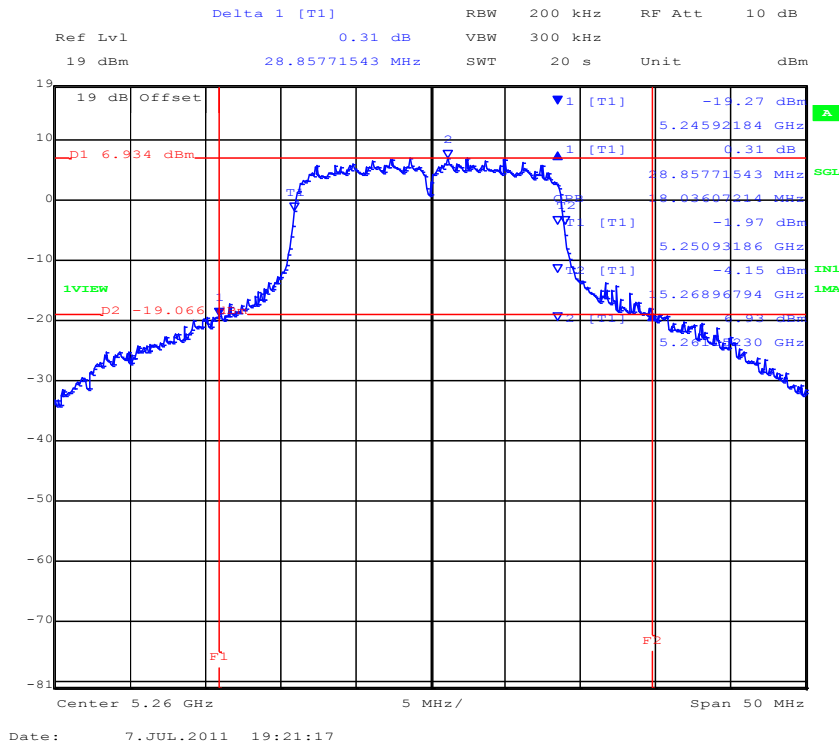

PORT A 5300 MHz 802.11n HT-20 26 dB and 99 % Bandwidth

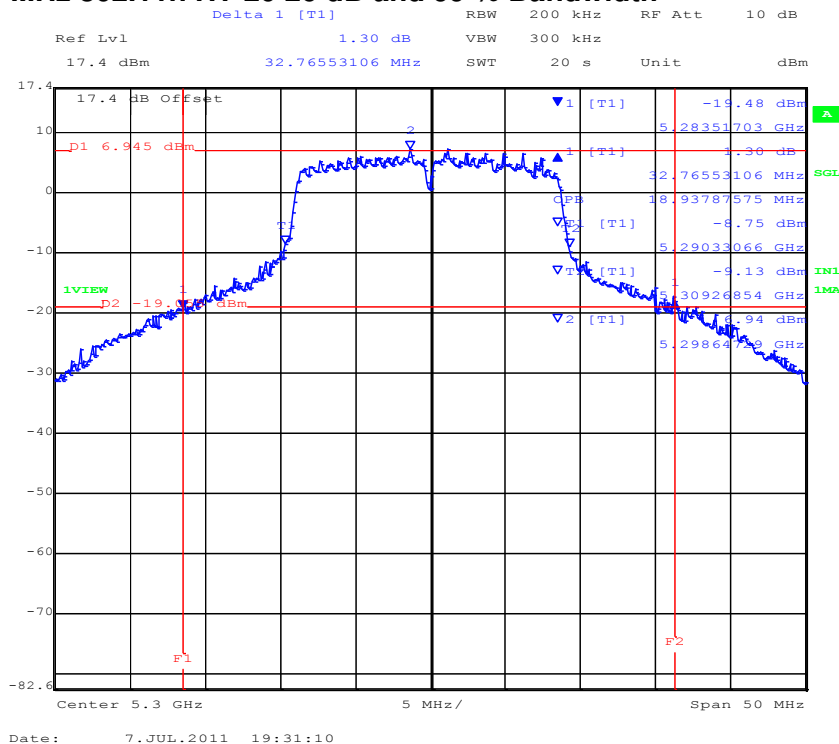

This test report may be reproduced in full only. The document may only be updated by MiCOM Labs personnel. Any changes will be noted in the Document History section of the report.



PORT B 5,300 MHz 802.11n HT-20 26 dB and 99 % Bandwidth

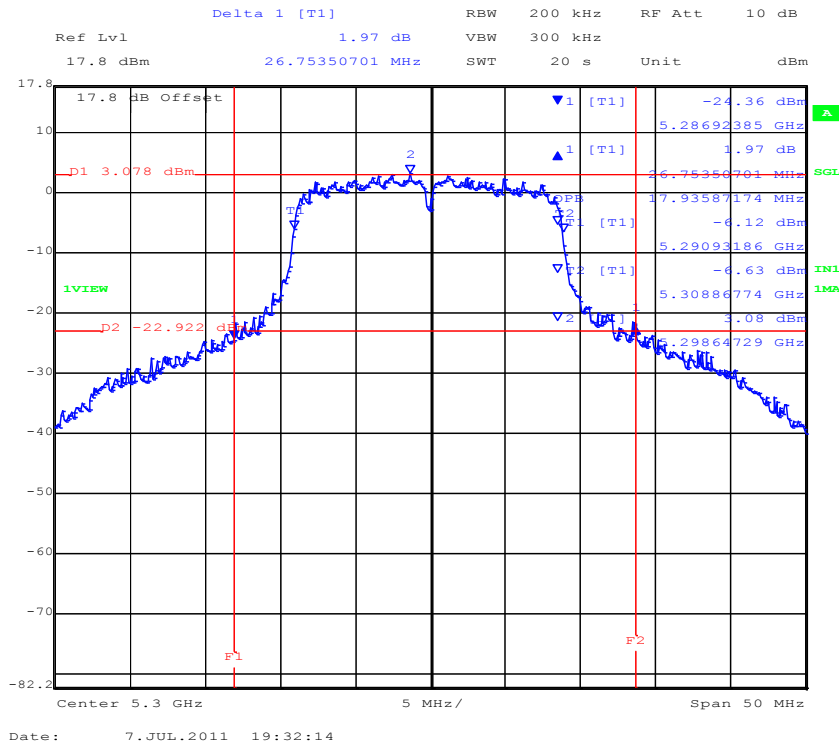

PORT C 5,300 MHz 802.11n HT-20 26 dB and 99 % Bandwidth

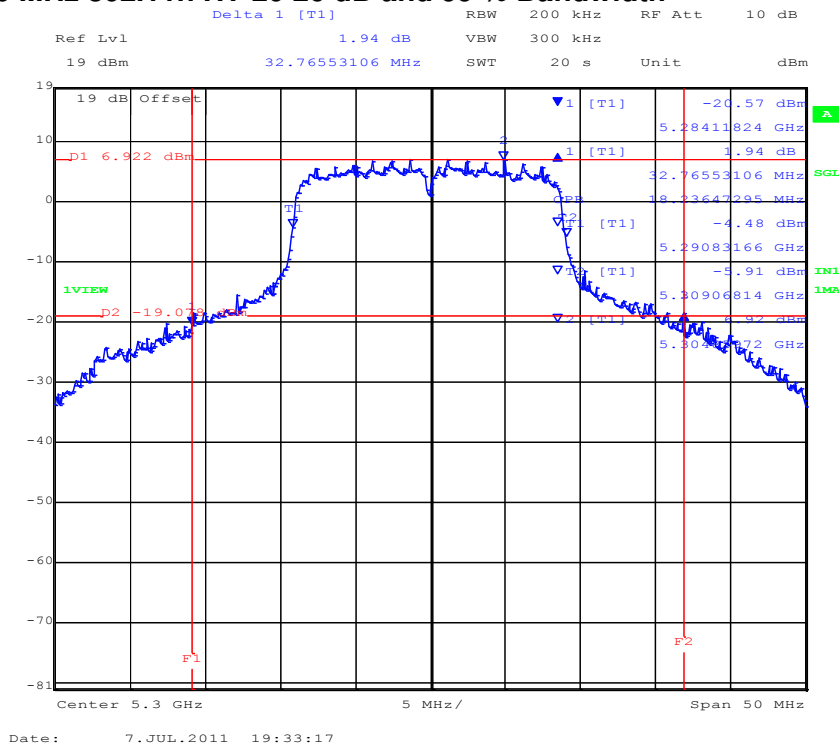

This test report may be reproduced in full only. The document may only be updated by MiCOM Labs personnel. Any changes will be noted in the Document History section of the report.



PORT A 5,320 MHz 802.11n HT-20 26 dB and 99 % Bandwidth

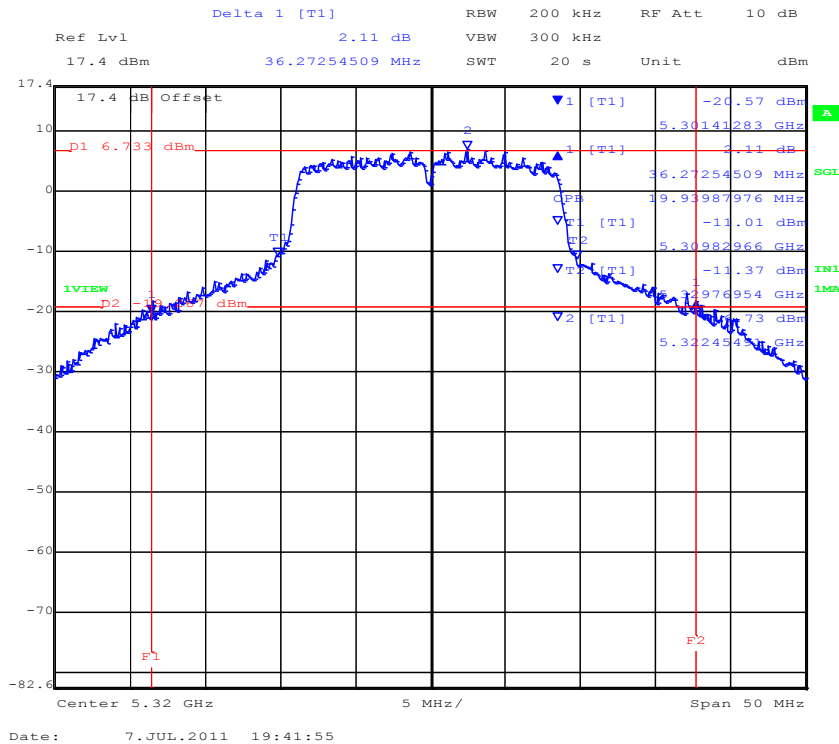

PORT B 5,320 MHz 802.11n HT-20 26 dB and 99 % Bandwidth

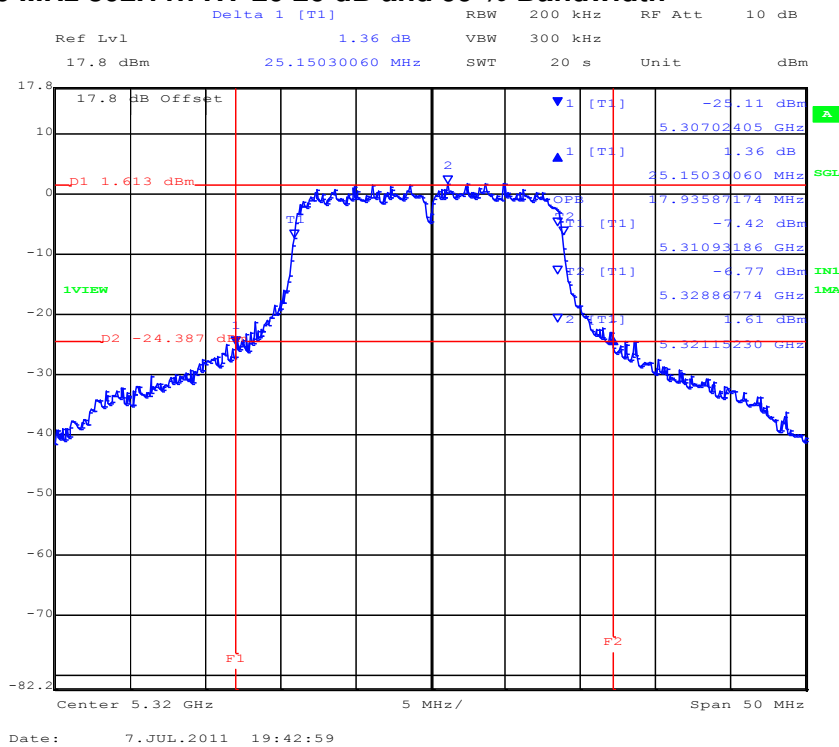

This test report may be reproduced in full only. The document may only be updated by MiCOM Labs personnel. Any changes will be noted in the Document History section of the report.



Title: NetScout Systems Inc. SENSOR4 Product Family
To: FCC 47 CFR Part 15.407 & IC RSS-247
Serial #: NTCT77-U3 Rev A
Issue Date: 12th December 2016
Page: 68 of 269

PORT C 5,320 MHz 802.11n HT-20 26 dB and 99 % Bandwidth

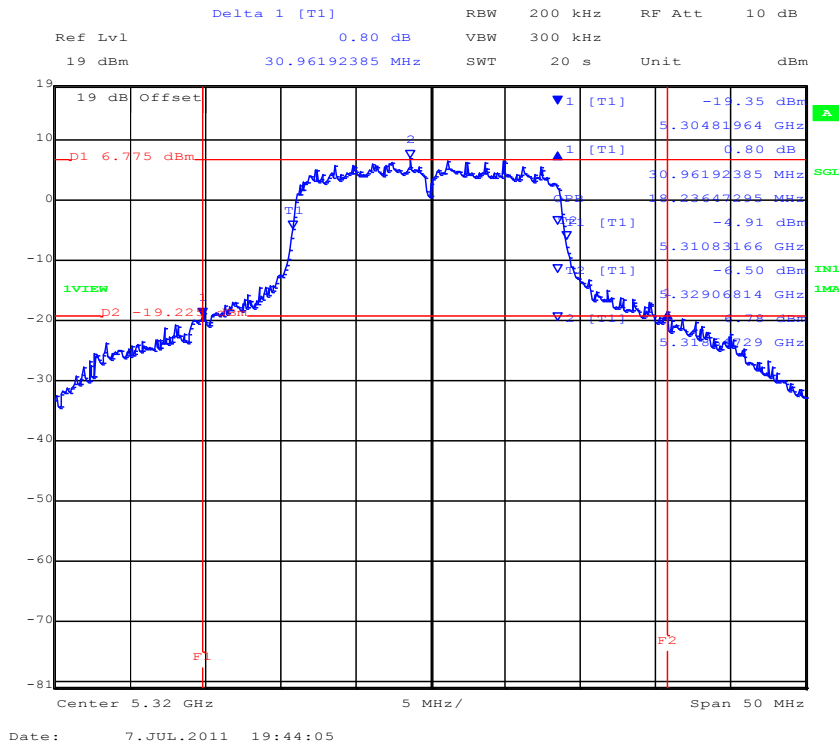

This test report may be reproduced in full only. The document may only be updated by MiCOM Labs personnel. Any changes will be noted in the Document History section of the report.



Title: NetScout Systems Inc. SENSOR4 Product Family
To: FCC 47 CFR Part 15.407 & IC RSS-247
Serial #: NTCT77-U3 Rev A
Issue Date: 12th December 2016
Page: 69 of 269

Measurement Results for 26 dB and 99 % Operational Bandwidth(s)

TABLE OF RESULTS – 802.11n HT40 5250 – 5350 MHz

Test Conditions:	15.247 (a)(2)	Rel. Humidity (%):	35 to 42
Variant:	802.11n HT-40	Ambient Temp. (°C):	19 to 22
TPC:	HIGH	Pressure (mBars):	998 to 1003
Modulation:	ON	Duty Cycle (x):	100
Beam Forming Gain (Y):	N/A dB	Antenna Gain:	0 dBi
Applied Voltage:	48.0 Vdc		
Notes 1:			
Notes 2:			

26 dB Bandwidth

Test Frequency	26 dB Bandwidth				Minimum 6dB Bandwidth Limit		Margin
	MHz				kHz	MHz	
MHz	a	b	c	d			
5270	46.894000	47.896000	47.495000		500	0.5	-46.394000
5310	61.122000	45.892000	47.094000				-45.392000

99% Bandwidth

Test Frequency	99 % Bandwidth					
	MHz					
MHz	a	b	c	d		
5270	36.473000	36.473000	36.673000			
5310	36.673000	36.473000	36.473000			

Measurement uncertainty:	±2.81 dB
---------------------------------	----------

This test report may be reproduced in full only. The document may only be updated by MiCOM Labs personnel. Any changes will be noted in the Document History section of the report.



PORT A 5,270 MHz 802.11n HT-40 26 dB and 99 % Bandwidth

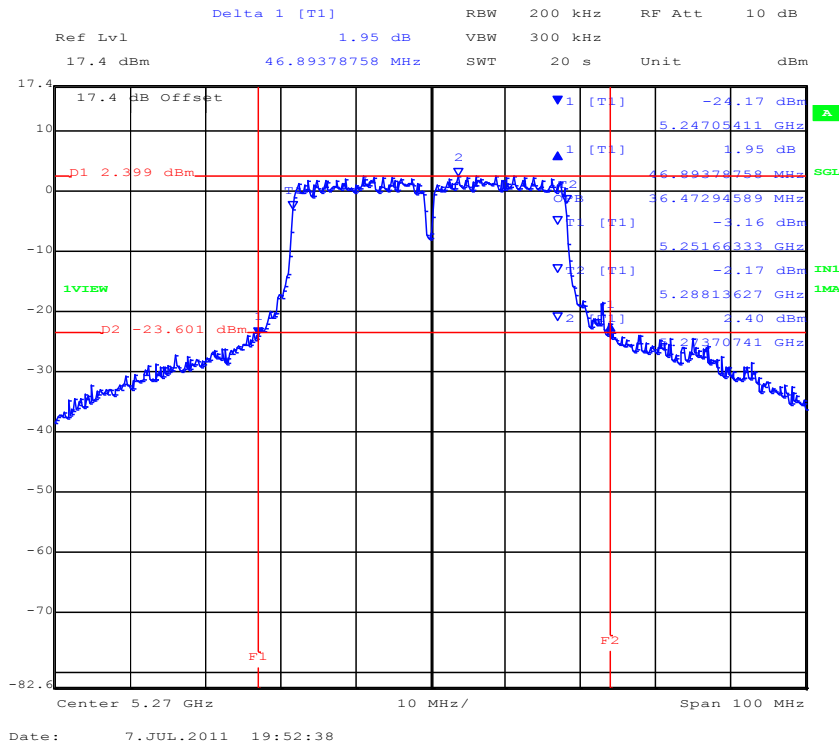

PORT B 5,270 MHz 802.11n HT-40 26 dB and 99 % Bandwidth

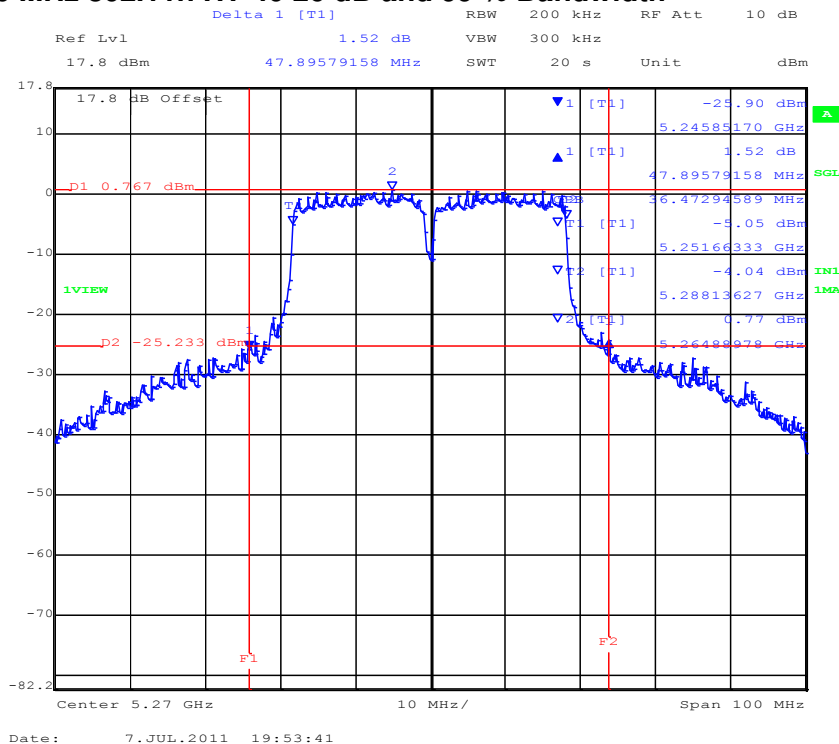

This test report may be reproduced in full only. The document may only be updated by MiCOM Labs personnel. Any changes will be noted in the Document History section of the report.



PORT C 5,270 MHz 802.11n HT-40 26 dB and 99 % Bandwidth

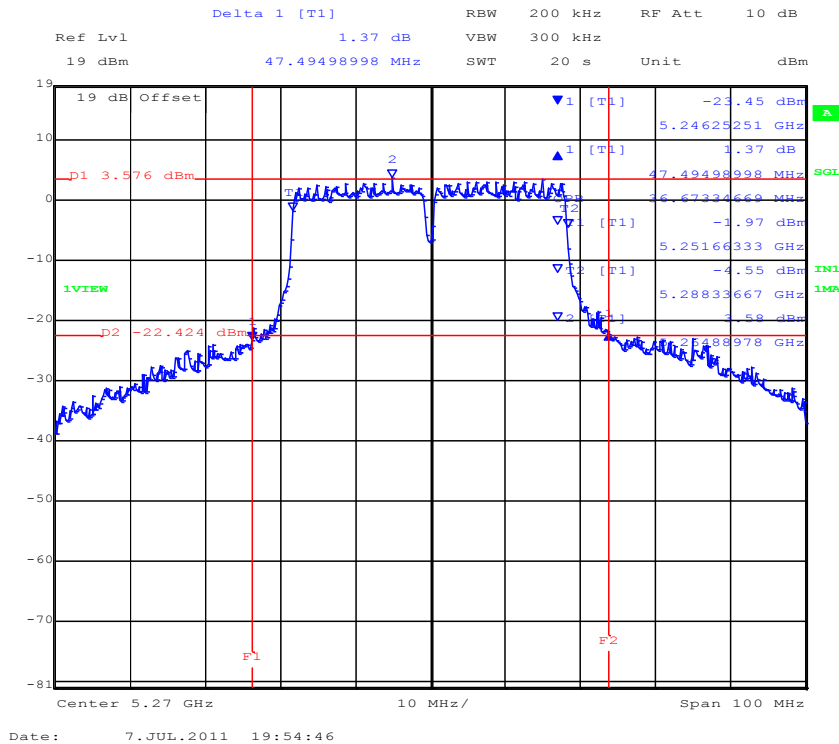

PORT A 5,310 MHz 802.11n HT-40 26 dB and 99 % Bandwidth

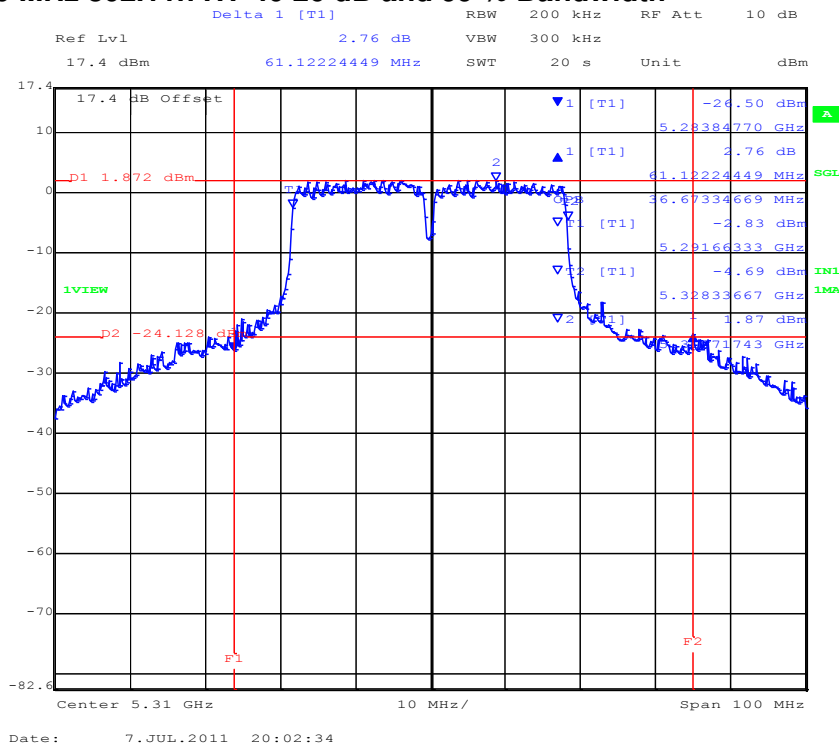

This test report may be reproduced in full only. The document may only be updated by MiCOM Labs personnel. Any changes will be noted in the Document History section of the report.



PORT B 5,310 MHz 802.11n HT-40 26 dB and 99 % Bandwidth

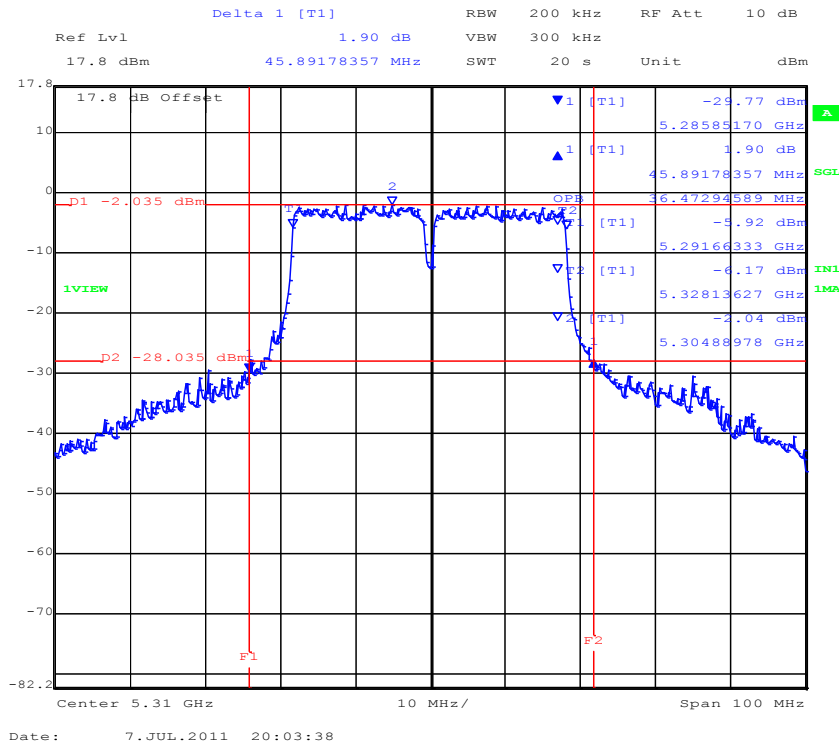

PORT C 5,310 MHz 802.11n HT-40 26 dB and 99 % Bandwidth

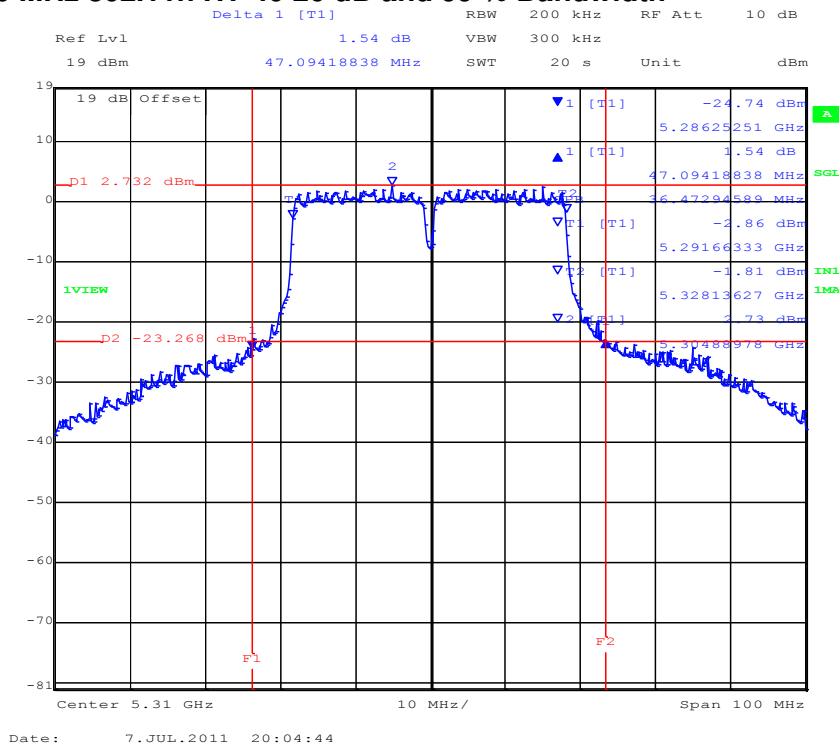

This test report may be reproduced in full only. The document may only be updated by MiCOM Labs personnel. Any changes will be noted in the Document History section of the report.



Title: NetScout Systems Inc. SENSOR4 Product Family
To: FCC 47 CFR Part 15.407 & IC RSS-247
Serial #: NTCT77-U3 Rev A
Issue Date: 12th December 2016
Page: 73 of 269

TABLE OF RESULTS – 802.11a Legacy 5500 – 5700 MHz

Test Conditions:	15.247 (a)(2)	Rel. Humidity (%):	35 to 42
Variant:	802.11a	Ambient Temp. (°C):	19 to 22
TPC:	HIGH	Pressure (mBars):	998 to 1003
Modulation:	ON	Duty Cycle (x):	100
Beam Forming Gain (Y):	N/A dB	Antenna Gain:	0 dBi
Applied Voltage:	48.0 Vdc		
Notes 1:			
Notes 2:			

26 dB Bandwidth

Test Frequency	26 dB Bandwidth				Minimum 6dB Bandwidth Limit		Margin
	MHz				kHz	MHz	
MHz	a	b	c	d			
5500	24.850000	25.150000	23.747000		500	0.5	-23.247000
5580	26.653000	28.357000	27.956000				-26.153000
5700	28.257000	22.044000	24.549000				-21.544000

99% Bandwidth

Test Frequency	99 % Bandwidth						
	MHz						
MHz	a	b	c	d			
5500	16.733000	16.733000	16.733000				
5580	16.934000	16.934000	16.934000				
5700	16.934000	16.633000	16.733000				

Measurement uncertainty:	±2.81 dB
---------------------------------	----------

This test report may be reproduced in full only. The document may only be updated by MiCOM Labs personnel. Any changes will be noted in the Document History section of the report.



PORT C 5,500 MHz 802.11a Legacy 26 dB and 99 % Bandwidth

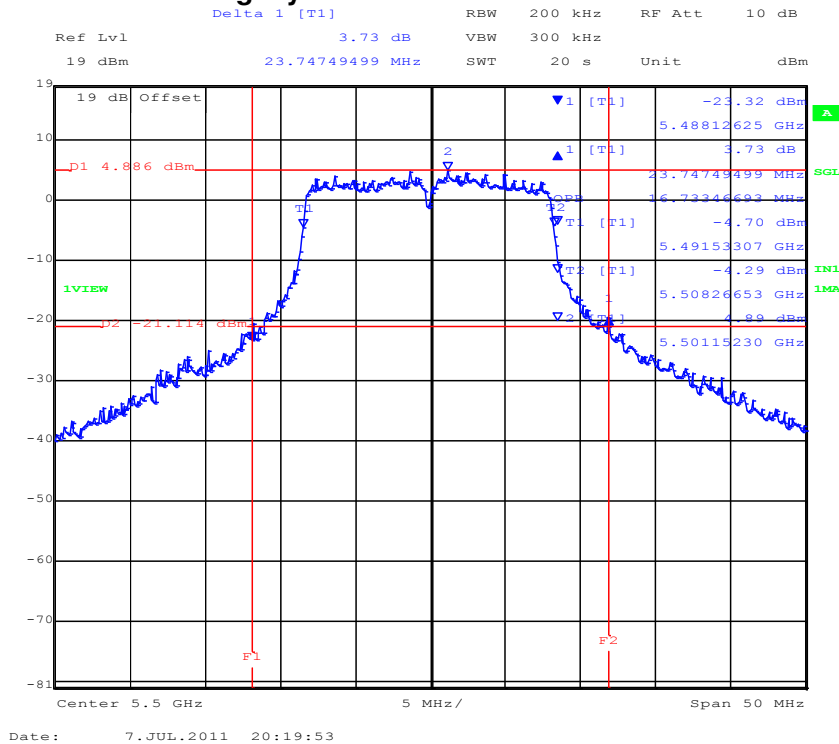

PORT A 5,580 MHz 802.11a Legacy 26 dB and 99 % Bandwidth

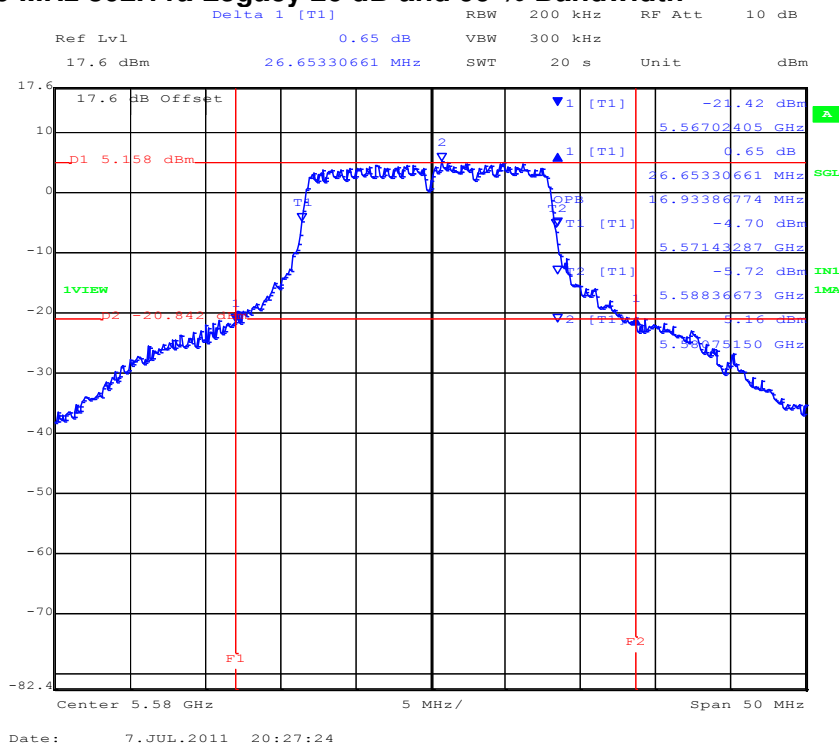

This test report may be reproduced in full only. The document may only be updated by MiCOM Labs personnel. Any changes will be noted in the Document History section of the report.



PORT B 5,580 MHz 802.11a Legacy 26 dB and 99 % Bandwidth

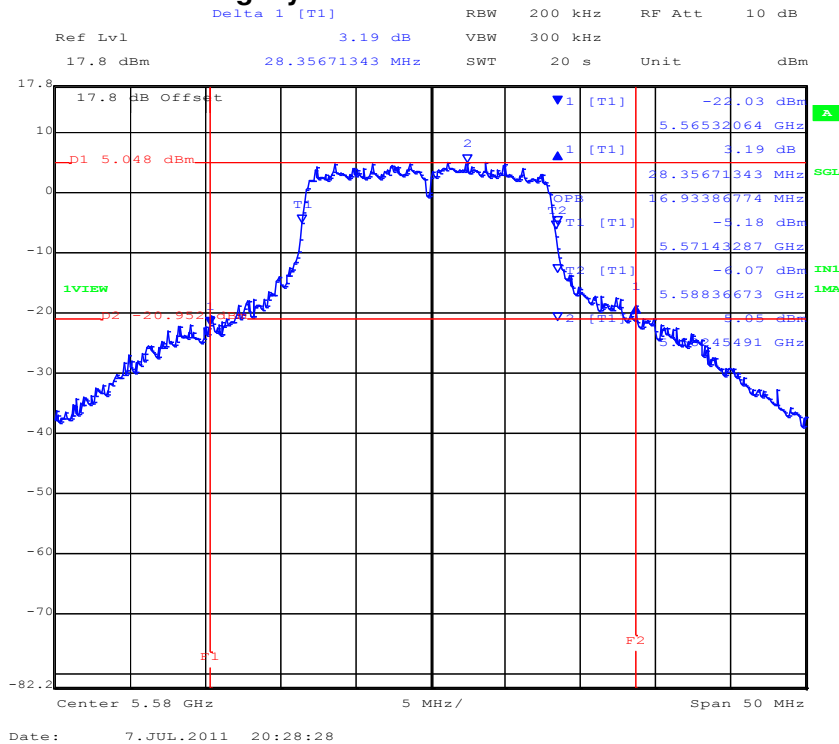

PORT C 5,580 MHz 802.11a Legacy 26 dB and 99 % Bandwidth

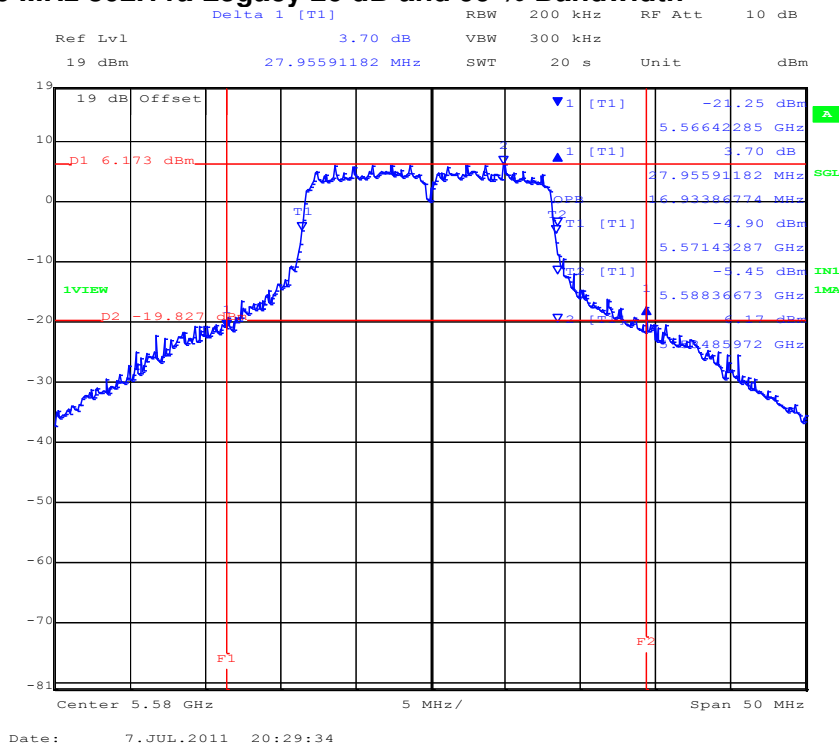

This test report may be reproduced in full only. The document may only be updated by MiCOM Labs personnel. Any changes will be noted in the Document History section of the report.



Title: NetScout Systems Inc. SENSOR4 Product Family
To: FCC 47 CFR Part 15.407 & IC RSS-247
Serial #: NTCT77-U3 Rev A
Issue Date: 12th December 2016
Page: 77 of 269

PORT A 5,700 MHz 802.11a Legacy 26 dB and 99 % Bandwidth

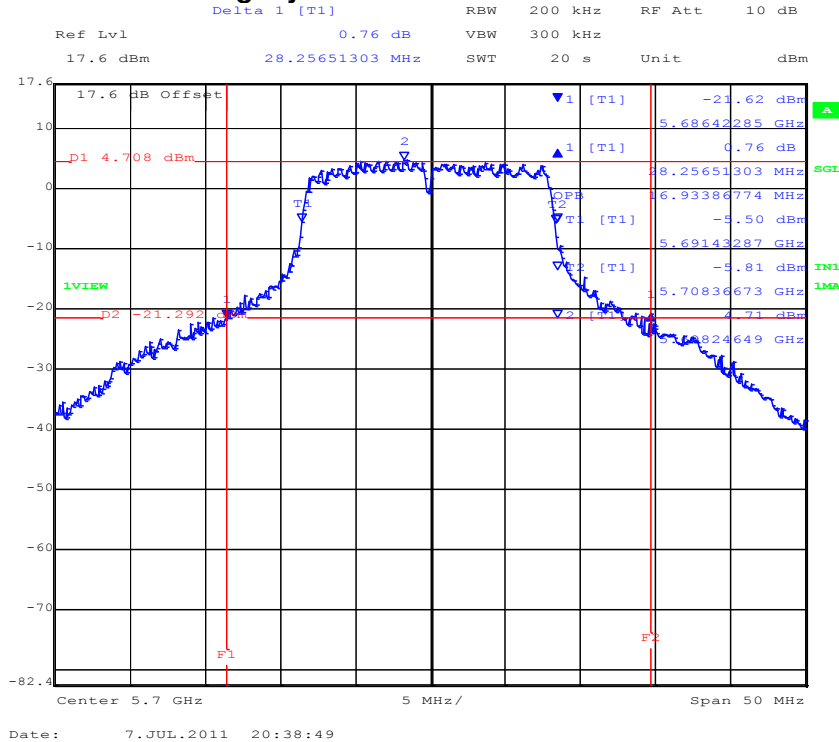

PORT B 5,700 MHz 802.11a Legacy 26 dB and 99 % Bandwidth

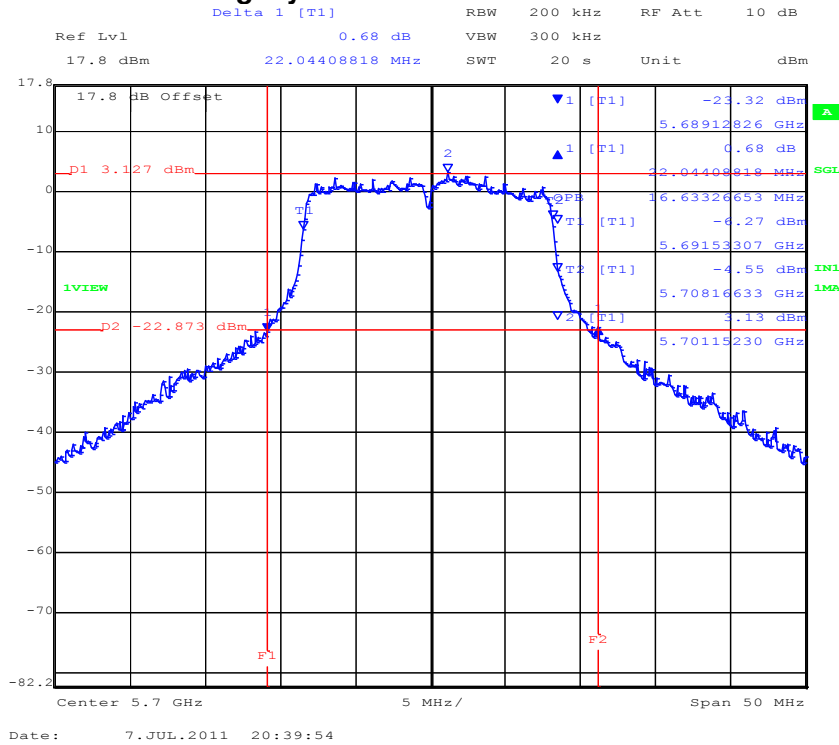

This test report may be reproduced in full only. The document may only be updated by MiCOM Labs personnel. Any changes will be noted in the Document History section of the report.



PORT C 5,700 MHz 802.11a Legacy 26 dB and 99 % Bandwidth

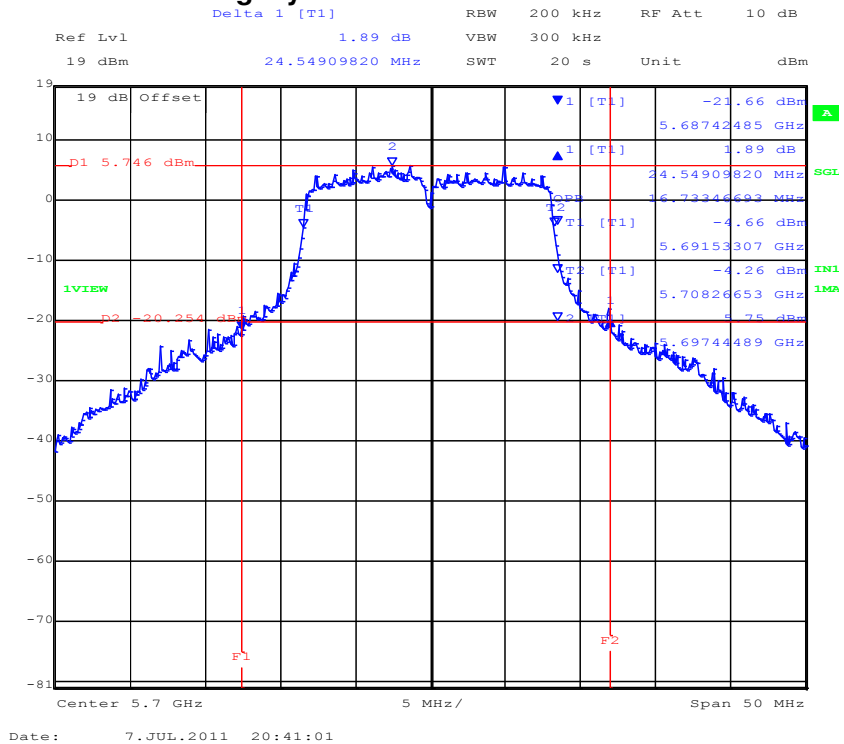

This test report may be reproduced in full only. The document may only be updated by MiCOM Labs personnel. Any changes will be noted in the Document History section of the report.



Title: NetScout Systems Inc. SENSOR4 Product Family
To: FCC 47 CFR Part 15.407 & IC RSS-247
Serial #: NTCT77-U3 Rev A
Issue Date: 12th December 2016
Page: 79 of 269

TABLE OF RESULTS – 802.11n HT-20 5500 – 5700 MHz

Test Conditions:	15.247 (a)(2)	Rel. Humidity (%):	35 to 42
Variant:	802.11n HT-20	Ambient Temp. (°C):	19 to 22
TPC:	HIGH	Pressure (mBars):	998 to 1003
Modulation:	ON	Duty Cycle (x):	100
Beam Forming Gain (Y):	N/A dB	Antenna Gain:	0 dBi
Applied Voltage:	48.0 Vdc		
Notes 1:			
Notes 2:			

26 dB Bandwidth

Test Frequency	26 dB Bandwidth				Minimum 6dB Bandwidth Limit		Margin
	MHz				kHz	MHz	
MHz	a	b	c	d			
5500	24.950000	26.353000	24.248000		500	0.5	-23.748000
5580	27.355000	29.259000	31.764000				-26.855000
5700	26.253000	23.046000	24.850000				-22.546000

99% Bandwidth

Test Frequency	99 % Bandwidth						
	MHz						
MHz	a	b	c	d			
5500	17.936000	17.836000	17.735000				
5580	18.136000	18.136000	18.136000				
5700	18.036000	17.735000	17.836000				

Measurement uncertainty:	±2.81 dB
---------------------------------	----------

This test report may be reproduced in full only. The document may only be updated by MiCOM Labs personnel. Any changes will be noted in the Document History section of the report.



Title: NetScout Systems Inc. SENSOR4 Product Family
To: FCC 47 CFR Part 15.407 & IC RSS-247
Serial #: NTCT77-U3 Rev A
Issue Date: 12th December 2016
Page: 80 of 269

PORT A 5,500 MHz 802.11n HT-20 26 dB and 99 % Bandwidth

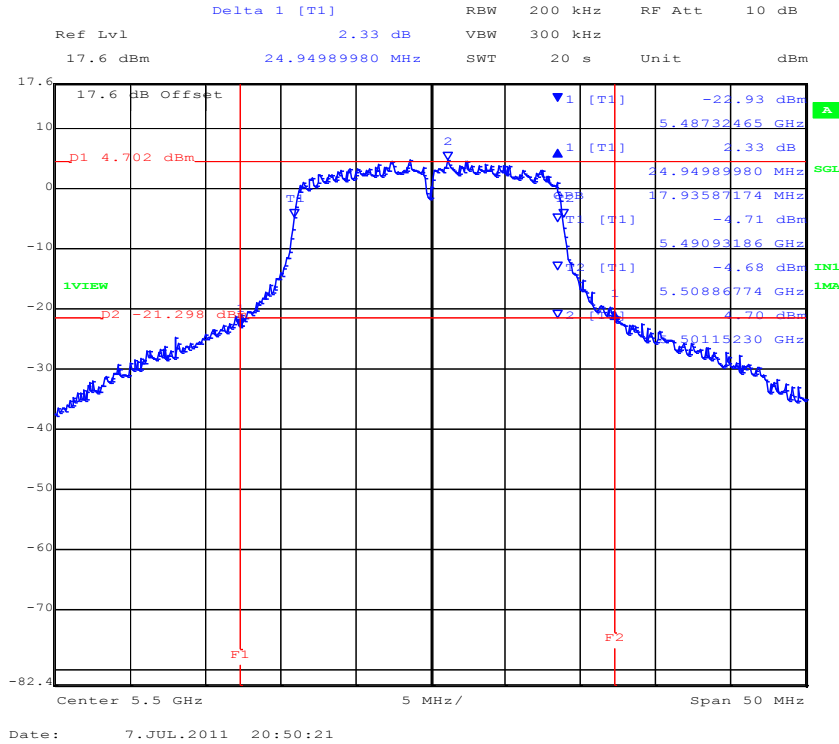

PORT B 5,500 MHz 802.11n HT-20 26 dB and 99 % Bandwidth

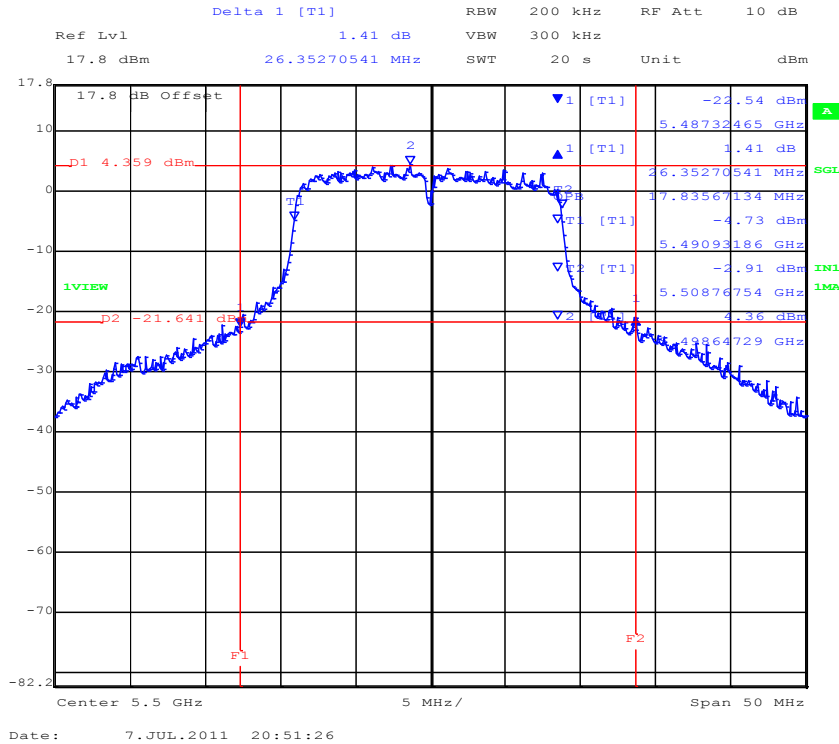

This test report may be reproduced in full only. The document may only be updated by MiCOM Labs personnel. Any changes will be noted in the Document History section of the report.



PORT C 5,500 MHz 802.11n HT-20 26 dB and 99 % Bandwidth

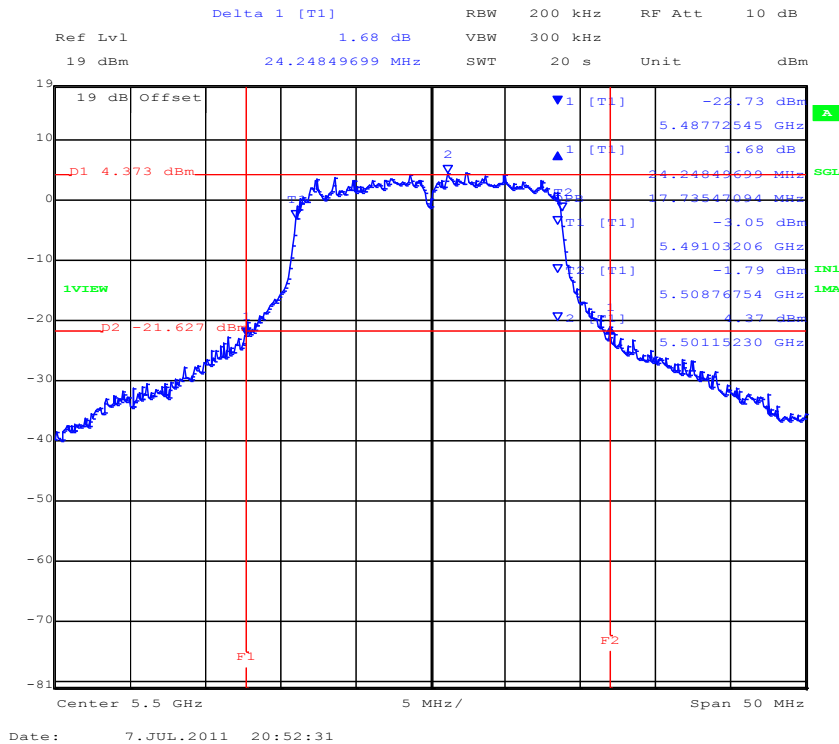

PORT A 5,580 MHz 802.11n HT-20 26 dB and 99 % Bandwidth

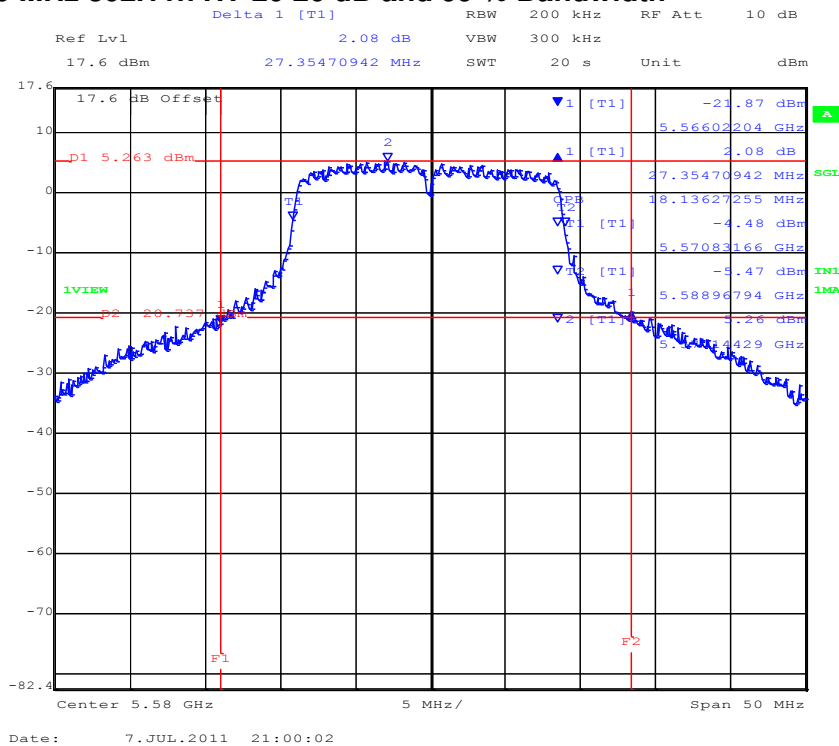

This test report may be reproduced in full only. The document may only be updated by MiCOM Labs personnel. Any changes will be noted in the Document History section of the report.



PORT A 5,700 MHz 802.11n HT-20 26 dB and 99 % Bandwidth

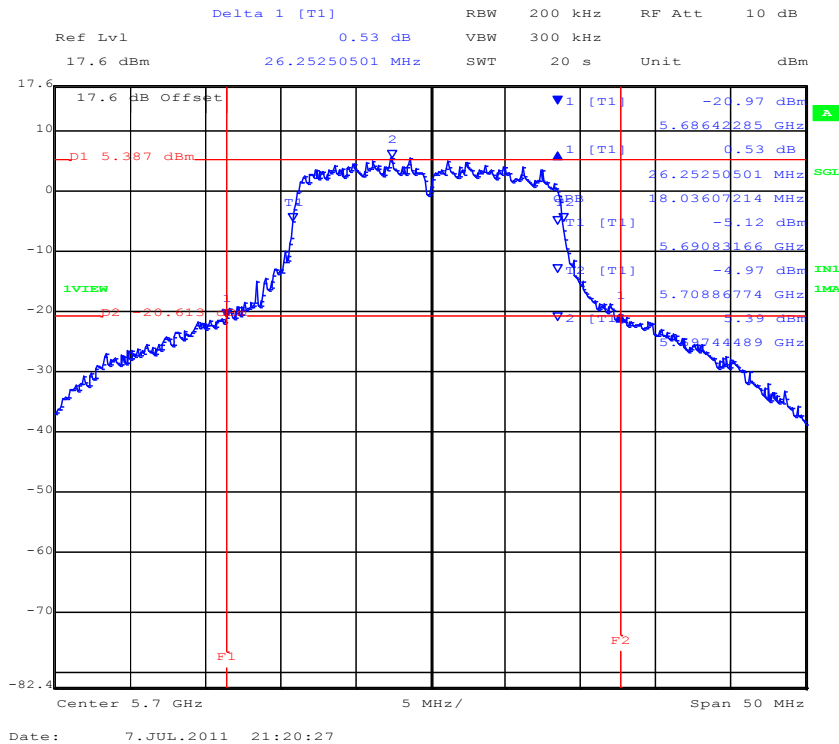

PORT B 5,700 MHz 802.11n HT-20 26 dB and 99 % Bandwidth

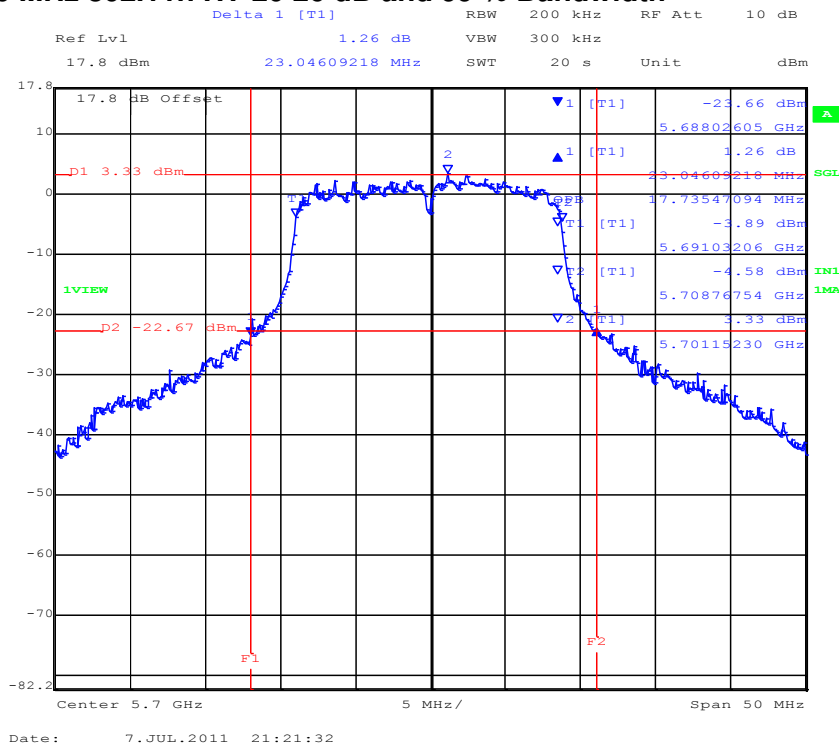

This test report may be reproduced in full only. The document may only be updated by MiCOM Labs personnel. Any changes will be noted in the Document History section of the report.



Title: NetScout Systems Inc. SENSOR4 Product Family
To: FCC 47 CFR Part 15.407 & IC RSS-247
Serial #: NTCT77-U3 Rev A
Issue Date: 12th December 2016
Page: 84 of 269

PORT C 5,700 MHz 802.11n HT-20 26 dB and 99 % Bandwidth

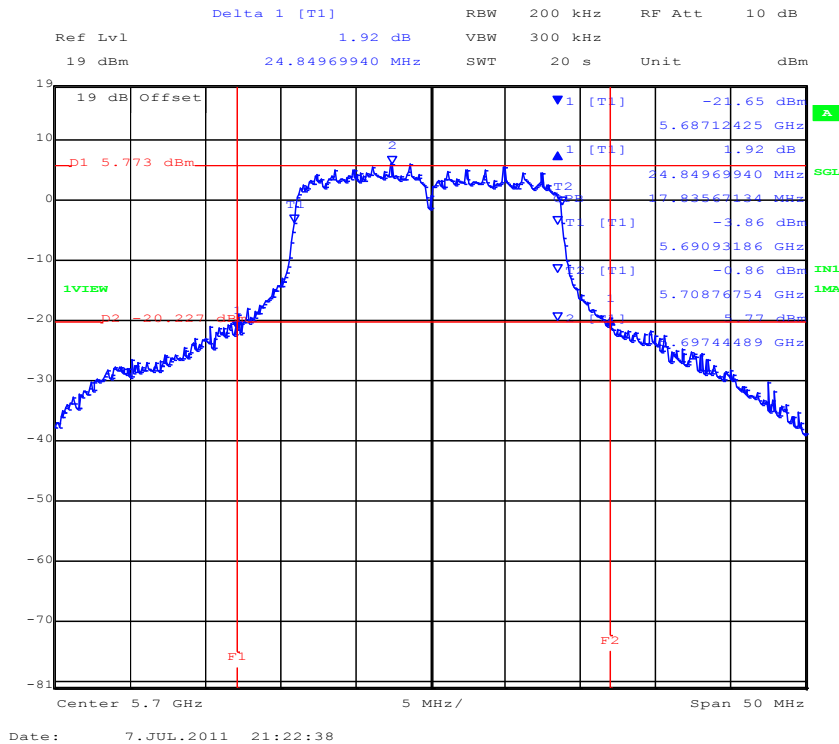

This test report may be reproduced in full only. The document may only be updated by MiCOM Labs personnel. Any changes will be noted in the Document History section of the report.



Title: NetScout Systems Inc. SENSOR4 Product Family
To: FCC 47 CFR Part 15.407 & IC RSS-247
Serial #: NTCT77-U3 Rev A
Issue Date: 12th December 2016
Page: 85 of 269

TABLE OF RESULTS – 802.11n HT-40 5500 – 5700 MHz

Test Conditions:	15.247 (a)(2)	Rel. Humidity (%):	35 to 42
Variant:	802.11n HT-40	Ambient Temp. (°C):	19 to 22
TPC:	HIGH	Pressure (mBars):	998 to 1003
Modulation:	ON	Duty Cycle (x):	100
Beam Forming Gain (Y):	N/A dB	Antenna Gain:	0 dBi
Applied Voltage:	48.0 Vdc		
Notes 1:			
Notes 2:			

26 dB Bandwidth

Test Frequency	26 dB Bandwidth				Minimum 6dB Bandwidth Limit		Margin
	MHz						
MHz	a	b	c	d	kHz	MHz	MHz
5510	45.892000	48.096000	42.285000		500	0.5	-41.785000
5550	47.896000	48.697000	45.892000				-45.392000
5670	49.900000	45.090000	47.094000				-44.590000

99% Bandwidth

Test Frequency	99 % Bandwidth					
	MHz					
MHz	a	b	c	d		
5510	36.473000	36.473000	36.273000			
5550	36.473000	36.473000	36.473000			
5670	36.473000	36.473000	36.473000			

Measurement uncertainty:	±2.81 dB
---------------------------------	----------

This test report may be reproduced in full only. The document may only be updated by MiCOM Labs personnel. Any changes will be noted in the Document History section of the report.



PORT A 5,510 MHz 802.11n HT-40 26 dB and 99 % Bandwidth

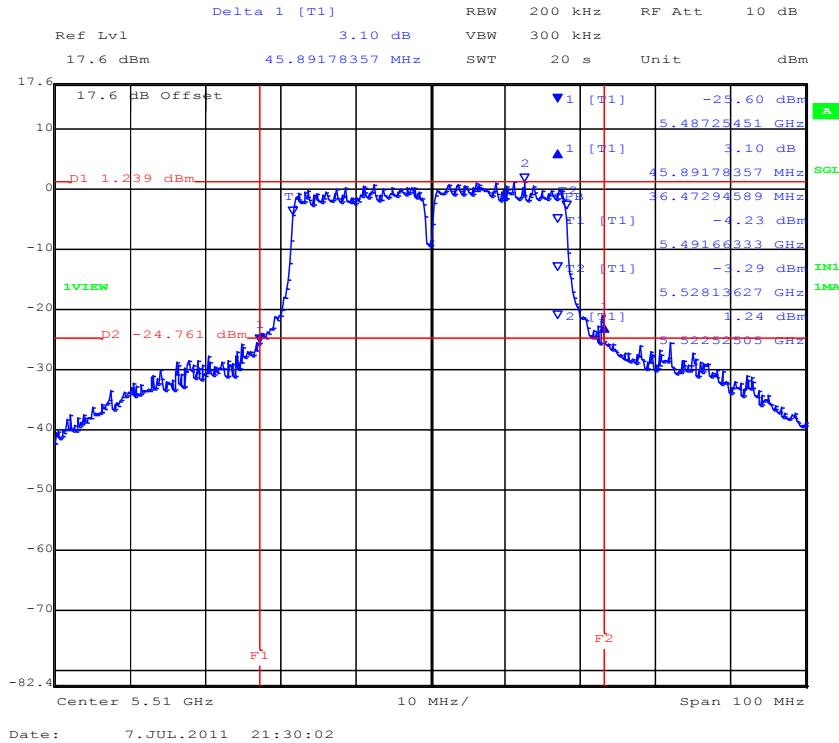

PORT B 5,510 MHz 802.11n HT-40 26 dB and 99 % Bandwidth

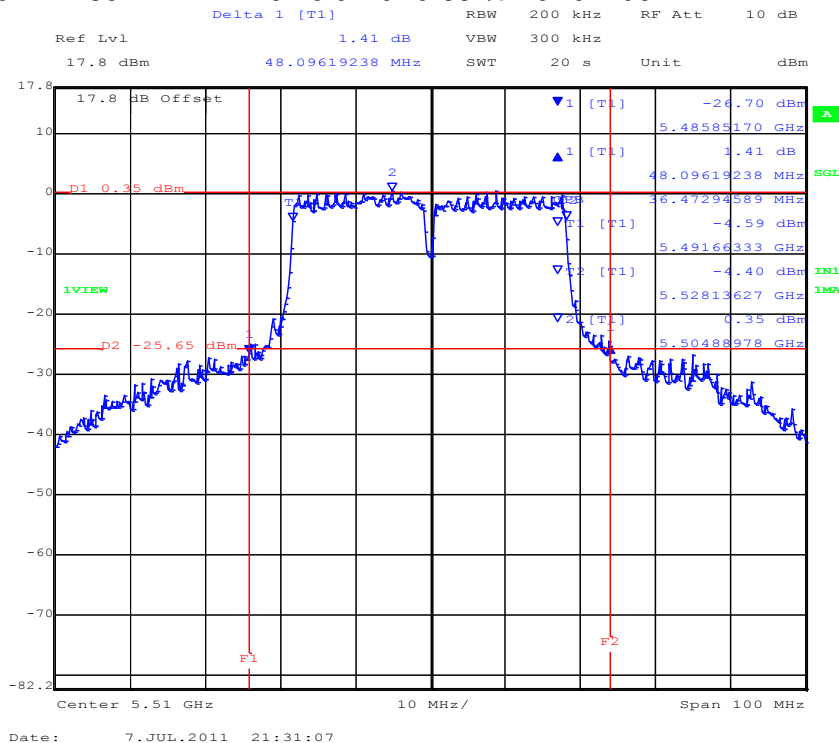

This test report may be reproduced in full only. The document may only be updated by MiCOM Labs personnel. Any changes will be noted in the Document History section of the report.



PORT C 5,510 MHz 802.11n HT-40 26 dB and 99 % Bandwidth

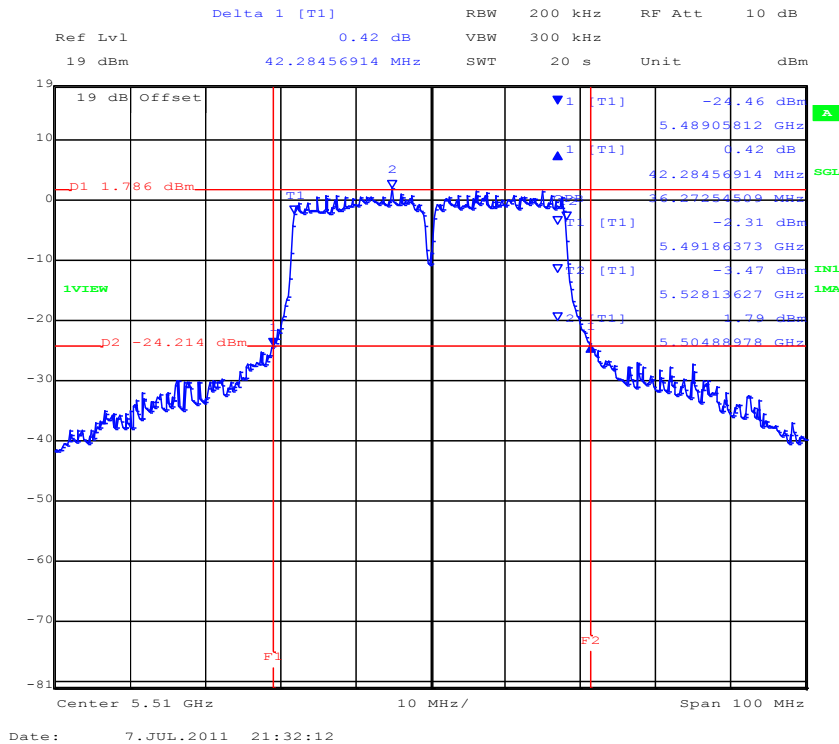

PORT A 5,550 MHz 802.11n HT-40 26 dB and 99 % Bandwidth

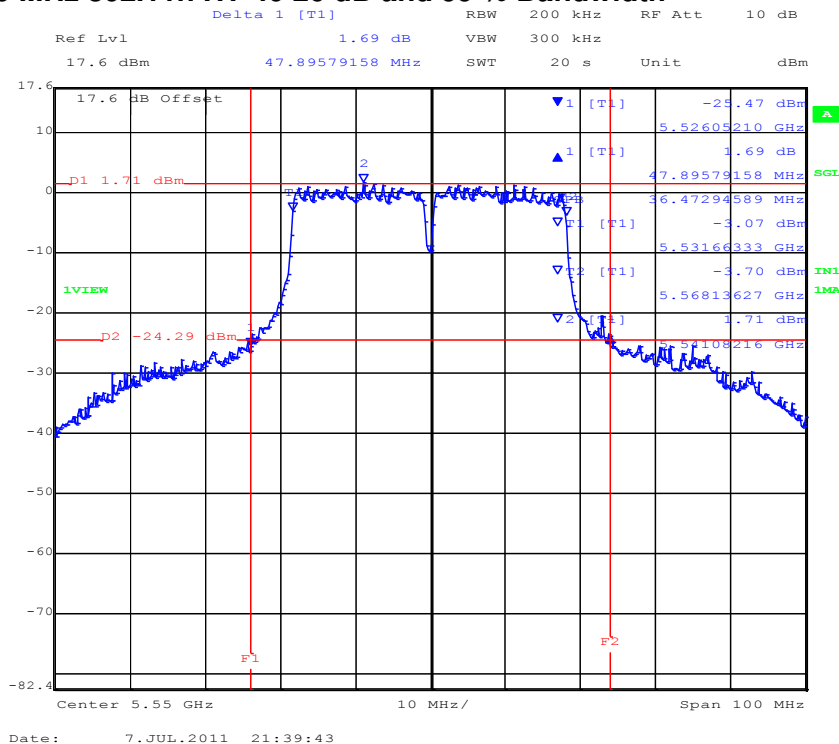

This test report may be reproduced in full only. The document may only be updated by MiCOM Labs personnel. Any changes will be noted in the Document History section of the report.



PORT B 5,550 MHz 802.11n HT-40 26 dB and 99 % Bandwidth

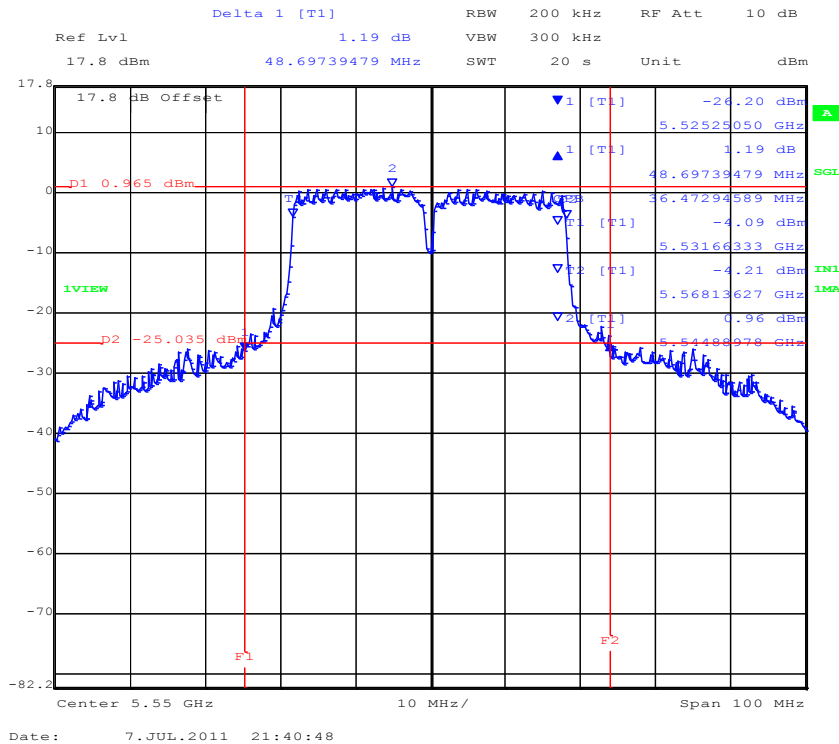

PORT C 5,550 MHz 802.11n HT-40 26 dB and 99 % Bandwidth

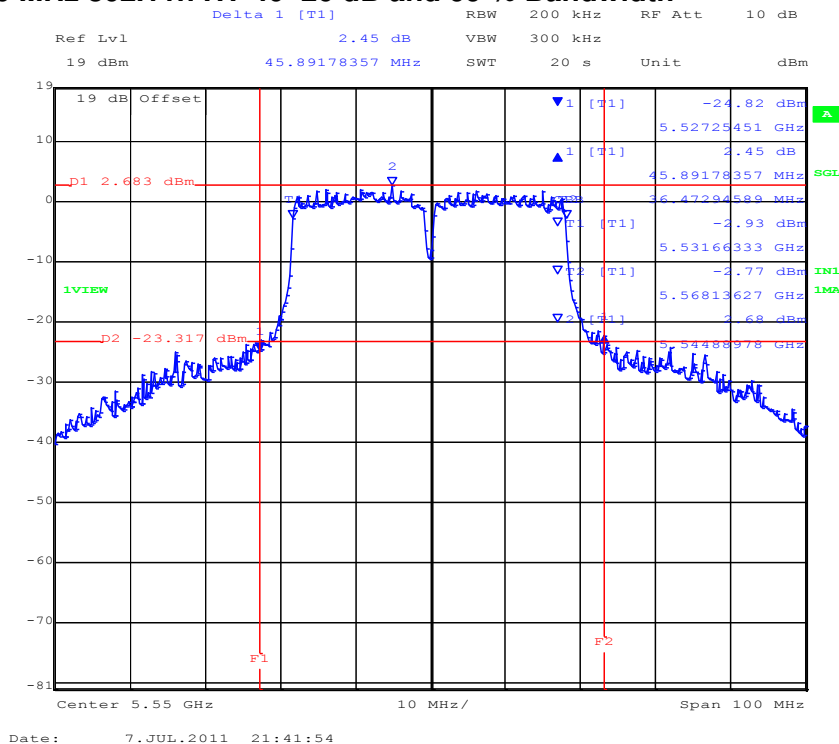

This test report may be reproduced in full only. The document may only be updated by MiCOM Labs personnel. Any changes will be noted in the Document History section of the report.



PORT A 5,670 MHz 802.11n HT-40 26 dB and 99 % Bandwidth

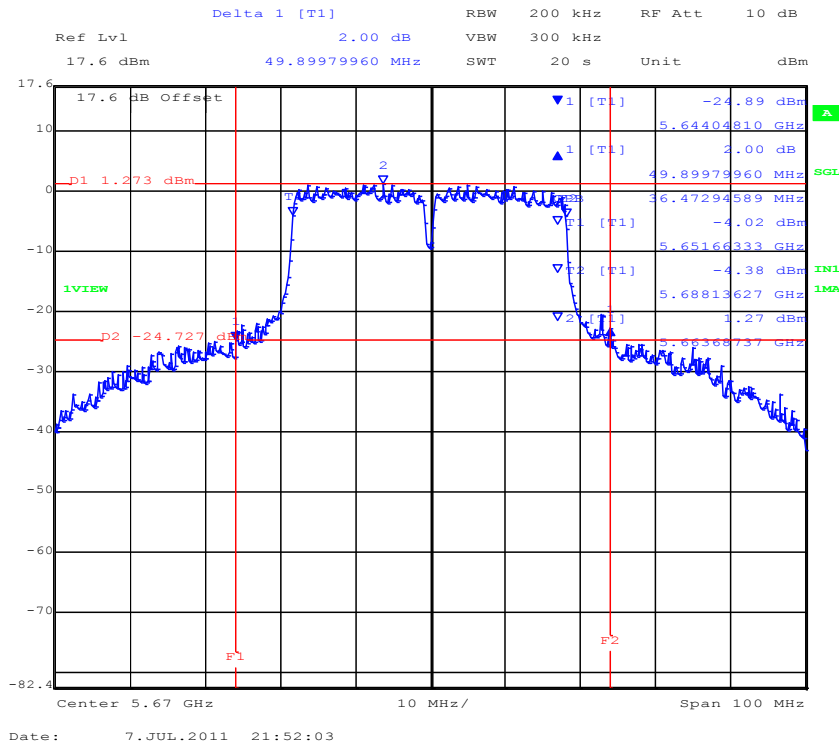

PORT B 5,670 MHz 802.11n HT-40 26 dB and 99 % Bandwidth

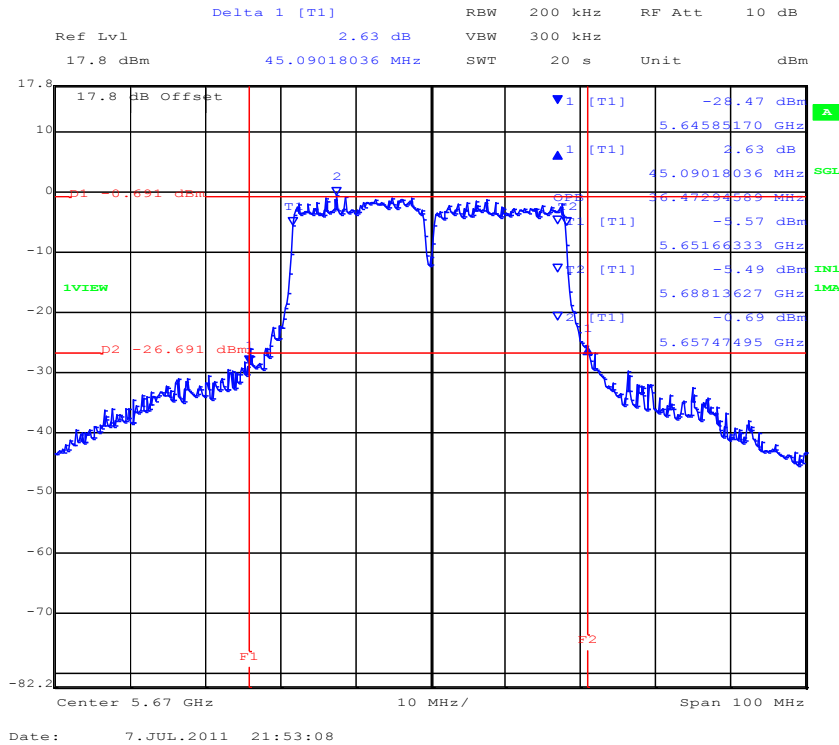

This test report may be reproduced in full only. The document may only be updated by MiCOM Labs personnel. Any changes will be noted in the Document History section of the report.



Title: NetScout Systems Inc. SENSOR4 Product Family
To: FCC 47 CFR Part 15.407 & IC RSS-247
Serial #: NTCT77-U3 Rev A
Issue Date: 12th December 2016
Page: 90 of 269

PORT C 5,670 MHz 802.11n HT-40 26 dB and 99 % Bandwidth

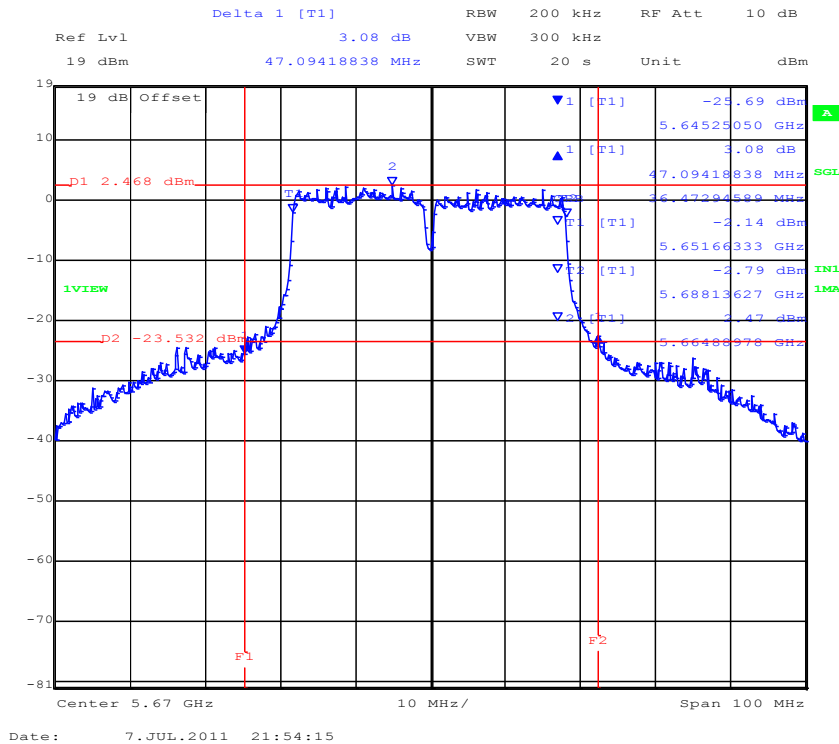

This test report may be reproduced in full only. The document may only be updated by MiCOM Labs personnel. Any changes will be noted in the Document History section of the report.



Title: NetScout Systems Inc. SENSOR4 Product Family
To: FCC 47 CFR Part 15.407 & IC RSS-247
Serial #: NTCT77-U3 Rev A
Issue Date: 12th December 2016
Page: 91 of 269

Laboratory Measurement Uncertainty for Spectrum Measurement

Measurement uncertainty	± 2.81 dB
-------------------------	---------------

This test report may be reproduced in full only. The document may only be updated by MiCOM Labs personnel. Any changes will be noted in the Document History section of the report.

5.1.2. Transmit Output Power

FCC, Part 15 Subpart C §15.407(a)
Industry Canada RSS-247 §6.2

Test Procedure

The transmitter terminal of EUT was connected to the input of an average power meter. Measurements were made while EUT was operating in a continuous transmission mode i.e. 100 % duty cycle at the appropriate center frequency. All cable losses and offsets were taken into consideration in the measured result.

Test Measurement Set up

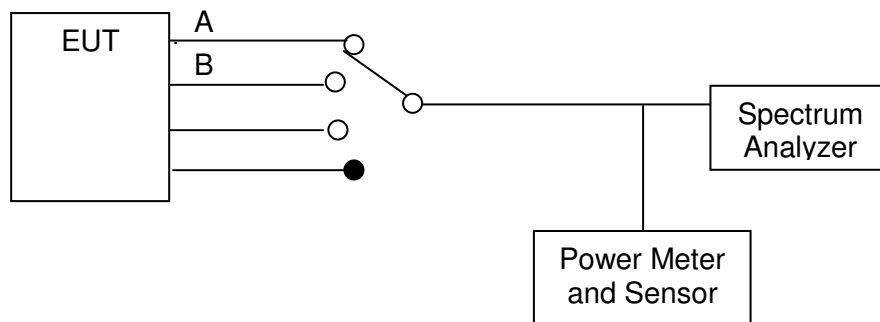

Measurement set up for Transmitter Output Power



Title: NetScout Systems Inc. SENSOR4 Product Family
To: FCC 47 CFR Part 15.407 & IC RSS-247
Serial #: NTCT77-U3 Rev A
Issue Date: 12th December 2016
Page: 93 of 269

Maximum Transmit (Conducted) Power, FCC Limits and Industry Canada Limits

Bands 5150 – 5250 MHz

FCC Limits

Conducted Power Limit lesser of: 50 mW or 4 dBm + 10 log (B) dBm

Mode	Frequency Range (MHz)	Minimum 26 dB Bandwidth (MHz)	4 + 10 Log (B) (dBm)	Limit (dBm)
a	5150 – 5250	22.3	+17.48	+17.00
HT-20		23.2	+17.65	+17.00
HT-40		43.5	+20.38	+17.00

Industry Canada Limits

EIRP Limit 5150 – 5250 MHz: Lesser of 200 mW (+23 dBm) or 10 + 10 Log (B) dBm

Mode	Frequency Range (MHz)	Minimum 26 dB Bandwidth (MHz)	4 + 10 Log (B) (dBm)	EIRP Limit (dBm)
a	5150 – 5250	22.3	+23.48	+23.00
HT-20		23.2	+23.65	+23.00
HT-40		43.5	+26.38	+23.00

FCC Limits and Industry Canada Limits

Bands 5250 – 5350 and 5470 – 5725 MHz

Limit lesser of: 250 mW or 11 dBm + 10 log (B) dBm

Mode	Frequency Range (MHz)	Minimum 26 dB Bandwidth (MHz)	11 + 10 Log (B) (dBm)	Limit (dBm)
a	5250 – 5350	26.0	+25.15	+24.00
HT-20		25.2	+25.01	+24.00
HT-40	5470 – 5725	45.9	+27.62	+24.00

This test report may be reproduced in full only. The document may only be updated by MiCOM Labs personnel. Any changes will be noted in the Document History section of the report.



Title: NetScout Systems Inc. SENSOR4 Product Family
To: FCC 47 CFR Part 15.407 & IC RSS-247
Serial #: NTCT77-U3 Rev A
Issue Date: 12th December 2016
Page: 94 of 269

Antenna Beam and Non-Beam Forming Power Levels

15. 407 (a)(1), (a) (2) Operation with directional antenna gains greater than 6 dBi.

If transmitting antennas of directional gain greater than 6 dBi are used, the conducted output power from the intentional radiator shall be reduced by the amount in dB that the directional gain of the antenna exceeds 6 dBi. Further FCC KDB 662911 D01 Multiple Transmitter Output v01 requires that the gain of antennas transmitting the same data (legacy 802.11a mode) must be increased by $10 * \text{Log}(N)$ when N is the number of antenna elements.

Operating Frequency Band 5150-5250 MHz

MIMO Operation

Antenna (dB)	Gain (dBi)	Max. Allowable Conducted Peak Power (dBm)		Maximum EIRP (dBm)
		Non-Beam Forming	Beam Forming	
Integral	4.8	+17.0	N/A	+23.0
External	2.0	+17.0		+23.0

Non-MIMO Operation (Legacy)

Antenna (dB)	Gain dBi	Increased Gain V's No. Antenna Ports		Total Gain dBi	Max. Allowable Conducted Peak Power (dBm)	Maximum EIRP (dBm)
		Ports	dB			
Integral	4.8	3	4.77	9.57	+13.43	+23.0
External	2.0	3	4.77	6.77	+16.23	+23.0

This test report may be reproduced in full only. The document may only be updated by MiCOM Labs personnel. Any changes will be noted in the Document History section of the report.



MIMO Operation 5250-5350 and 5470 – 5725 MHz

Antenna (dB)	Gain (dBi)	Max. Allowable Conducted Peak Power (dBm)		Maximum EIRP (dBm)
		Non-Beam Forming	Beam Forming	
Integral	4.8	+24.0	N/A	+30.0
External	2.0	+24.0		+30.0

Non-MIMO Operation (Legacy) 5250-5350 and 5470 – 5725 MHz

Antenna (dB)	Gain dBi	Increased Gain V's No. Antenna Ports		Total Gain dBi	Max. Allowable Conducted Peak Power (dBm)	Maximum EIRP (dBm)
		Ports	dB			
Integral	4.8	3	4.77	9.57	+20.43	+30.0
External	2.0	3	4.77	6.77	+23.23	+30.0

Measurement Results for Transmit Output Power

Ambient conditions.

Temperature: 17 to 23 °C Relative humidity: 31 to 57 % Pressure: 999 to 1012 mbar

EUT parameters.

Power Level: Maximum

Duty Cycle: 100%

Temperature: Ambient



TABLE OF RESULTS – 802.11a Legacy 5150 - 5250

Output Power Conditions for Integral Antenna

Test Conditions:	15.407 (a)(1)	Rel. Humidity (%):	35	to	42
Variant:	802.11 a	Ambient Temp. (°C):	19	to	22
TPC:	HIGH	Pressure (mBars):	998	to	1003
Modulation:	ON	Duty Cycle (x):	100		
Beam Forming Gain (Y):	N/A dB	Antenna Gain:	4.8 dBi		
Applied Voltage:	48.0 Vdc				
Notes 1:					
Notes 2:					

Test Frequency	Measured Peak Power				Total Power (dBm)		Limit	Margin
	RF Port (dBm)				Combined	Calculated		
MHz	a	b	c	d				
5180	8.97	7.18	9.11	--	N/A	13.28	13.43	-0.15
5200	9.39	7.63	8.76	--	N/A	13.42	13.43	-0.01
5240	9.00	6.94	8.53	--	N/A	13.01	13.43	-0.42

Measurement uncertainty:	±1.33 dB
---------------------------------	----------

Output Power Conditions for External Antenna

Test Conditions:	15.407 (a)(1)	Rel. Humidity (%):	35	to	42
Variant:	802.11 a	Ambient Temp. (°C):	19	to	22
TPC:	HIGH	Pressure (mBars):	998	to	1003
Modulation:	ON	Duty Cycle (x):	100		
Beam Forming Gain (Y):	N/A dB	Antenna Gain:	2 dBi		
Applied Voltage:	48.0 Vdc				
Notes 1:					
Notes 2:					

Test Frequency	Measured Peak Power				Total Power (dBm)		Limit	Margin
	RF Port (dBm)				Combined	Calculated		
MHz	a	b	c	d				
5180	11.52	9.61	11.64	--	N/A	15.79	16.23	-0.44
5200	11.39	9.93	10.96	--	N/A	15.57	16.23	-0.66
5240	12.00	9.94	11.53	--	N/A	16.01	16.23	-0.22

Measurement uncertainty:	±1.33 dB
---------------------------------	----------

This test report may be reproduced in full only. The document may only be updated by MiCOM Labs personnel. Any changes will be noted in the Document History section of the report.



TABLE OF RESULTS – 802.11n HT-20 5150 - 5250

Output Power Conditions for Integral Antenna

Test Conditions:	15.407 (a)(1)	Rel. Humidity (%):	35	to	42
Variant:	802.11 n HT-20	Ambient Temp. (°C):	19	to	22
TPC:	HIGH	Pressure (mBars):	998	to	1003
Modulation:	ON	Duty Cycle (x):	100		
Beam Forming Gain (Y):	N/A dB	Antenna Gain:	4.8 dBi		
Applied Voltage:	48.0 Vdc				
Notes 1:					
Notes 2:					

Test Frequency	Measured Peak Power				Total Power (dBm)		Limit	Margin
	RF Port (dBm)				Combined	Calculated		
MHz	a	b	c	d				
5180	12.41	10.70	13.01	--	N/A	16.92	17.00	-0.08
5200	12.42	11.33	12.49	--	N/A	16.88	17.00	-0.12
5240	12.49	11.04	12.17	--	N/A	16.71	17.00	-0.29

Measurement uncertainty:	±1.33 dB
---------------------------------	----------

Output Power Conditions for External Antenna

Test Conditions:	15.407 (a)(1)	Rel. Humidity (%):	35	to	42
Variant:	802.11 n HT-20	Ambient Temp. (°C):	19	to	22
TPC:	HIGH	Pressure (mBars):	998	to	1003
Modulation:	ON	Duty Cycle (x):	100		
Beam Forming Gain (Y):	N/A dB	Antenna Gain:	2 dBi		
Applied Voltage:	48.0 Vdc				
Notes 1:					
Notes 2:					

Test Frequency	Measured Peak Power				Total Power (dBm)		Limit	Margin
	RF Port (dBm)				Combined	Calculated		
MHz	a	b	c	d				
5180	12.59	11.30	12.10	--	N/A	16.80	17.00	-0.20
5200	12.23	11.39	12.71	--	N/A	16.91	17.00	-0.09
5240	12.35	11.44	12.34	--	N/A	16.83	17.00	-0.17

Measurement uncertainty:	±1.33 dB
---------------------------------	----------

This test report may be reproduced in full only. The document may only be updated by MiCOM Labs personnel. Any changes will be noted in the Document History section of the report.



TABLE OF RESULTS – 802.11n HT-40 5150 - 5250

Output Power Conditions for Integral Antenna

Test Conditions:	15.407 (a)(1)	Rel. Humidity (%):	35	to	42
Variant:	802.11 n HT-40	Ambient Temp. (°C):	19	to	22
TPC:	HIGH	Pressure (mBars):	998	to	1003
Modulation:	ON	Duty Cycle (x):	100		
Beam Forming Gain (Y):	N/A dB	Antenna Gain:	4.8 dBi		
Applied Voltage:	48.0 Vdc				
Notes 1:					
Notes 2:					

Test Frequency	Measured Peak Power				Total Power (dBm)		Limit	Margin
	RF Port (dBm)				Combined	Calculated		
MHz	a	b	c	d				
5190	11.01	8.21	11.73	--	N/A	15.33	17.00	-1.67
5230	12.55	11.67	11.78	--	N/A	16.79	17.00	-0.21

Measurement uncertainty:	±1.33 dB
---------------------------------	----------

Output Power Conditions for External Antenna

Test Conditions:	15.407 (a)(1)	Rel. Humidity (%):	35	to	42
Variant:	802.11 n HT-40	Ambient Temp. (°C):	19	to	22
TPC:	HIGH	Pressure (mBars):	998	to	1003
Modulation:	ON	Duty Cycle (x):	100		
Beam Forming Gain (Y):	N/A dB	Antenna Gain:	2 dBi		
Applied Voltage:	48.0 Vdc				
Notes 1:					
Notes 2:					

Test Frequency	Measured Peak Power				Total Power (dBm)		Limit	Margin
	RF Port (dBm)				Combined	Calculated		
MHz	a	b	c	d				
5190	11.97	9.31	12.57	--	N/A	16.27	17.00	-0.73
5230	12.69	11.57	12.15	--	N/A	16.93	17.00	-0.07

Measurement uncertainty:	±1.33 dB
---------------------------------	----------

This test report may be reproduced in full only. The document may only be updated by MiCOM Labs personnel. Any changes will be noted in the Document History section of the report.



TABLE OF RESULTS – 802.11a Legacy 5250 - 5350

Output Power Conditions for Integral Antenna

Test Conditions:	15.407 (a)(1)	Rel. Humidity (%):	35	to	42
Variant:	802.11 a	Ambient Temp. (°C):	19	to	22
TPC:	HIGH	Pressure (mBars):	998	to	1003
Modulation:	ON	Duty Cycle (x):	100		
Beam Forming Gain (Y):	N/A dB	Antenna Gain:	4.8 dBi		
Applied Voltage:	48.0 Vdc				
Notes 1:					
Notes 2:					

Test Frequency	Measured Peak Power				Total Power (dBm)		Limit	Margin
	RF Port (dBm)				Combined	Calculated		
MHz	a	b	c	d				
5260	15.87	14.65	15.50	--	N/A	20.14	20.43	-0.29
5300	16.18	14.19	14.49	--	N/A	19.82	20.43	-0.61
5320	15.52	13.97	14.62	--	N/A	19.52	20.43	-0.91

Measurement uncertainty:	±1.33 dB
---------------------------------	----------

Output Power Conditions for External Antenna

Test Conditions:	15.407 (a)(1)	Rel. Humidity (%):	35	to	42
Variant:	802.11 a	Ambient Temp. (°C):	19	to	22
TPC:	HIGH	Pressure (mBars):	998	to	1003
Modulation:	ON	Duty Cycle (x):	100		
Beam Forming Gain (Y):	N/A dB	Antenna Gain:	2 dBi		
Applied Voltage:	48.0 Vdc				
Notes 1:					
Notes 2:					

Test Frequency	Measured Peak Power				Total Power (dBm)		Limit	Margin
	RF Port (dBm)				Combined	Calculated		
MHz	a	b	c	d				
5260	18.87	17.65	18.50	--	N/A	23.14	23.23	-0.09
5300	19.18	17.19	17.49	--	N/A	22.82	23.23	-0.41
5320	17.31	15.76	16.71	--	N/A	21.41	23.23	-1.82

Measurement uncertainty:	±1.33 dB
---------------------------------	----------

This test report may be reproduced in full only. The document may only be updated by MiCOM Labs personnel. Any changes will be noted in the Document History section of the report.



TABLE OF RESULTS – 802.11n HT-20 5250 - 5350

Output Power Conditions for Integral Antenna

Test Conditions:	15.407 (a)(1)	Rel. Humidity (%):	35	to	42
Variant:	802.11 n HT-20	Ambient Temp. (°C):	19	to	22
TPC:	HIGH	Pressure (mBars):	998	to	1003
Modulation:	ON	Duty Cycle (x):	100		
Beam Forming Gain (Y):	N/A dB	Antenna Gain:	4.8 dBi		
Applied Voltage:	48.0 Vdc				
Notes 1:					
Notes 2:					

Test Frequency	Measured Peak Power				Total Power (dBm)		Limit	Margin
	RF Port (dBm)				Combined	Calculated		
MHz	a	b	c	d				
5260	18.67	17.55	18.39	--	N/A	23.00	24.00	-1.00
5300	18.92	17.26	17.77	--	N/A	22.81	24.00	-1.19
5320	15.62	13.43	14.42	--	N/A	19.35	24.00	-4.65

Measurement uncertainty:	±1.33 dB
---------------------------------	----------

Output Power Conditions for External Antenna

Test Conditions:	15.407 (a)(1)	Rel. Humidity (%):	35	to	42
Variant:	802.11 n HT-20	Ambient Temp. (°C):	19	to	22
TPC:	HIGH	Pressure (mBars):	998	to	1003
Modulation:	ON	Duty Cycle (x):	100		
Beam Forming Gain (Y):	N/A dB	Antenna Gain:	2 dBi		
Applied Voltage:	48.0 Vdc				
Notes 1:					
Notes 2:					

Test Frequency	Measured Peak Power				Total Power (dBm)		Limit	Margin
	RF Port (dBm)				Combined	Calculated		
MHz	a	b	c	d				
5260	18.67	17.55	18.39	--	N/A	23.00	24.00	-1.00
5300	18.92	17.26	17.77	--	N/A	22.81	24.00	-1.19
5320	17.53	15.11	16.87	--	N/A	21.39	24.00	-2.61

Measurement uncertainty:	±1.33 dB
---------------------------------	----------

This test report may be reproduced in full only. The document may only be updated by MiCOM Labs personnel. Any changes will be noted in the Document History section of the report.



TABLE OF RESULTS – 802.11n HT-40 5250 - 5350

Output Power Conditions for Integral Antenna

Test Conditions:	15.407 (a)(1)	Rel. Humidity (%):	35	to	42
Variant:	802.11 n HT-40	Ambient Temp. (°C):	19	to	22
TPC:	HIGH	Pressure (mBars):	998	to	1003
Modulation:	ON	Duty Cycle (x):	100		
Beam Forming Gain (Y):	N/A dB	Antenna Gain:	4.8 dBi		
Applied Voltage:	48.0 Vdc				
Notes 1:					
Notes 2:					

Test Frequency	Measured Peak Power				Total Power (dBm)		Limit	Margin
	RF Port (dBm)				Combined	Calculated		
MHz	a	b	c	d				
5270	19.06	17.35	18.16	--	N/A	23.02	24.00	-0.98
5310	13.46	10.14	11.18	--	N/A	16.59	24.00	-7.41

Measurement uncertainty:	±1.33 dB
---------------------------------	----------

Output Power Conditions for External Antenna

Test Conditions:	15.407 (a)(1)	Rel. Humidity (%):	35	to	42
Variant:	802.11 n HT-40	Ambient Temp. (°C):	19	to	22
TPC:	HIGH	Pressure (mBars):	998	to	1003
Modulation:	ON	Duty Cycle (x):	100		
Beam Forming Gain (Y):	N/A dB	Antenna Gain:	2 dBi		
Applied Voltage:	48.0 Vdc				
Notes 1:					
Notes 2:					

Test Frequency	Measured Peak Power				Total Power (dBm)		Limit	Margin
	RF Port (dBm)				Combined	Calculated		
MHz	a	b	c	d				
5270	19.06	17.35	18.16	--	N/A	23.02	24.00	-0.98
5310	14.66	10.74	12.98	--	N/A	17.85	24.00	-6.15

Measurement uncertainty:	±1.33 dB
---------------------------------	----------

This test report may be reproduced in full only. The document may only be updated by MiCOM Labs personnel. Any changes will be noted in the Document History section of the report.



TABLE OF RESULTS – 802.11a Legacy 5470 - 5725

Output Power Conditions for Integral Antenna

Test Conditions:	15.407 (a)(1)	Rel. Humidity (%):	35	to	42
Variant:	802.11 a	Ambient Temp. (°C):	19	to	22
TPC:	HIGH	Pressure (mBars):	998	to	1003
Modulation:	ON	Duty Cycle (x):	100		
Beam Forming Gain (Y):	N/A dB	Antenna Gain:	4.8 dBi		
Applied Voltage:	48.0 Vdc				
Notes 1:					
Notes 2:					

Test Frequency	Measured Peak Power				Total Power (dBm)		Limit	Margin
	RF Port (dBm)				Combined	Calculated		
MHz	a	b	c	d				
5500	16.32	13.84	14.52	--	N/A	19.79	20.43	-0.64
5580	16.55	14.35	15.01	--	N/A	20.17	20.43	-0.26
5700	16.01	14.16	14.24	--	N/A	19.66	20.43	-0.77

Measurement uncertainty:	±1.33 dB
---------------------------------	----------

Output Power Conditions for External Antenna

Test Conditions:	15.407 (a)(1)	Rel. Humidity (%):	35	to	42
Variant:	802.11 a	Ambient Temp. (°C):	19	to	22
TPC:	HIGH	Pressure (mBars):	998	to	1003
Modulation:	ON	Duty Cycle (x):	100		
Beam Forming Gain (Y):	N/A dB	Antenna Gain:	2 dBi		
Applied Voltage:	48.0 Vdc				
Notes 1:					
Notes 2:					

Test Frequency	Measured Peak Power				Total Power (dBm)		Limit	Margin
	RF Port (dBm)				Combined	Calculated		
MHz	a	b	c	d				
5500	18.32	15.84	16.52	--	N/A	21.79	23.23	-1.44
5580	18.55	16.35	17.01	--	N/A	22.17	23.23	-1.06
5700	19.01	17.16	17.24	--	N/A	22.66	23.23	-0.57

Measurement uncertainty:	±1.33 dB
---------------------------------	----------

This test report may be reproduced in full only. The document may only be updated by MiCOM Labs personnel. Any changes will be noted in the Document History section of the report.



TABLE OF RESULTS – 802.11n HT-20 5470 - 5725

Output Power Conditions for Integral Antenna

Test Conditions:	15.407 (a)(1)	Rel. Humidity (%):	35	to	42
Variant:	802.11 n HT-20	Ambient Temp. (°C):	19	to	22
TPC:	HIGH	Pressure (mBars):	998	to	1003
Modulation:	ON	Duty Cycle (x):	100		
Beam Forming Gain (Y):	N/A dB	Antenna Gain:	4.8 dBi		
Applied Voltage:	48.0 Vdc				
Notes 1:					
Notes 2:					

Test Frequency	Measured Peak Power				Total Power (dBm)		Limit	Margin
	RF Port (dBm)				Combined	Calculated		
MHz	a	b	c	d				
5500	18.13	16.01	16.42	--	N/A	21.73	24.00	-2.27
5580	18.30	16.34	17.02	--	N/A	22.07	24.00	-1.93
5700	19.25	17.18	17.06	--	N/A	22.72	24.00	-1.28

Measurement uncertainty:	±1.33 dB
---------------------------------	----------

Output Power Conditions for External Antenna

Test Conditions:	15.407 (a)(1)	Rel. Humidity (%):	35	to	42
Variant:	802.11 n HT-20	Ambient Temp. (°C):	19	to	22
TPC:	HIGH	Pressure (mBars):	998	to	1003
Modulation:	ON	Duty Cycle (x):	100		
Beam Forming Gain (Y):	N/A dB	Antenna Gain:	2 dBi		
Applied Voltage:	48.0 Vdc				
Notes 1:					
Notes 2:					

Test Frequency	Measured Peak Power				Total Power (dBm)		Limit	Margin
	RF Port (dBm)				Combined	Calculated		
MHz	a	b	c	d				
5500	18.13	16.01	16.42	--	N/A	21.73	24.00	-2.27
5580	18.30	16.34	17.02	--	N/A	22.07	24.00	-1.93
5700	19.25	17.18	17.06	--	N/A	22.72	24.00	-1.28

Measurement uncertainty:	±1.33 dB
---------------------------------	----------

This test report may be reproduced in full only. The document may only be updated by MiCOM Labs personnel. Any changes will be noted in the Document History section of the report.



TABLE OF RESULTS – 802.11n HT-40 5470 - 5725

Output Power Conditions for Integral Antenna

Test Conditions:	15.407 (a)(1)	Rel. Humidity (%):	35	to	42
Variant:	802.11 n HT-40	Ambient Temp. (°C):	19	to	22
TPC:	HIGH	Pressure (mBars):	998	to	1003
Modulation:	ON	Duty Cycle (x):	100		
Beam Forming Gain (Y):	N/A dB	Antenna Gain:	4.8 dBi		
Applied Voltage:	48.0 Vdc				
Notes 1:					
Notes 2:					

Test Frequency	Measured Peak Power				Total Power (dBm)		Limit	Margin
	RF Port (dBm)				Combined	Calculated		
MHz	a	b	c	d				
5500	17.16	13.75	13.88	--	N/A	20.01	24.00	-3.99
5580	19.09	16.28	17.06	--	N/A	22.41	24.00	-1.59
5700	19.25	16.99	16.97	--	N/A	22.65	24.00	-1.35

Measurement uncertainty:	±1.33 dB
---------------------------------	----------

Output Power Conditions for External Antenna

Test Conditions:	15.407 (a)(1)	Rel. Humidity (%):	35	to	42
Variant:	802.11 n HT-40	Ambient Temp. (°C):	19	to	22
TPC:	HIGH	Pressure (mBars):	998	to	1003
Modulation:	ON	Duty Cycle (x):	100		
Beam Forming Gain (Y):	N/A dB	Antenna Gain:	2 dBi		
Applied Voltage:	48.0 Vdc				
Notes 1:					
Notes 2:					

Test Frequency	Measured Peak Power				Total Power (dBm)		Limit	Margin
	RF Port (dBm)				Combined	Calculated		
MHz	a	b	c	d				
5500	19.31	15.96	16.04	--	N/A	22.17	24.00	-1.83
5580	19.09	16.28	17.06	--	N/A	22.41	24.00	-1.59
5700	19.25	16.99	16.97	--	N/A	22.65	24.00	-1.35

Measurement uncertainty:	±1.33 dB
---------------------------------	----------

This test report may be reproduced in full only. The document may only be updated by MiCOM Labs personnel. Any changes will be noted in the Document History section of the report.



Power Settings V's Frequency Band

Frequency Band 5150 – 5250 MHz

	Integral Antenna			External Antenna	
	a	HT-20		a	HT-20
5180	8	13		11	16
5200	10	15		12	17
5240	10	15		13	17

	HT-40			HT-40	
5190		10			11
5230		14			17

Frequency Band 5250 – 5350 MHz

	Integral Antenna			External Antenna	
	a	HT-20		a	HT-20
5260	17	20		20	20
5300	17	20		20	20
5240	19	16		18	18

	HT-40			HT-40	
5270		20			20
5310		13			13

Frequency Band 5470 – 5725 MHz

	Integral Antenna			External Antenna	
	a	HT-20		a	HT-20
5500	18	20		20	20
5580	18	20		20	20
5700	17	20		20	20

	HT-40			HT-40	
5510		17			20
5550		20			20
5670		20			20



Title: NetScout Systems Inc. SENSOR4 Product Family
To: FCC 47 CFR Part 15.407 & IC RSS-247
Serial #: NTCT77-U3 Rev A
Issue Date: 12th December 2016
Page: 106 of 269

Laboratory Measurement Uncertainty for Power Measurements

Measurement uncertainty	± 1.33 dB
-------------------------	---------------

This test report may be reproduced in full only. The document may only be updated by MiCOM Labs personnel. Any changes will be noted in the Document History section of the report.

5.1.3. Peak Power Spectral Density

FCC, Part 15 Subpart C §15.407(a)
Industry Canada RSS-247 § 6.2

Test Procedure

The transmitter output was connected to a spectrum analyzer and the peak power spectral density measured. Method 2 Sample Detection and power averaging, specified in FCC document DA 02-2138 (Normative Reference (ix) Section 2.1 “Guidelines for Assessing Unlicensed National Information Infrastructure (U-NII) Devices”) was used to determine the peak power spectral density of the emission. The Peak Power Spectral Density is the highest level found across the emission in a 1 MHz resolution bandwidth.

Test Measurement Set up

Test Measurement Set up

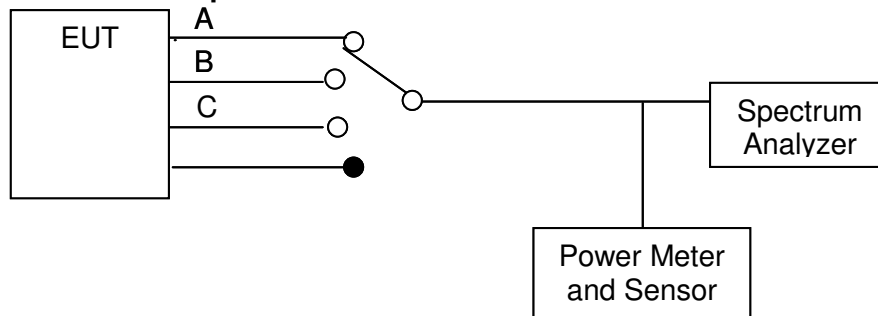

Measurement set up for Peak Power Spectral Density

Measurement Results for Peak Power Spectral Density

Ambient conditions.

Temperature: 17 to 23 °C Relative humidity: 31 to 57 % Pressure: 999 to 1012 mbar

Radio Parameters

Duty Cycle: 100%

Output: Modulated Carrier

Power: Maximum Default Power

This test report may be reproduced in full only. The document may only be updated by MiCOM Labs personnel. Any changes will be noted in the Document History section of the report.



Title: NetScout Systems Inc. SENSOR4 Product Family
To: FCC 47 CFR Part 15.407 & IC RSS-247
Serial #: NTCT77-U3 Rev A
Issue Date: 12th December 2016
Page: 108 of 269

TABLE OF RESULTS – 802.11a Legacy 5150 – 5250 MHz

Test Conditions:	15.407 (a)	Rel. Humidity (%):	35	to	42
Variant:	802.11a	Ambient Temp. (°C):	19	to	22
TPC:	HIGH	Pressure (mBars):	998	to	1003
Modulation:	ON	Duty Cycle (%):	100		
Beam Forming Gain (Y):	N/A dB	Antenna Gain:	0 dBi		
Applied Voltage:	48.0 Vdc	Antenna Ports (N):	3		
Notes 1:					
Notes 2:					

Test Frequency	Measured Peak Power				Correction factor	Peak Power Spectral Density	Limit	Margin
	RF Port (dBm)							
MHz	a	b	c	d	10Log(N)	dBm	dBm	dB
5180.00	-5.37	-4.52	-7.77	--	4.77	0.25	4.00	-3.75
5200.00	-4.83	-3.89	-8.02	--	4.77	0.89	4.00	-3.11
5240.00	-4.96	-4.91	-8.22	--	4.77	-0.14	4.00	-4.14

Measurement uncertainty:	±1.33 dB
---------------------------------	----------

This test report may be reproduced in full only. The document may only be updated by MiCOM Labs personnel. Any changes will be noted in the Document History section of the report.



PORT A 5,1800 MHz 802.11a Legacy Power Spectral Density

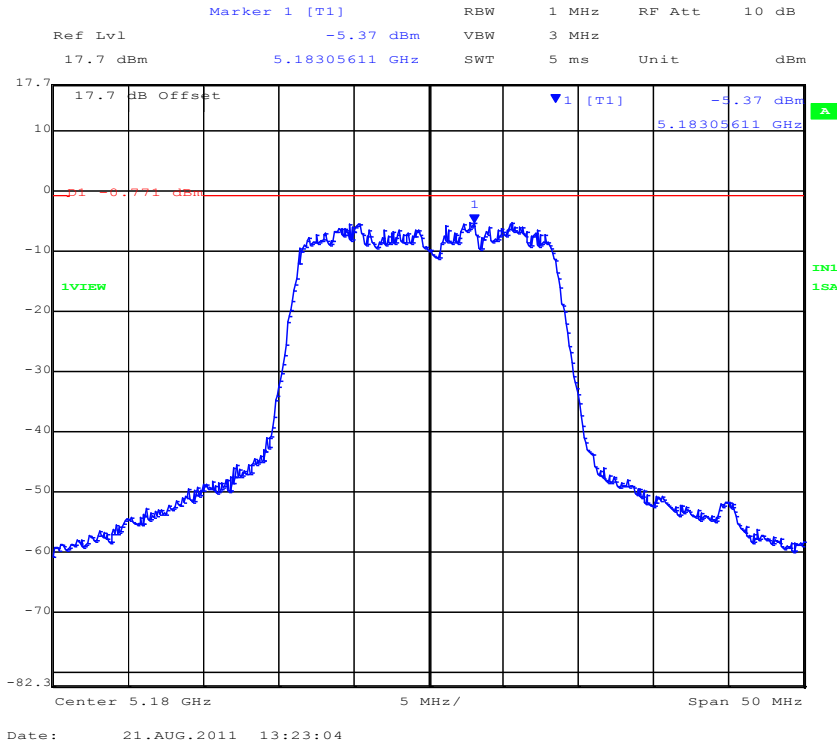

PORT B 5,1800 MHz 802.11a Legacy Power Spectral Density

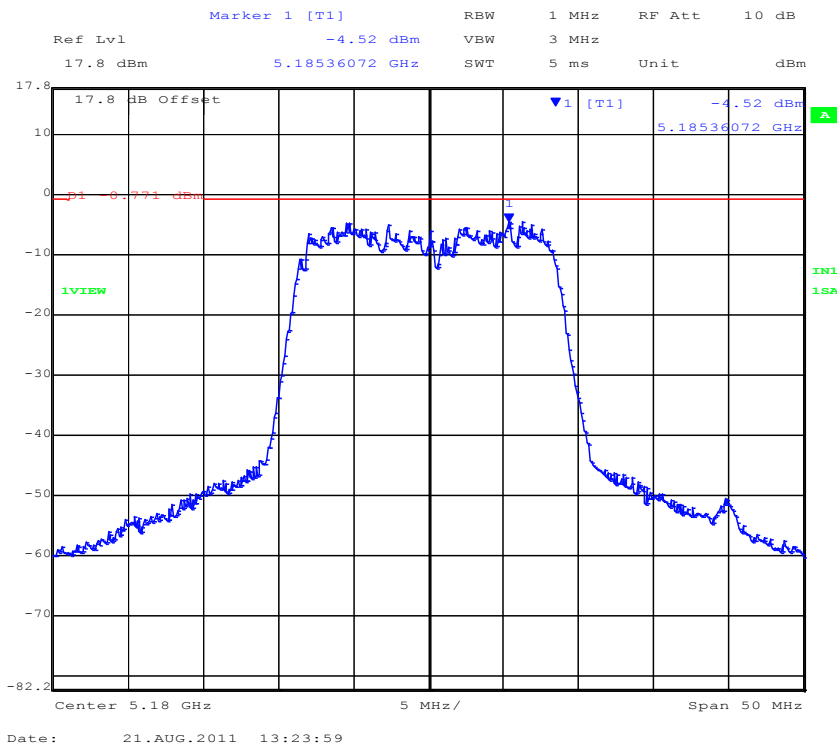

This test report may be reproduced in full only. The document may only be updated by MiCOM Labs personnel. Any changes will be noted in the Document History section of the report.



Title: NetScout Systems Inc. SENSOR4 Product Family
To: FCC 47 CFR Part 15.407 & IC RSS-247
Serial #: NTCT77-U3 Rev A
Issue Date: 12th December 2016
Page: 111 of 269

PORT A 5,200 MHz 802.11a Legacy Power Spectral Density

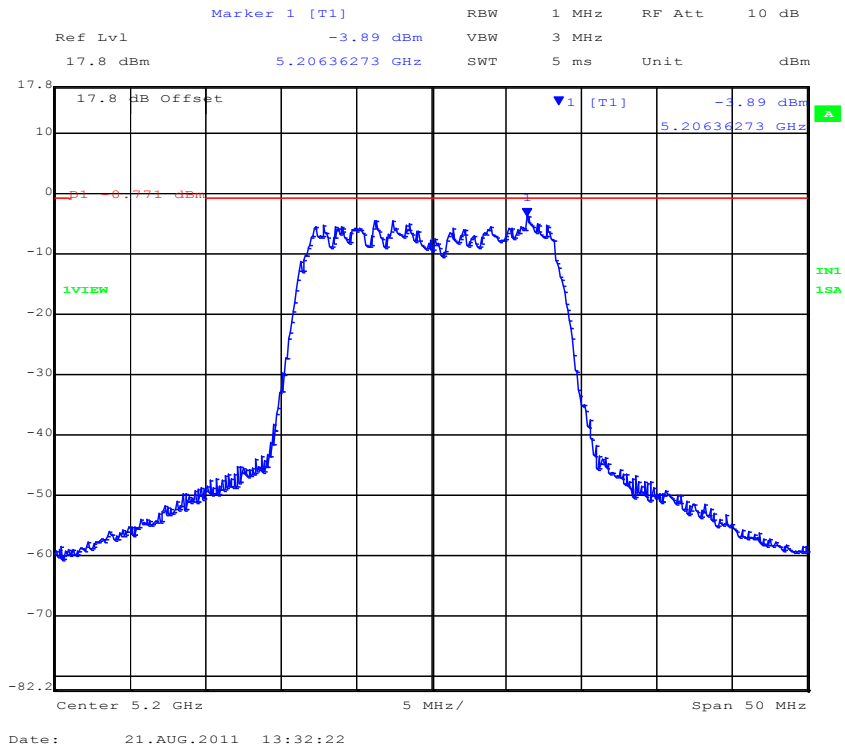

PORT B 5,200 MHz 802.11a Legacy Power Spectral Density

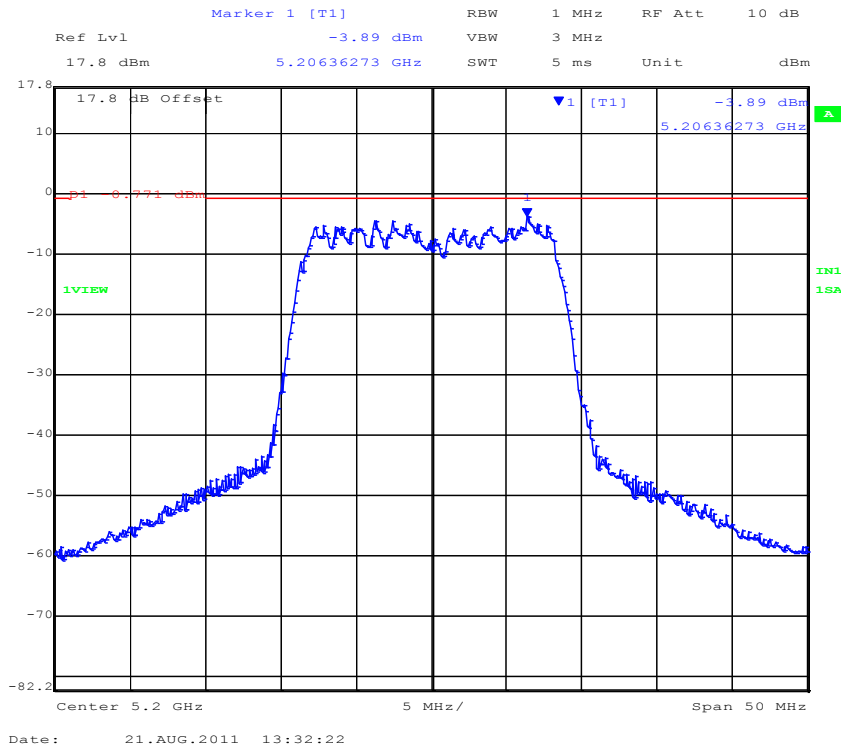

This test report may be reproduced in full only. The document may only be updated by MiCOM Labs personnel. Any changes will be noted in the Document History section of the report.



Title: NetScout Systems Inc. SENSOR4 Product Family
To: FCC 47 CFR Part 15.407 & IC RSS-247
Serial #: NTCT77-U3 Rev A
Issue Date: 12th December 2016
Page: 112 of 269

PORT C 5,200 MHz 802.11a Legacy Power Spectral Density

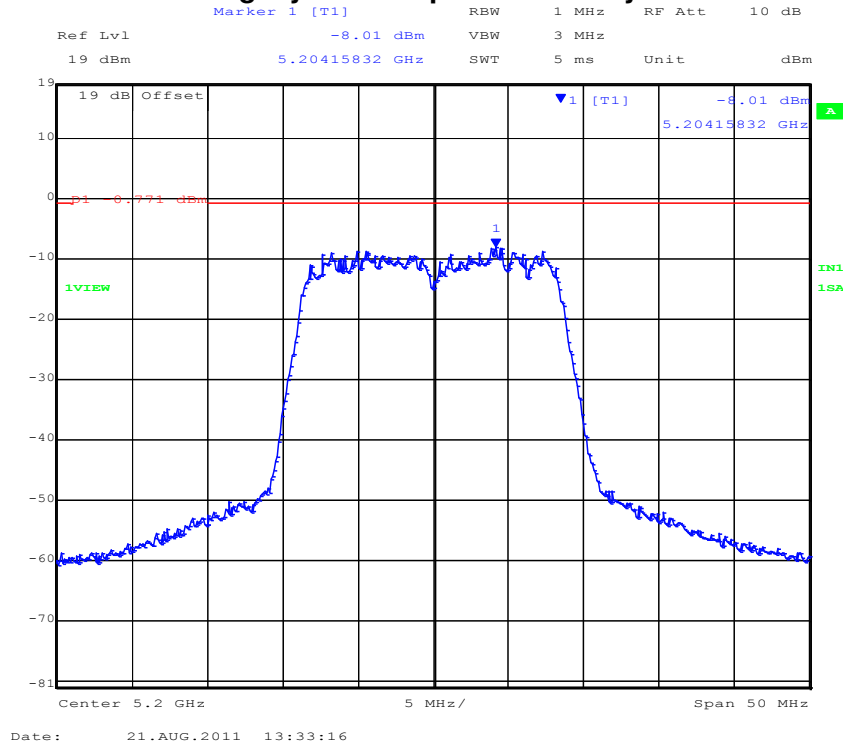

This test report may be reproduced in full only. The document may only be updated by MiCOM Labs personnel. Any changes will be noted in the Document History section of the report.



PORT A 5,240 MHz 802.11a Legacy Power Spectral Density

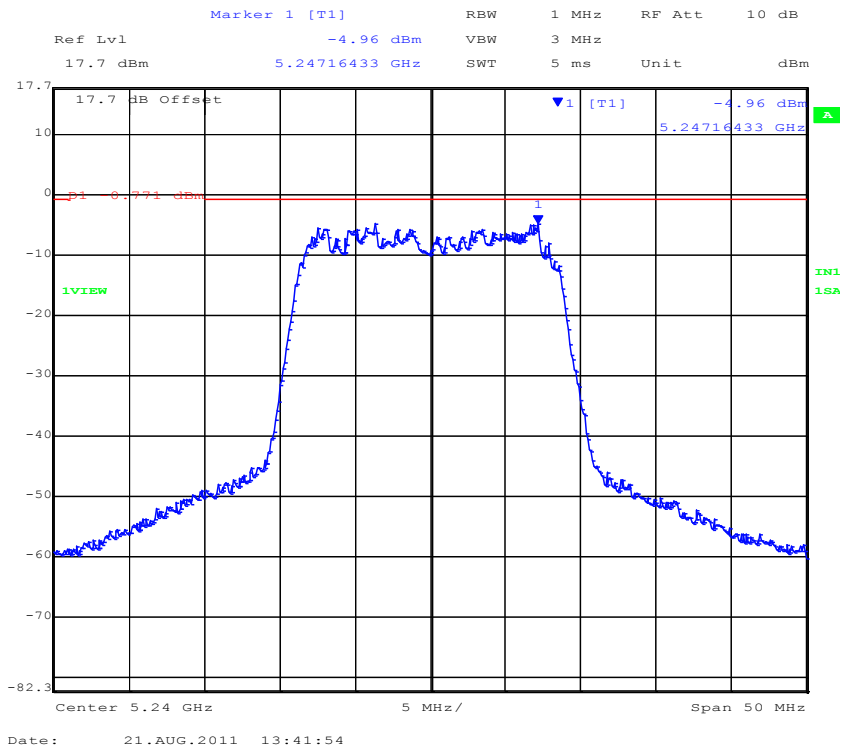

PORT B 5,240 MHz 802.11a Legacy Power Spectral Density

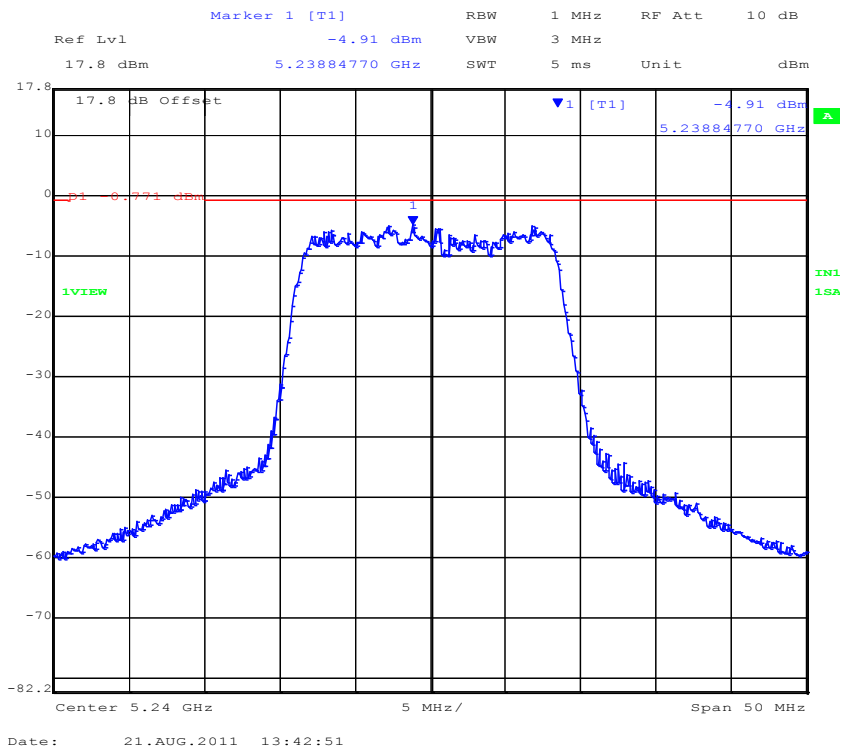

This test report may be reproduced in full only. The document may only be updated by MiCOM Labs personnel. Any changes will be noted in the Document History section of the report.



Title: NetScout Systems Inc. SENSOR4 Product Family
To: FCC 47 CFR Part 15.407 & IC RSS-247
Serial #: NTCT77-U3 Rev A
Issue Date: 12th December 2016
Page: 114 of 269

PORT C 5,240 MHz 802.11a Legacy Power Spectral Density

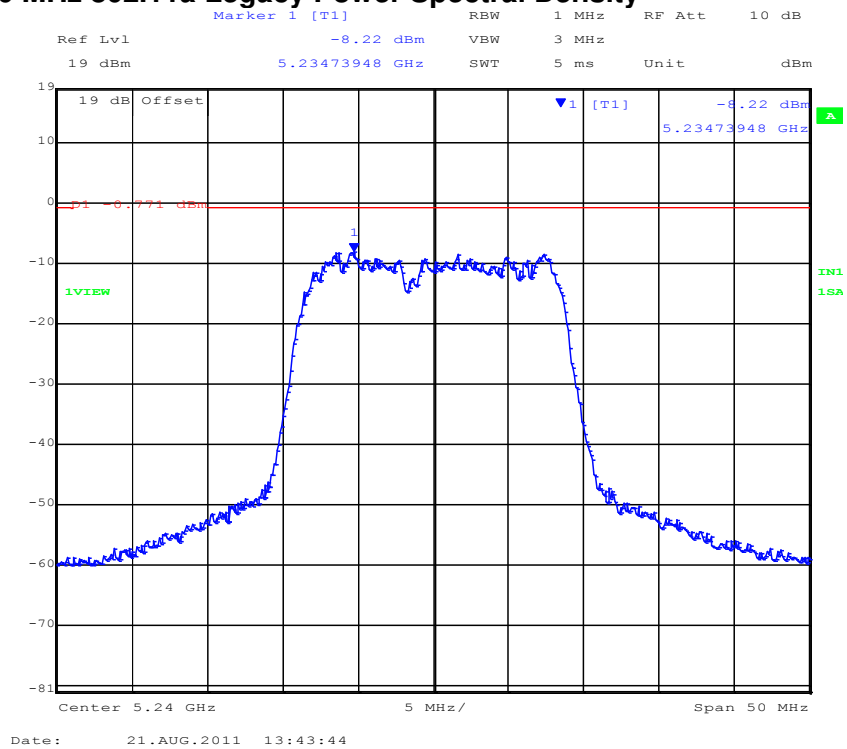

This test report may be reproduced in full only. The document may only be updated by MiCOM Labs personnel. Any changes will be noted in the Document History section of the report.



Title: NetScout Systems Inc. SENSOR4 Product Family
To: FCC 47 CFR Part 15.407 & IC RSS-247
Serial #: NTCT77-U3 Rev A
Issue Date: 12th December 2016
Page: 115 of 269

TABLE OF RESULTS – 802.11n HT-20 5150 – 5250 MHz

Test Conditions:	15.407 (a)	Rel. Humidity (%):	35	to	42
Variant:	802.11n HT-20	Ambient Temp. (°C):	19	to	22
TPC:	HIGH	Pressure (mBars):	998	to	1003
Modulation:	ON	Duty Cycle (%):	100		
Beam Forming Gain (Y):	N/A dB	Antenna Gain:	0 dBi		
Applied Voltage:	48.0 Vdc	Antenna Ports (N):	3		
Notes 1:					
Notes 2:					

Test Frequency	Measured Peak Power				Correction factor	Peak Power Spectral Density	Limit	Margin
	RF Port (dBm)							
MHz	a	b	c	d	10Log(N)	dBm	dBm	dB
5180	-1.84	-2.30	-5.90	--	4.77	2.93	4.00	-1.07
5200	-1.80	-0.84	-5.39	--	4.77	3.93	4.00	-0.07
5240	-1.69	-2.05	-5.72	--	4.77	3.08	4.00	-0.92

Measurement uncertainty:	±1.33 dB
---------------------------------	----------

This test report may be reproduced in full only. The document may only be updated by MiCOM Labs personnel. Any changes will be noted in the Document History section of the report.



Title: NetScout Systems Inc. SENSOR4 Product Family
To: FCC 47 CFR Part 15.407 & IC RSS-247
Serial #: NTCT77-U3 Rev A
Issue Date: 12th December 2016
Page: 116 of 269

PORT A 5,180 MHz 802.11n HT-20 Power Spectral Density

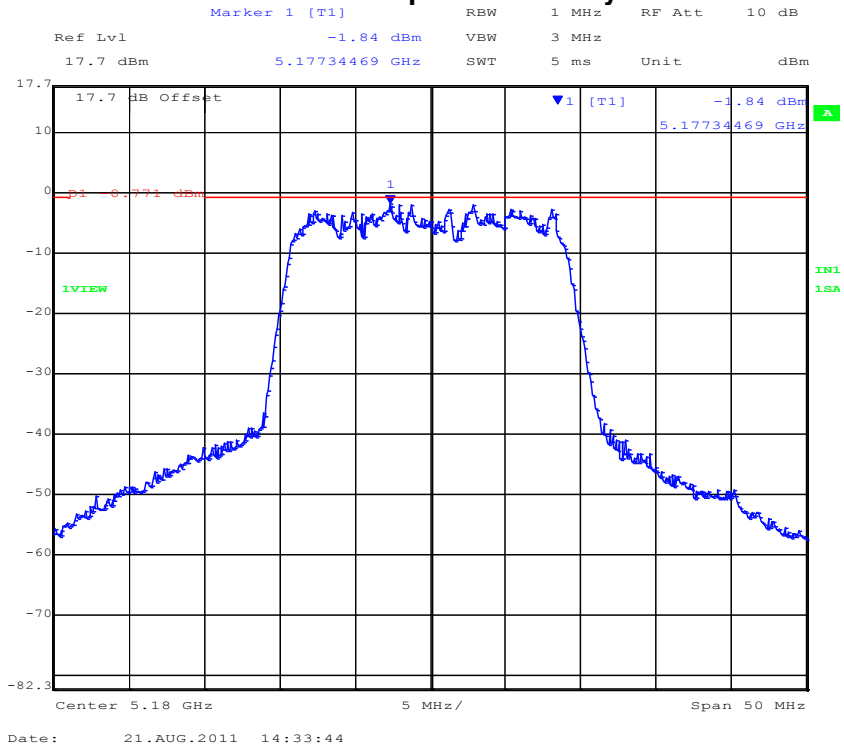

PORT B 5,180 MHz 802.11n HT-20 Power Spectral Density

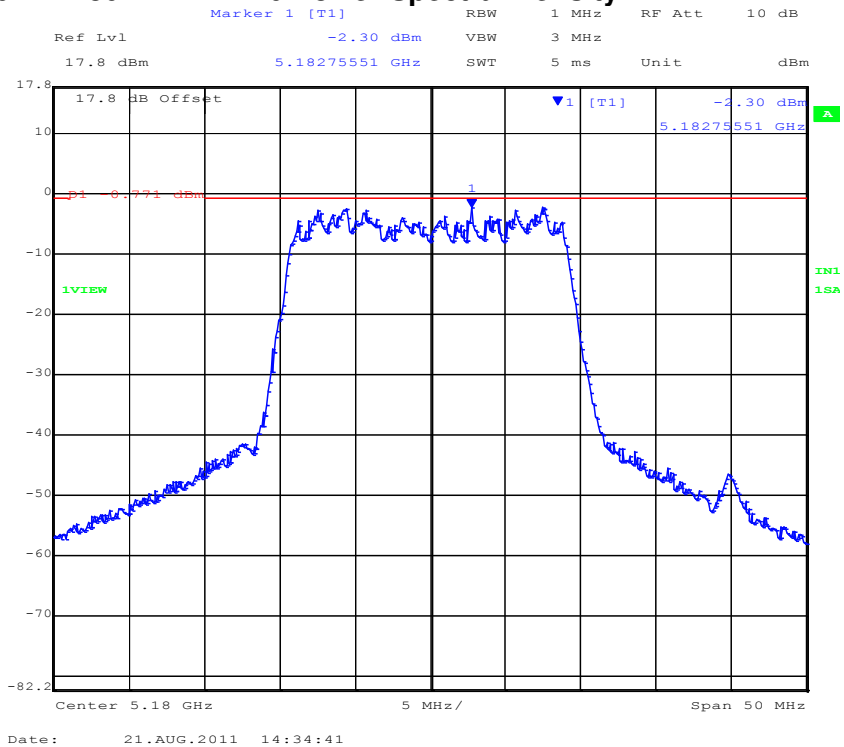

This test report may be reproduced in full only. The document may only be updated by MiCOM Labs personnel. Any changes will be noted in the Document History section of the report.



Title: NetScout Systems Inc. SENSOR4 Product Family
To: FCC 47 CFR Part 15.407 & IC RSS-247
Serial #: NTCT77-U3 Rev A
Issue Date: 12th December 2016
Page: 117 of 269

PORT C 5,180 MHz 802.11n HT-20 Power Spectral Density

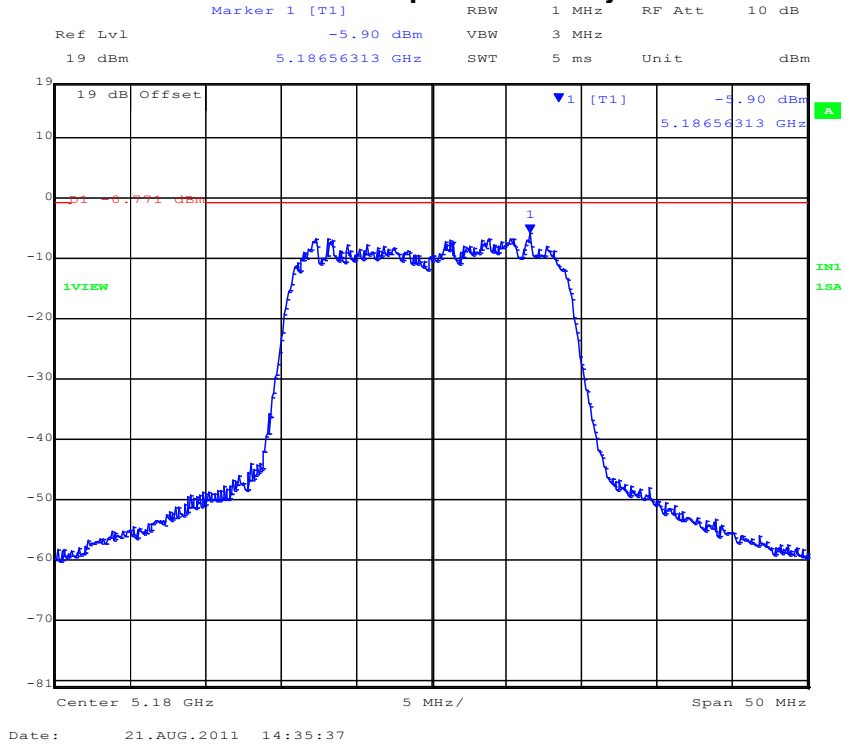

This test report may be reproduced in full only. The document may only be updated by MiCOM Labs personnel. Any changes will be noted in the Document History section of the report.



PORT A 5,200 MHz 802.11n HT-20 Power Spectral Density

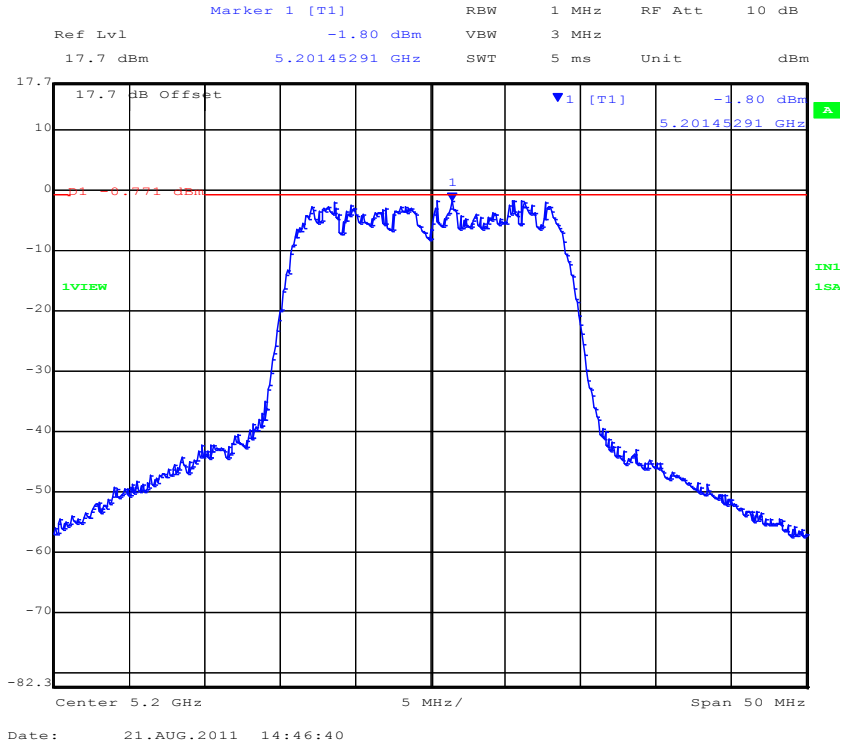

PORT B 5,200 MHz 802.11n HT-20 Power Spectral Density

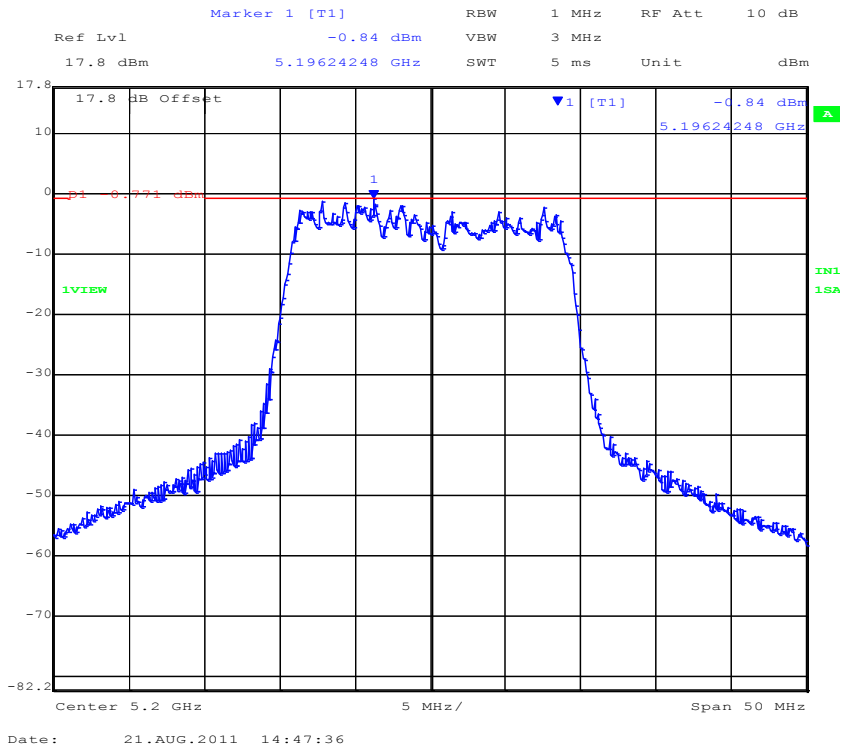

This test report may be reproduced in full only. The document may only be updated by MiCOM Labs personnel. Any changes will be noted in the Document History section of the report.



Title: NetScout Systems Inc. SENSOR4 Product Family
To: FCC 47 CFR Part 15.407 & IC RSS-247
Serial #: NTCT77-U3 Rev A
Issue Date: 12th December 2016
Page: 119 of 269

PORT C 5,200 MHz 802.11n HT-20 Power Spectral Density

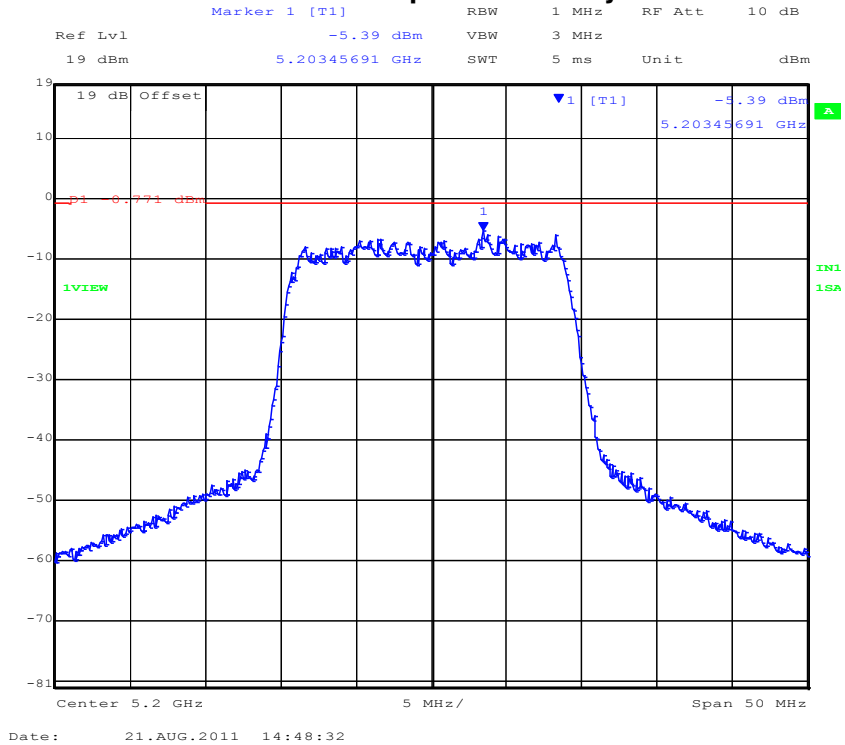

This test report may be reproduced in full only. The document may only be updated by MiCOM Labs personnel. Any changes will be noted in the Document History section of the report.



PORT A 5,240 MHz 802.11n HT-20 Power Spectral Density

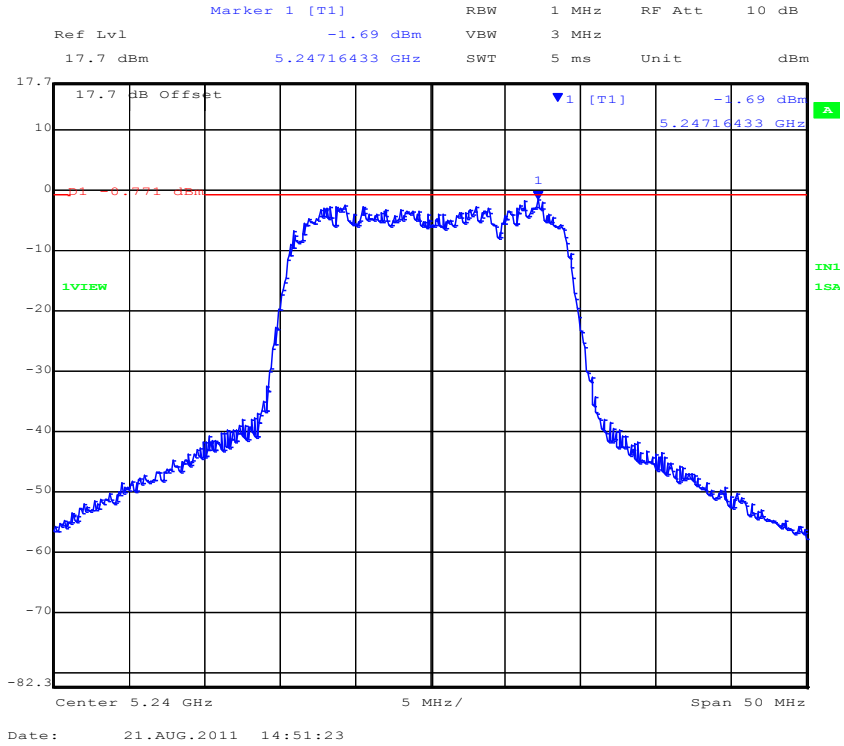

PORT B 5,240 MHz 802.11n HT-20 Power Spectral Density

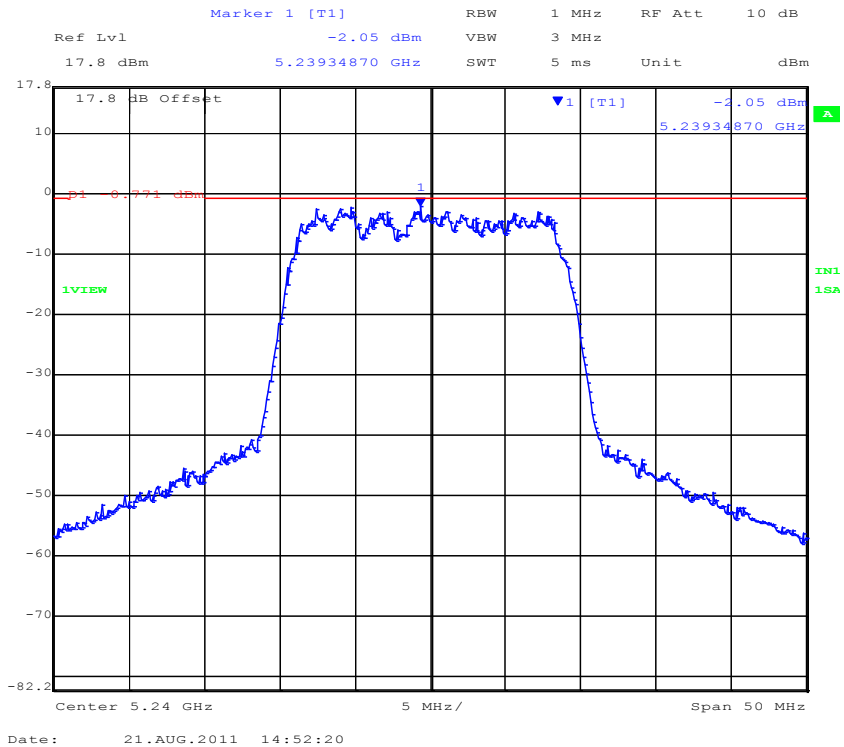

This test report may be reproduced in full only. The document may only be updated by MiCOM Labs personnel. Any changes will be noted in the Document History section of the report.



Title: NetScout Systems Inc. SENSOR4 Product Family
To: FCC 47 CFR Part 15.407 & IC RSS-247
Serial #: NTCT77-U3 Rev A
Issue Date: 12th December 2016
Page: 122 of 269

TABLE OF RESULTS – 802.11n HT-40 5150 – 5250 MHz

Test Conditions:	15.407 (a)	Rel. Humidity (%):	35	to	42
Variant:	802.11n HT-40	Ambient Temp. (°C):	19	to	22
TPC:	HIGH	Pressure (mBars):	998	to	1003
Modulation:	ON	Duty Cycle (%):	100		
Beam Forming Gain (Y):	N/A dB	Antenna Gain:	0 dBi		
Applied Voltage:	48.0 Vdc	Antenna Ports (N):	3		
Notes 1:					
Notes 2:					

Test Frequency	Measured Peak Power				Correction factor	Peak Power Spectral Density	Limit	Margin
	RF Port (dBm)							
MHz	a	b	c	d	10Log(N)	dBm	dBm	dB
5190.00	-3.75	-3.63	-7.21	--	4.77	1.14	4.00	-2.86
5230.00	-3.77	-3.52	-7.24	--	4.77	1.25	4.00	-2.75

Measurement uncertainty:	±1.33 dB
---------------------------------	----------

This test report may be reproduced in full only. The document may only be updated by MiCOM Labs personnel. Any changes will be noted in the Document History section of the report.



PORT A 5,190 MHz 802.11n HT-40 Power Spectral Density

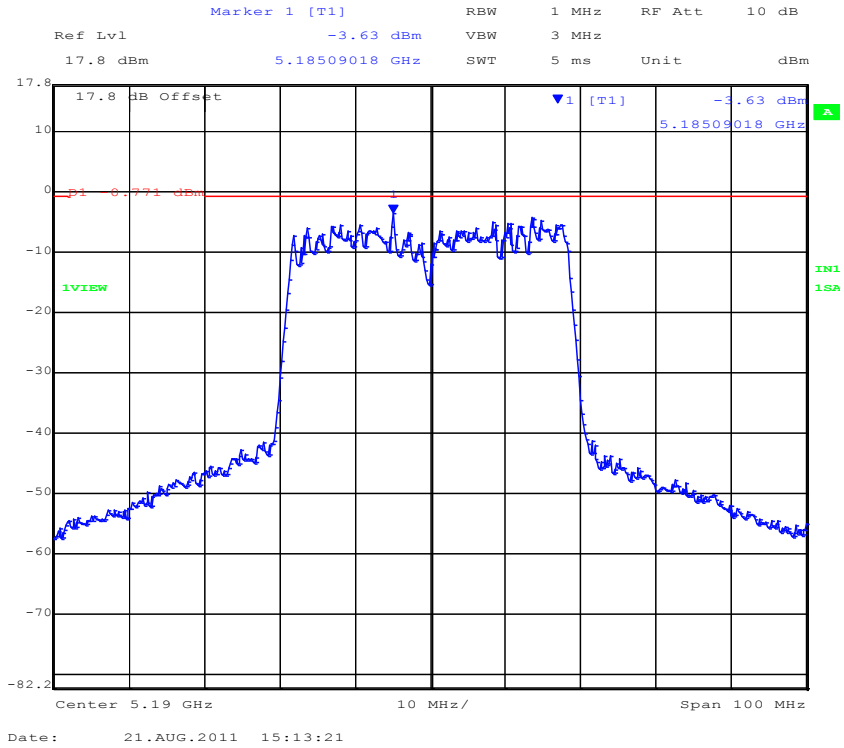

PORT B 5,190 MHz 802.11n HT-40 Power Spectral Density

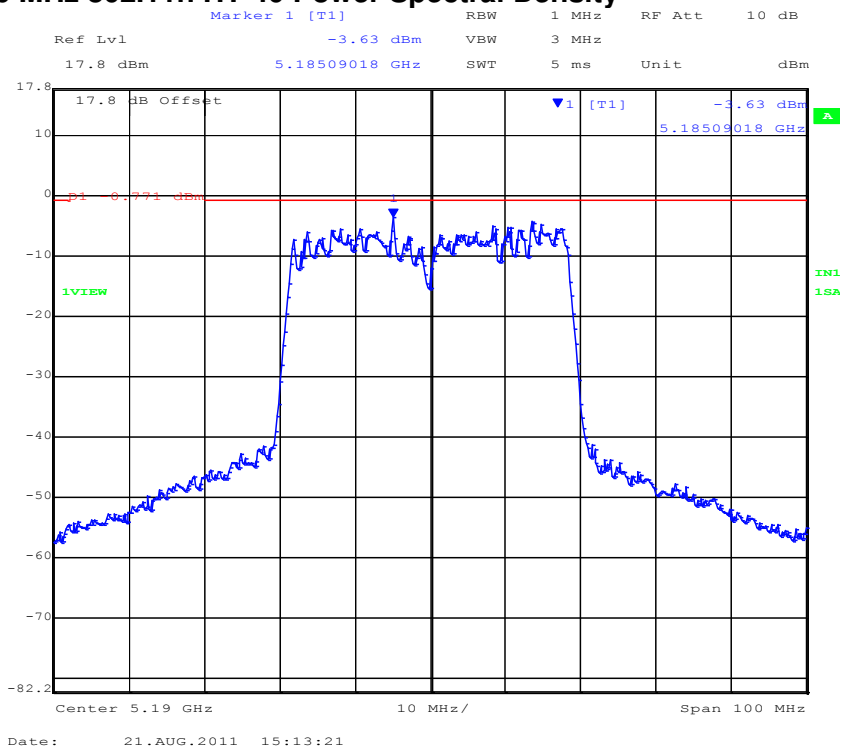

This test report may be reproduced in full only. The document may only be updated by MiCOM Labs personnel. Any changes will be noted in the Document History section of the report.



Title: NetScout Systems Inc. SENSOR4 Product Family
To: FCC 47 CFR Part 15.407 & IC RSS-247
Serial #: NTCT77-U3 Rev A
Issue Date: 12th December 2016
Page: 124 of 269

PORT C 5,190 MHz 802.11n HT-40 Power Spectral Density

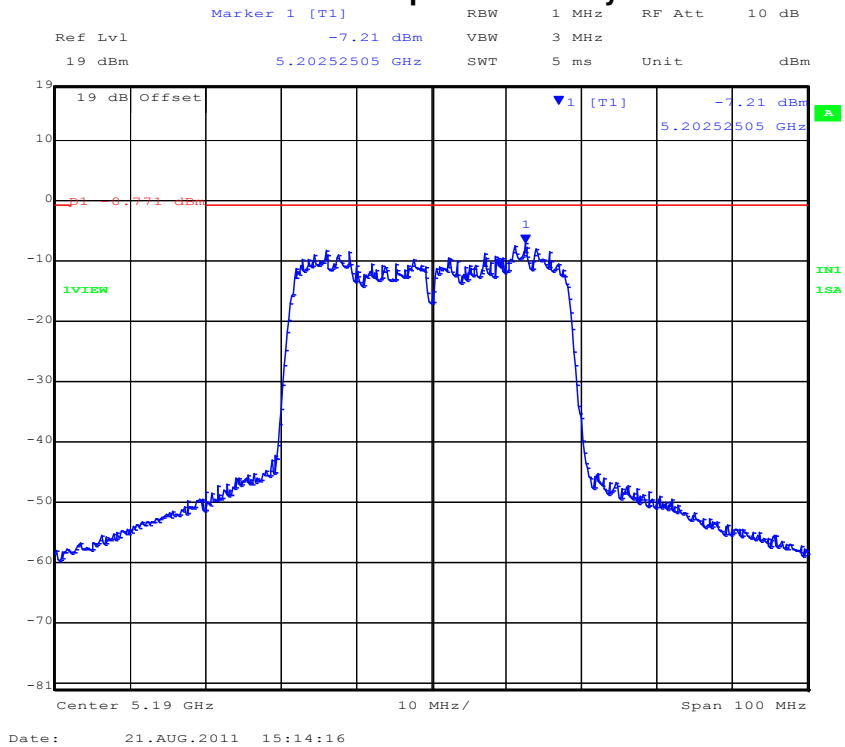

This test report may be reproduced in full only. The document may only be updated by MiCOM Labs personnel. Any changes will be noted in the Document History section of the report.



PORT A 5,230 MHz 802.11n HT-40 Power Spectral Density

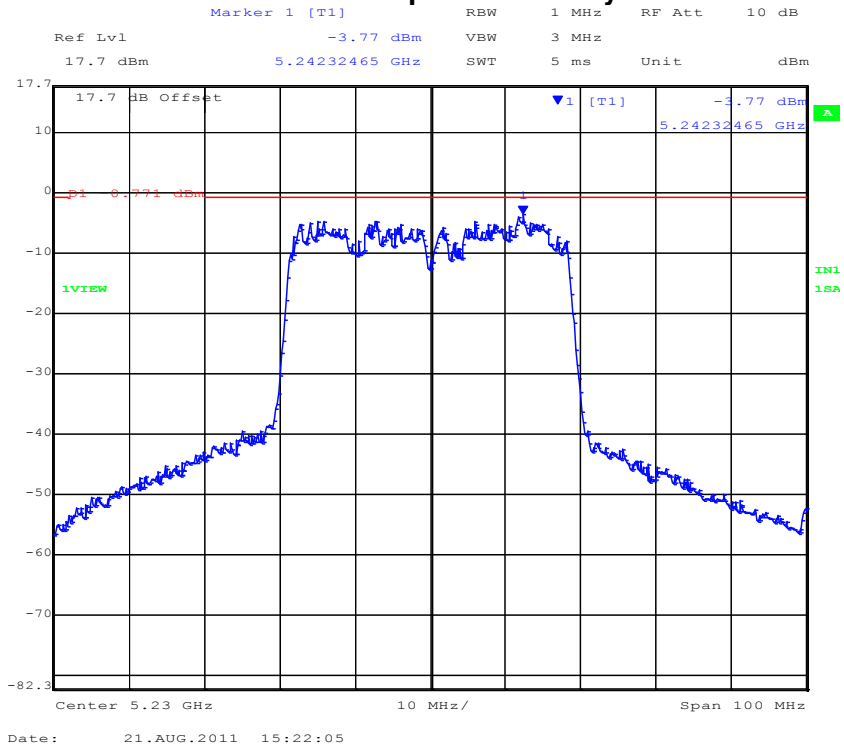

PORT B 5,230 MHz 802.11n HT-40 Power Spectral Density

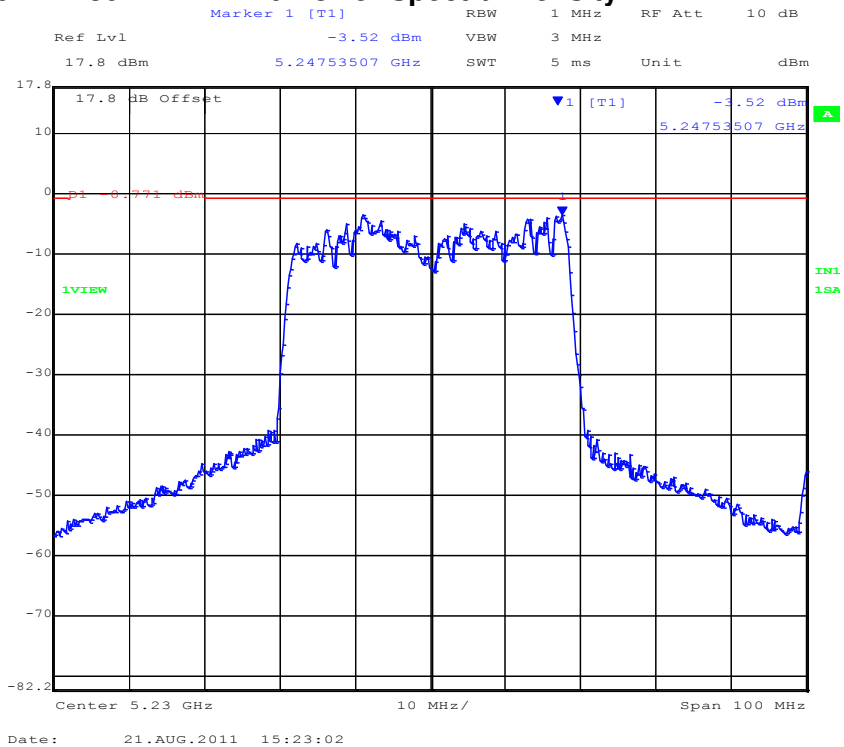

This test report may be reproduced in full only. The document may only be updated by MiCOM Labs personnel. Any changes will be noted in the Document History section of the report.



Title: NetScout Systems Inc. SENSOR4 Product Family
To: FCC 47 CFR Part 15.407 & IC RSS-247
Serial #: NTCT77-U3 Rev A
Issue Date: 12th December 2016
Page: 126 of 269

PORT C 5,230 MHz 802.11n HT-40 Power Spectral Density

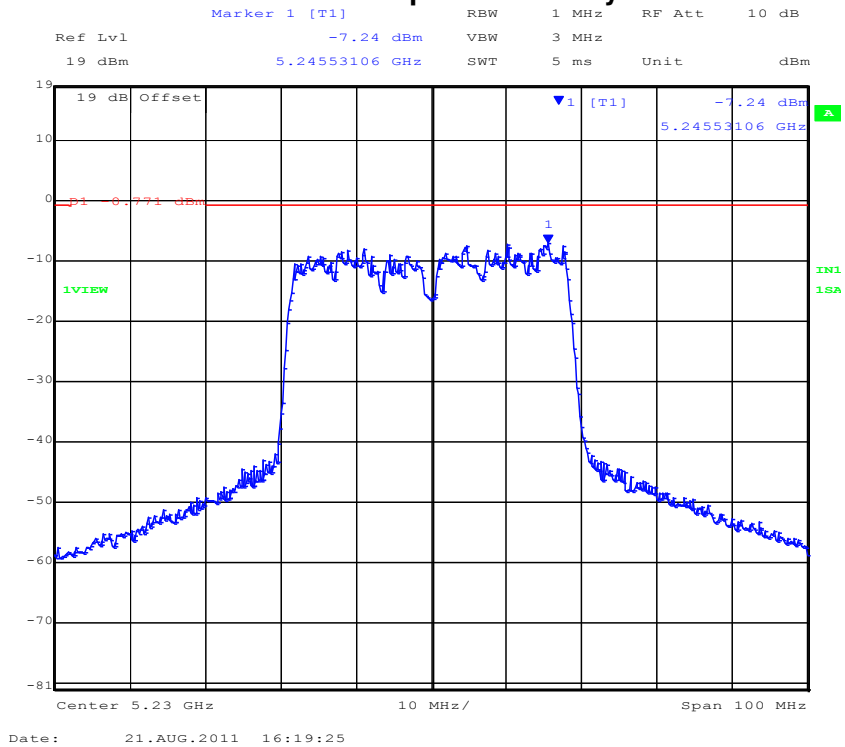

This test report may be reproduced in full only. The document may only be updated by MiCOM Labs personnel. Any changes will be noted in the Document History section of the report.



Title: NetScout Systems Inc. SENSOR4 Product Family
To: FCC 47 CFR Part 15.407 & IC RSS-247
Serial #: NTCT77-U3 Rev A
Issue Date: 12th December 2016
Page: 127 of 269

TABLE OF RESULTS – 802.11a Legacy 5250 -5350 MHz

Test Conditions:	15.407 (a)	Rel. Humidity (%):	35 to 42
Variant:	802.11a	Ambient Temp. (°C):	19 to 22
TPC:	HIGH	Pressure (mBars):	998 to 1003
Modulation:	ON	Duty Cycle (%):	100
Beam Forming Gain (Y):	N/A dB	Antenna Gain:	0 dBi
Applied Voltage:	48.0 Vdc	Antenna Ports (N):	3
Notes 1:			
Notes 2:			

Test Frequency	Measured Peak Power				Correction factor	Peak Power Spectral Density	Limit	Margin
	RF Port (dBm)							
MHz	a	b	c	d	10Log(N)	dBm	dBm	dB
5260.00	3.60	2.06	4.07	--	4.77	8.84	11.00	-2.16
5300.00	3.08	-0.61	4.04	--	4.77	8.81	11.00	-2.19
5320.00	3.47	-0.90	3.04	--	4.77	8.24	11.00	-2.76

Measurement uncertainty:	±1.33 dB
---------------------------------	----------

This test report may be reproduced in full only. The document may only be updated by MiCOM Labs personnel. Any changes will be noted in the Document History section of the report.



Title: NetScout Systems Inc. SENSOR4 Product Family
To: FCC 47 CFR Part 15.407 & IC RSS-247
Serial #: NTCT77-U3 Rev A
Issue Date: 12th December 2016
Page: 128 of 269

PORT A 5,260 MHz 802.11a Legacy Power Spectral Density

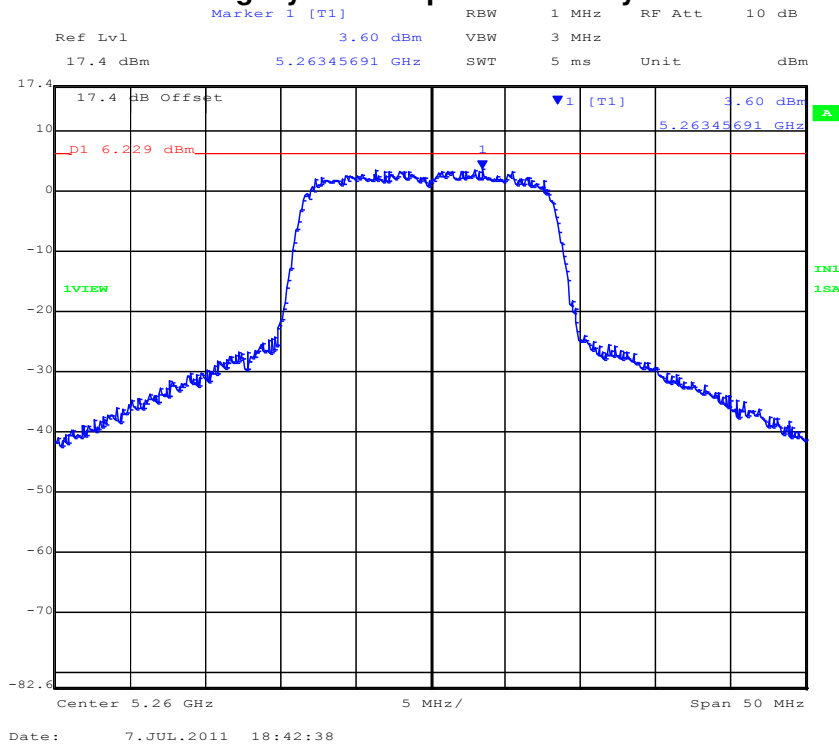

PORT B 5,260 MHz 802.11a Legacy Power Spectral Density

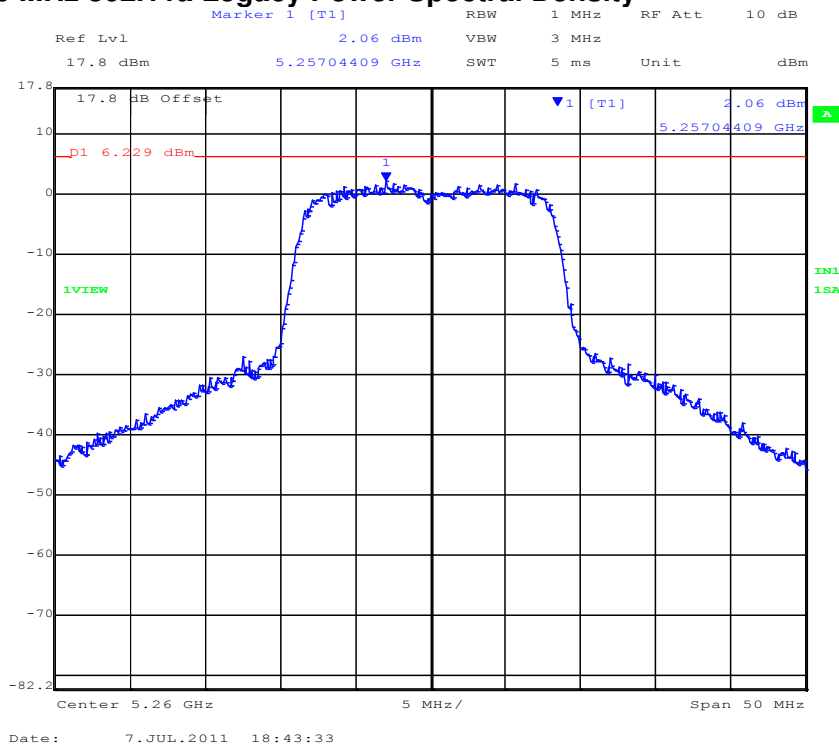

This test report may be reproduced in full only. The document may only be updated by MiCOM Labs personnel. Any changes will be noted in the Document History section of the report.



Title: NetScout Systems Inc. SENSOR4 Product Family
To: FCC 47 CFR Part 15.407 & IC RSS-247
Serial #: NTCT77-U3 Rev A
Issue Date: 12th December 2016
Page: 129 of 269

PORT C 5,260 MHz 802.11a Legacy Power Spectral Density

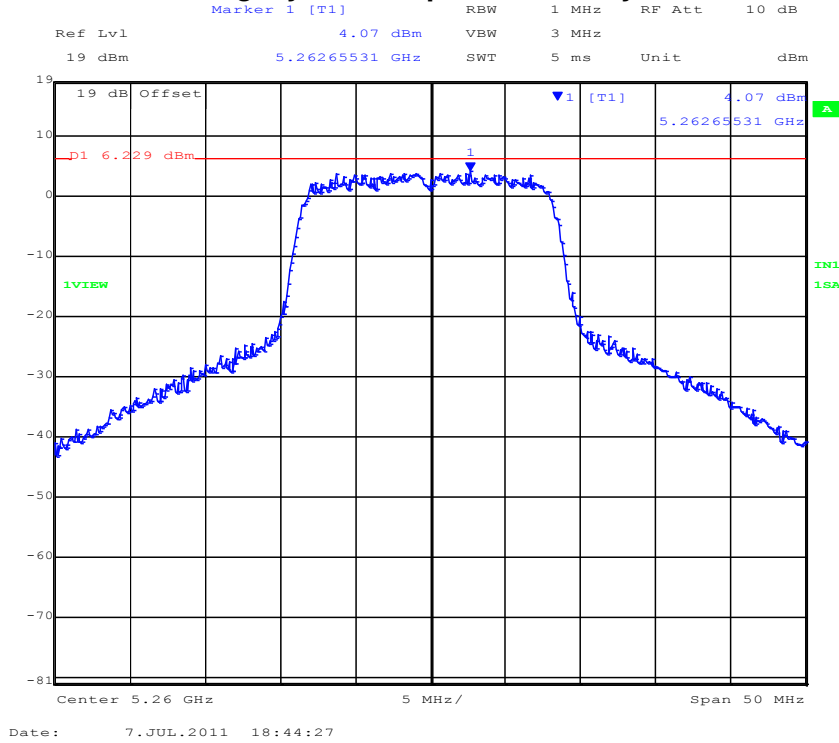

PORT A 5300 MHz 802.11a Legacy Power Spectral Density

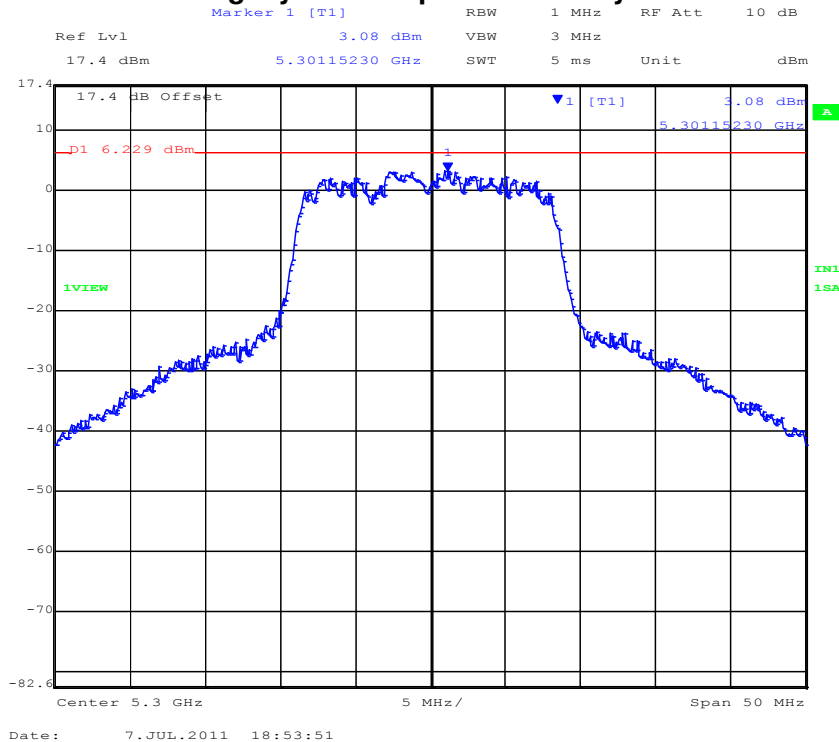

This test report may be reproduced in full only. The document may only be updated by MiCOM Labs personnel. Any changes will be noted in the Document History section of the report.



PORT B 5,300 MHz 802.11a Legacy Power Spectral Density

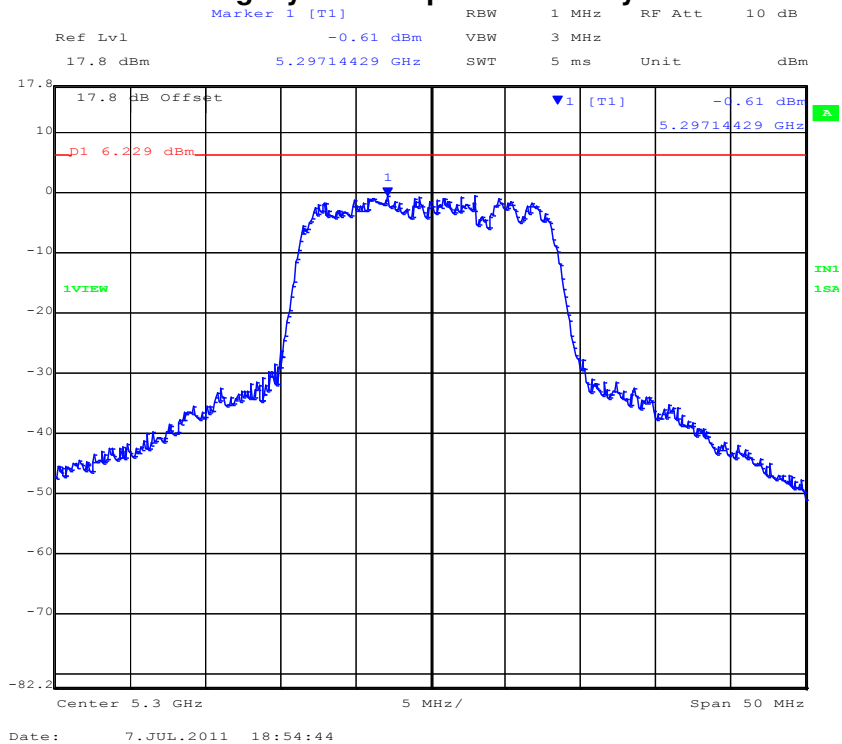

PORT C 5,300 MHz 802.11a Legacy Power Spectral Density

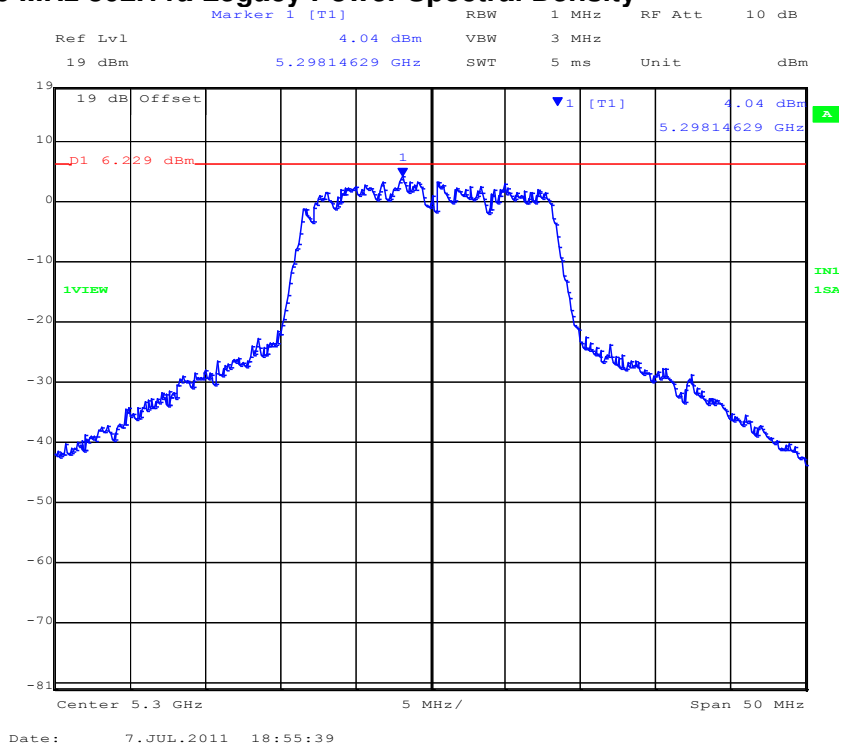

This test report may be reproduced in full only. The document may only be updated by MiCOM Labs personnel. Any changes will be noted in the Document History section of the report.



PORT A 5,320 MHz 802.11a Legacy Power Spectral Density

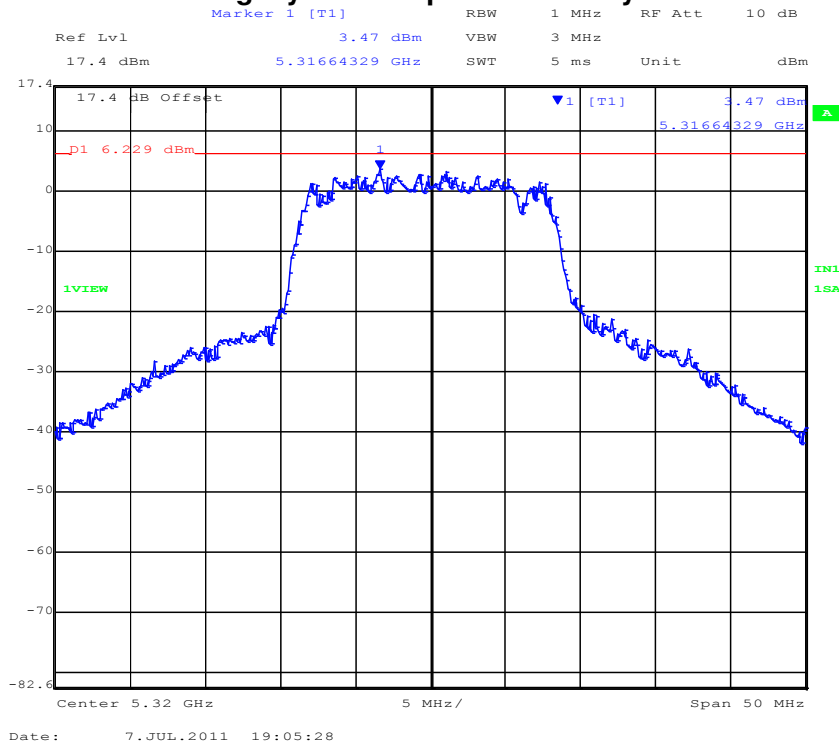

PORT B 5,320 MHz 802.11a Legacy Power Spectral Density

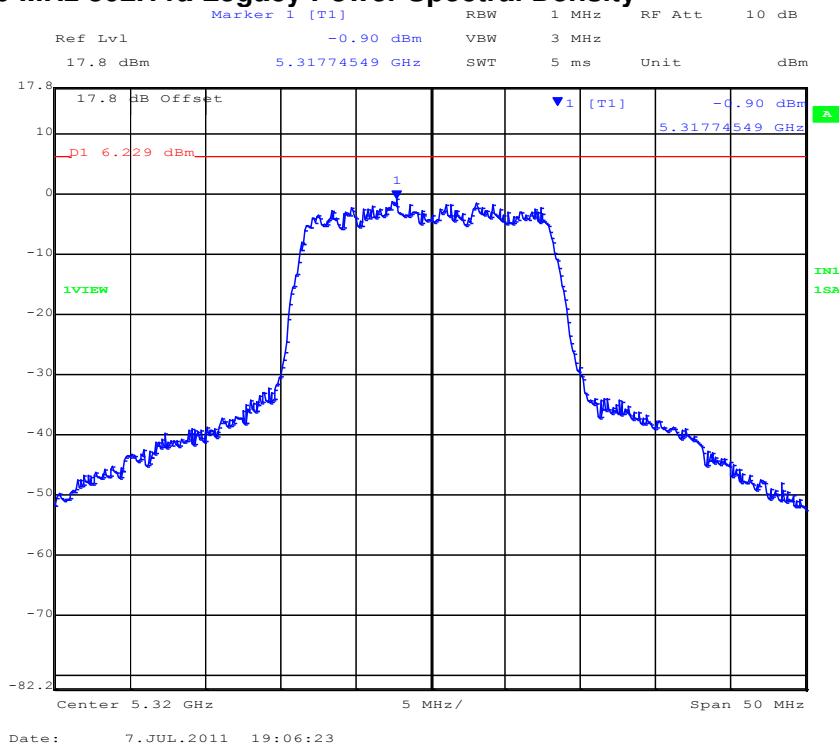

This test report may be reproduced in full only. The document may only be updated by MiCOM Labs personnel. Any changes will be noted in the Document History section of the report.



Title: NetScout Systems Inc. SENSOR4 Product Family
To: FCC 47 CFR Part 15.407 & IC RSS-247
Serial #: NTCT77-U3 Rev A
Issue Date: 12th December 2016
Page: 132 of 269

PORT C 5,320 MHz 802.11a Legacy Power Spectral Density

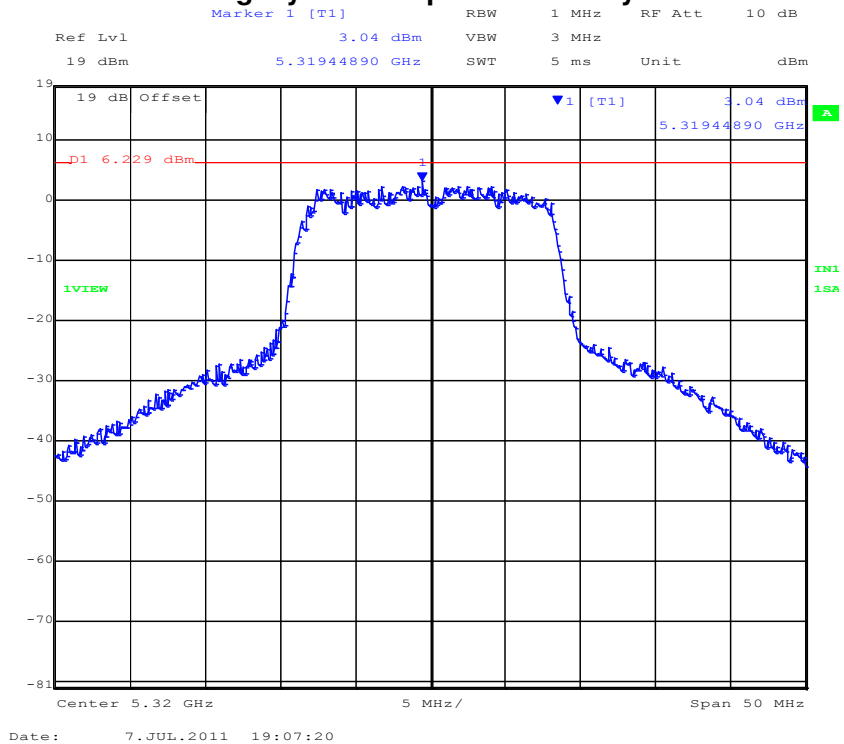

This test report may be reproduced in full only. The document may only be updated by MiCOM Labs personnel. Any changes will be noted in the Document History section of the report.



Title: NetScout Systems Inc. SENSOR4 Product Family
To: FCC 47 CFR Part 15.407 & IC RSS-247
Serial #: NTCT77-U3 Rev A
Issue Date: 12th December 2016
Page: 133 of 269

TABLE OF RESULTS – 802.11n HT-20 5250 -5350 MHz

Test Conditions:	15.407 (a)	Rel. Humidity (%):	35	to	42
Variant:	802.11n HT-20	Ambient Temp. (°C):	19	to	22
TPC:	HIGH	Pressure (mBars):	998	to	1003
Modulation:	ON	Duty Cycle (%):	100		
Beam Forming Gain (Y):	N/A dB	Antenna Gain:	0 dBi		
Applied Voltage:	48.0 Vdc	Antenna Ports (N):	3		
Notes 1:					
Notes 2:					

Test Frequency	Measured Peak Power				Correction factor	Peak Power Spectral Density	Limit	Margin
	RF Port (dBm)							
MHz	a	b	c	d	10Log(N)	dBm	dBm	dB
5260.00	2.68	1.28	3.32	--	4.77	8.09	11.00	-2.91
5300.00	2.68	0.01	3.60	--	4.77	8.37	11.00	-2.63
5320.00	2.60	-2.12	3.21	--	4.77	7.98	11.00	-3.02

Measurement uncertainty:	±1.33 dB
---------------------------------	----------

This test report may be reproduced in full only. The document may only be updated by MiCOM Labs personnel. Any changes will be noted in the Document History section of the report.



Title: NetScout Systems Inc. SENSOR4 Product Family
To: FCC 47 CFR Part 15.407 & IC RSS-247
Serial #: NTCT77-U3 Rev A
Issue Date: 12th December 2016
Page: 134 of 269

PORT A 5,260 MHz 802.11n HT-20 Power Spectral Density

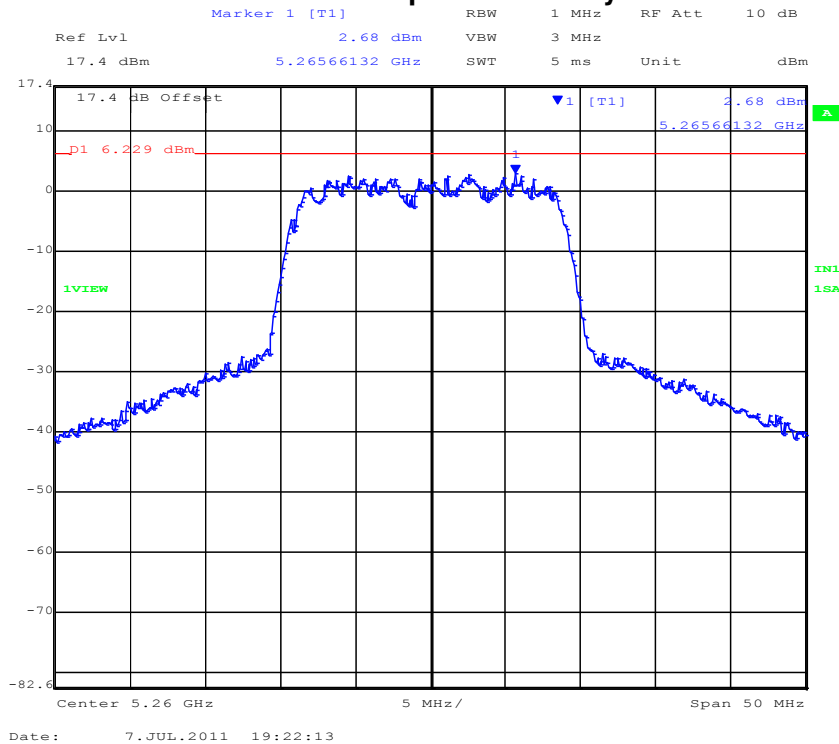

PORT B 5,260 MHz 802.11n HT-20 Power Spectral Density

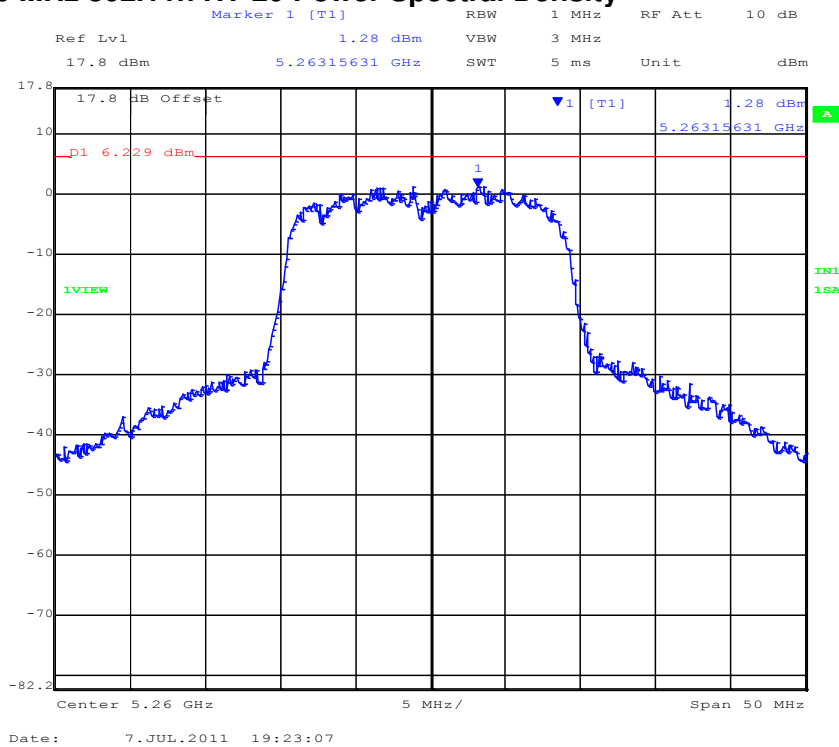

This test report may be reproduced in full only. The document may only be updated by MiCOM Labs personnel. Any changes will be noted in the Document History section of the report.



PORT C 5,260 MHz 802.11n HT-20 Power Spectral Density

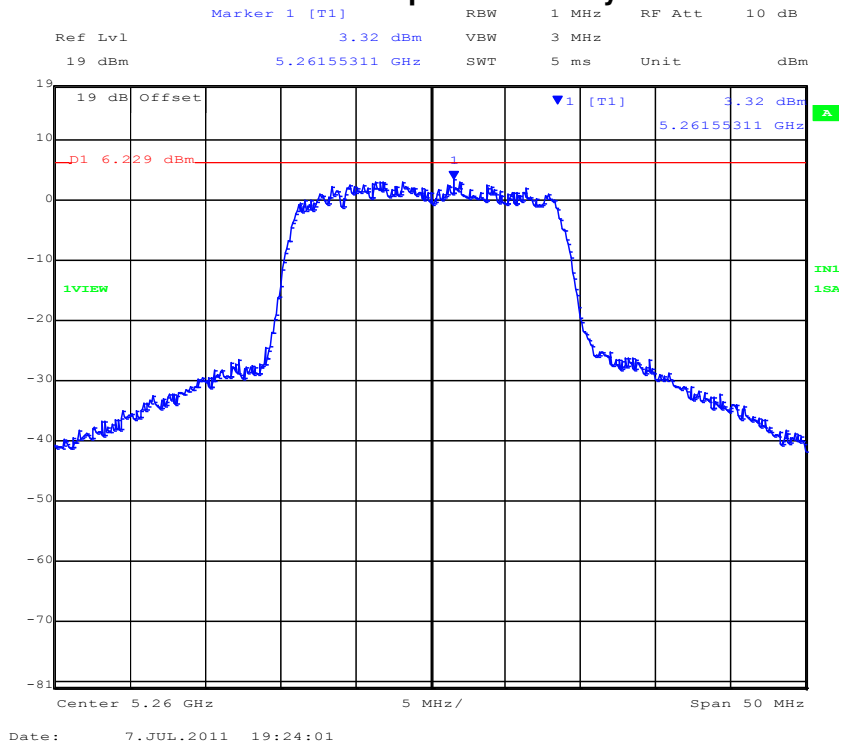

PORT A 5300 MHz 802.11n HT-20 Power Spectral Density

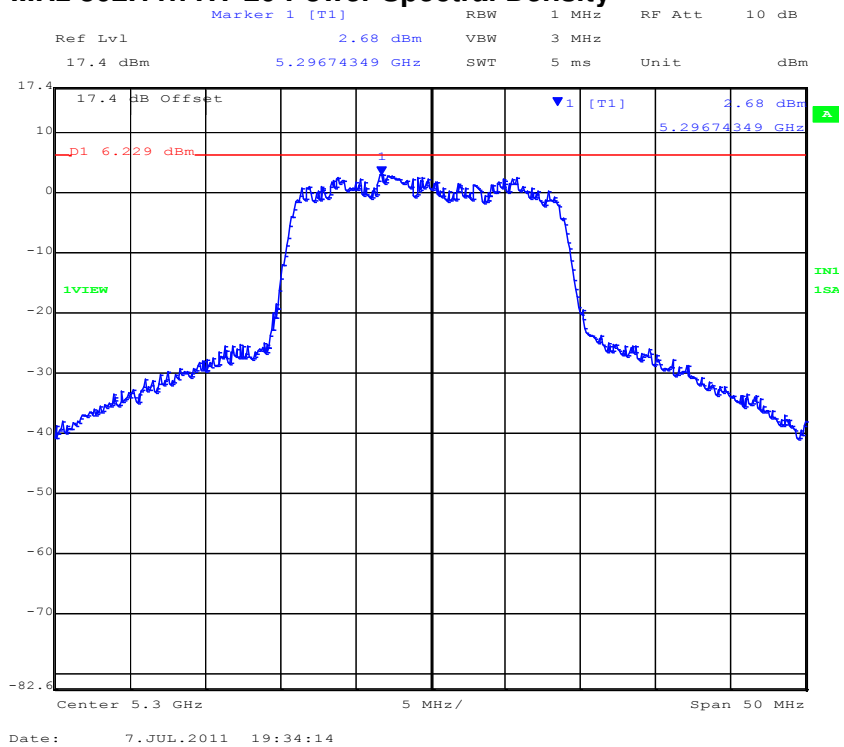

This test report may be reproduced in full only. The document may only be updated by MiCOM Labs personnel. Any changes will be noted in the Document History section of the report.



Title: NetScout Systems Inc. SENSOR4 Product Family
To: FCC 47 CFR Part 15.407 & IC RSS-247
Serial #: NTCT77-U3 Rev A
Issue Date: 12th December 2016
Page: 136 of 269

PORT B 5,300 MHz 802.11n HT-20 Power Spectral Density

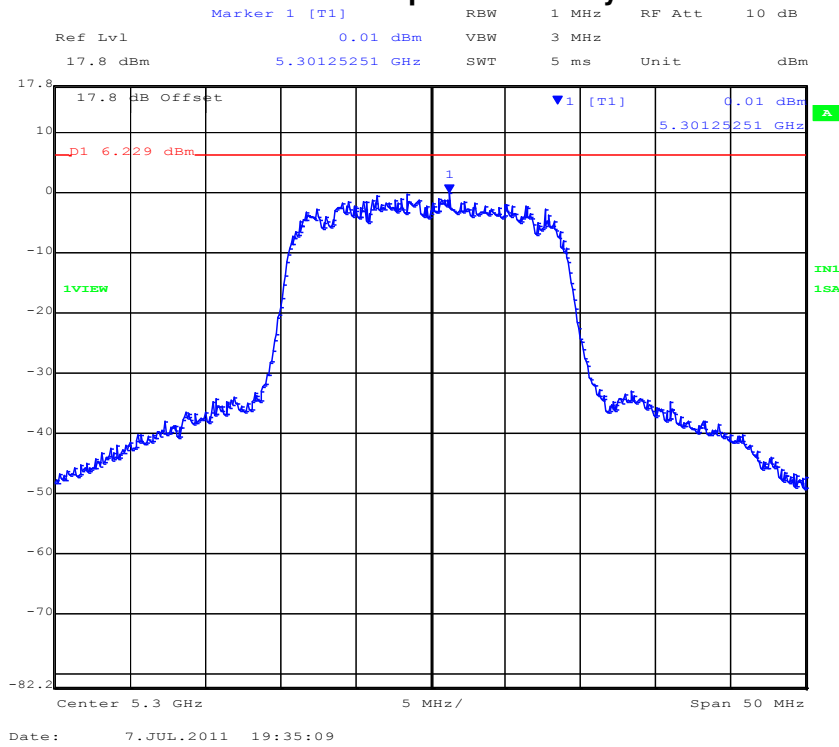

PORT C 5,300 MHz 802.11n HT-20 Power Spectral Density

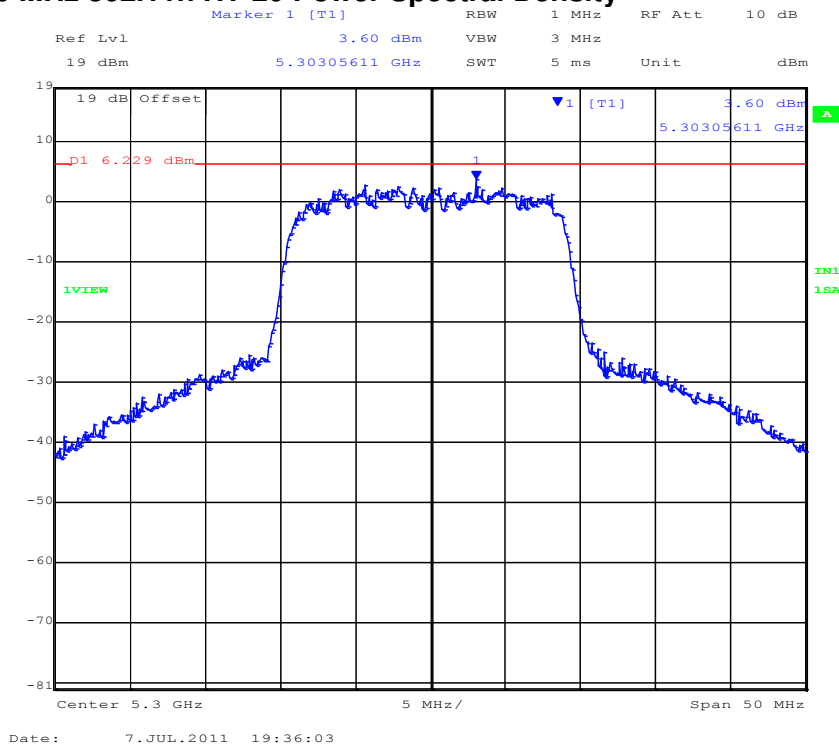

This test report may be reproduced in full only. The document may only be updated by MiCOM Labs personnel. Any changes will be noted in the Document History section of the report.



Title: NetScout Systems Inc. SENSOR4 Product Family
To: FCC 47 CFR Part 15.407 & IC RSS-247
Serial #: NTCT77-U3 Rev A
Issue Date: 12th December 2016
Page: 137 of 269

PORT A 5,320 MHz 802.11n HT-20 Power Spectral Density

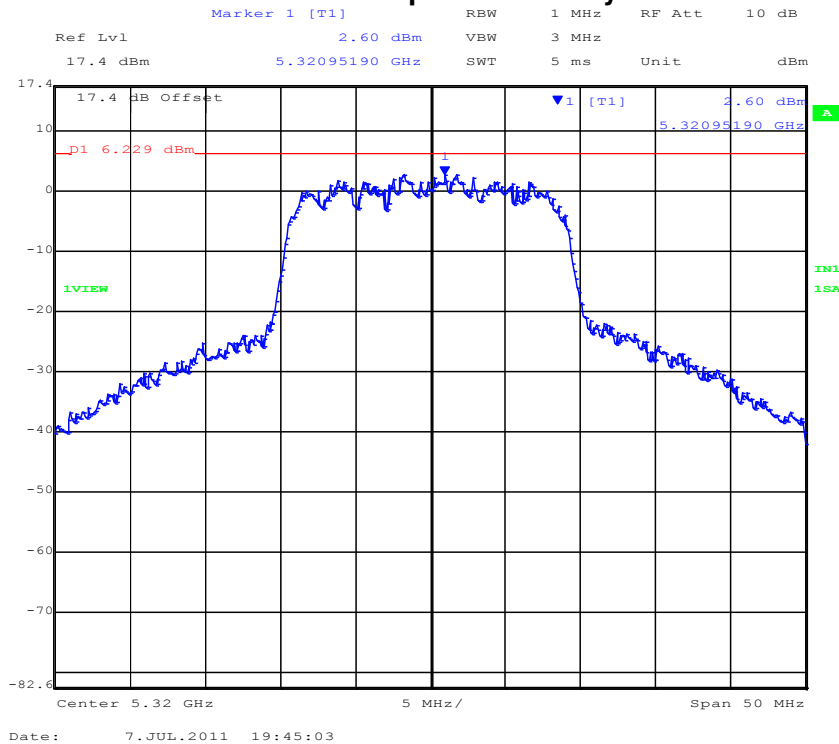

PORT B 5,320 MHz 802.11n HT-20 Power Spectral Density

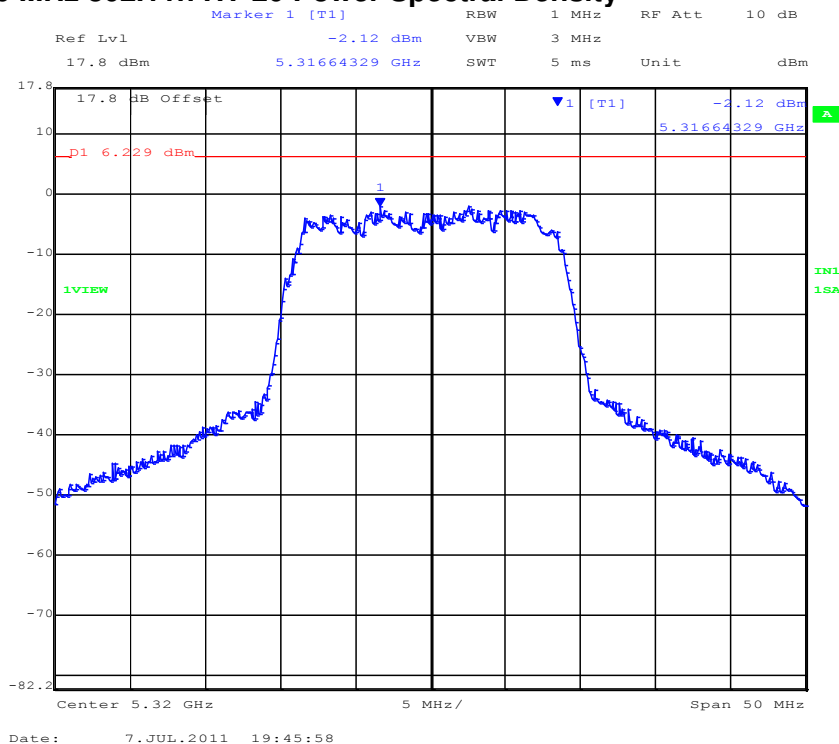

This test report may be reproduced in full only. The document may only be updated by MiCOM Labs personnel. Any changes will be noted in the Document History section of the report.



Title: NetScout Systems Inc. SENSOR4 Product Family
To: FCC 47 CFR Part 15.407 & IC RSS-247
Serial #: NTCT77-U3 Rev A
Issue Date: 12th December 2016
Page: 138 of 269

PORT C 5,320 MHz 802.11n HT-20 Power Spectral Density

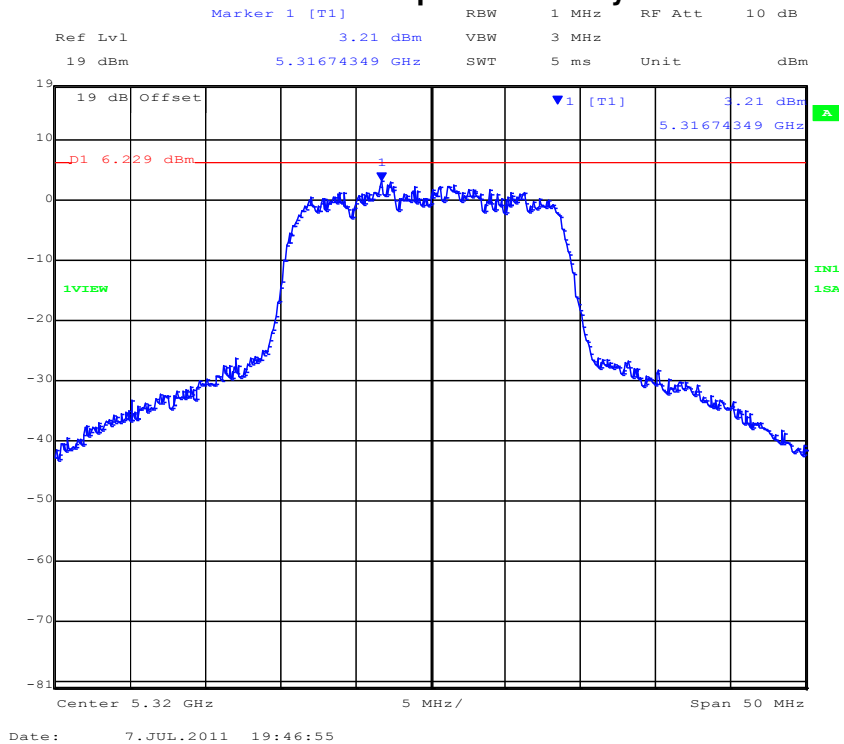

This test report may be reproduced in full only. The document may only be updated by MiCOM Labs personnel. Any changes will be noted in the Document History section of the report.



Title: NetScout Systems Inc. SENSOR4 Product Family
To: FCC 47 CFR Part 15.407 & IC RSS-247
Serial #: NTCT77-U3 Rev A
Issue Date: 12th December 2016
Page: 139 of 269

TABLE OF RESULTS – 802.11n HT-40 5250 -5350 MHz

Test Conditions:	15.407 (a)	Rel. Humidity (%):	35	to	42
Variant:	802.11n HT-40	Ambient Temp. (°C):	19	to	22
TPC:	HIGH	Pressure (mBars):	998	to	1003
Modulation:	ON	Duty Cycle (%):	100		
Beam Forming Gain (Y):	N/A dB	Antenna Gain:	0 dBi		
Applied Voltage:	48.0 Vdc	Antenna Ports (N):	3		
Notes 1:					
Notes 2:					

Test Frequency	Measured Peak Power				Correction factor	Peak Power Spectral Density	Limit	Margin
	RF Port (dBm)							
MHz	a	b	c	d	10Log(N)	dBm	dBm	dB
5270.00	-1.23	-3.64	-1.15	--	4.77	3.62	11.00	-7.38
5310.00	-1.65	-5.56	-0.98	--	4.77	3.79	11.00	-7.21

Measurement uncertainty:	±1.33 dB
---------------------------------	----------

This test report may be reproduced in full only. The document may only be updated by MiCOM Labs personnel. Any changes will be noted in the Document History section of the report.



Title: NetScout Systems Inc. SENSOR4 Product Family
To: FCC 47 CFR Part 15.407 & IC RSS-247
Serial #: NTCT77-U3 Rev A
Issue Date: 12th December 2016
Page: 140 of 269

PORT A 5,270 MHz 802.11n HT-40 Power Spectral Density

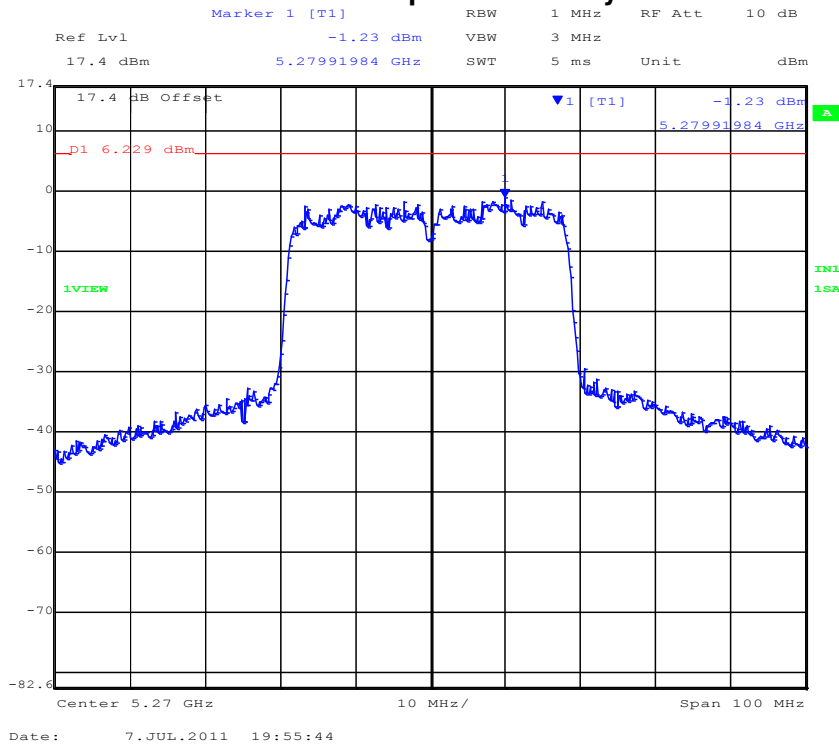

PORT B 5,270 MHz 802.11n HT-40 Power Spectral Density

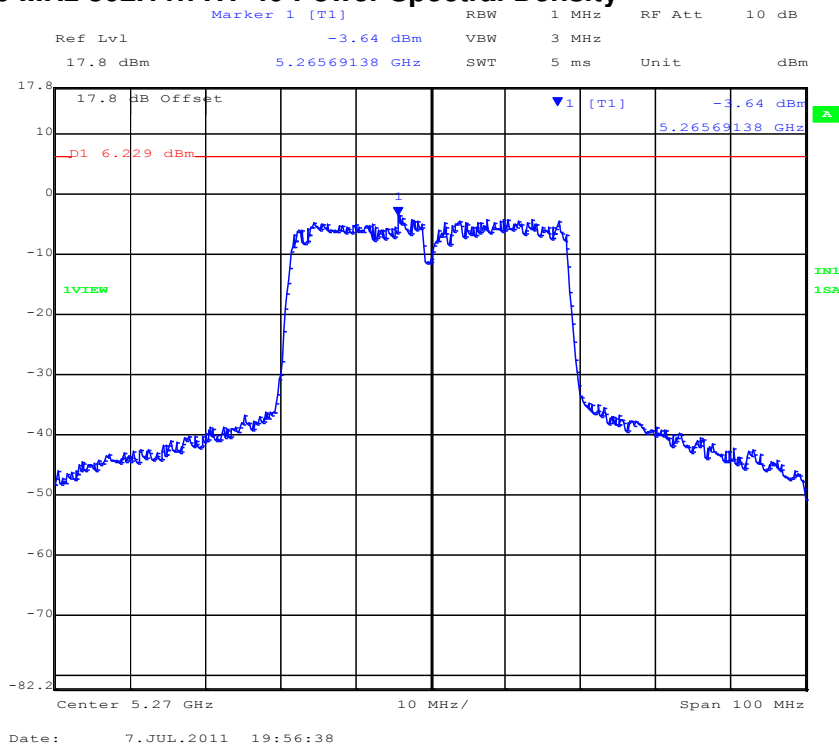

This test report may be reproduced in full only. The document may only be updated by MiCOM Labs personnel. Any changes will be noted in the Document History section of the report.



PORT C 5,270 MHz 802.11n HT-40 Power Spectral Density

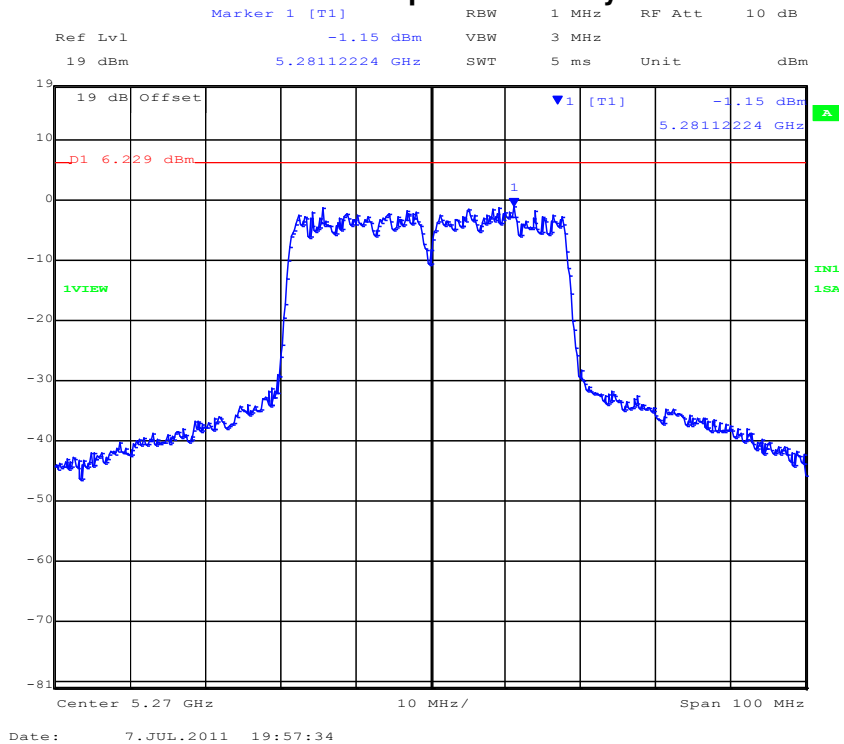

PORT A 5,310 MHz 802.11n HT-40 Power Spectral Density

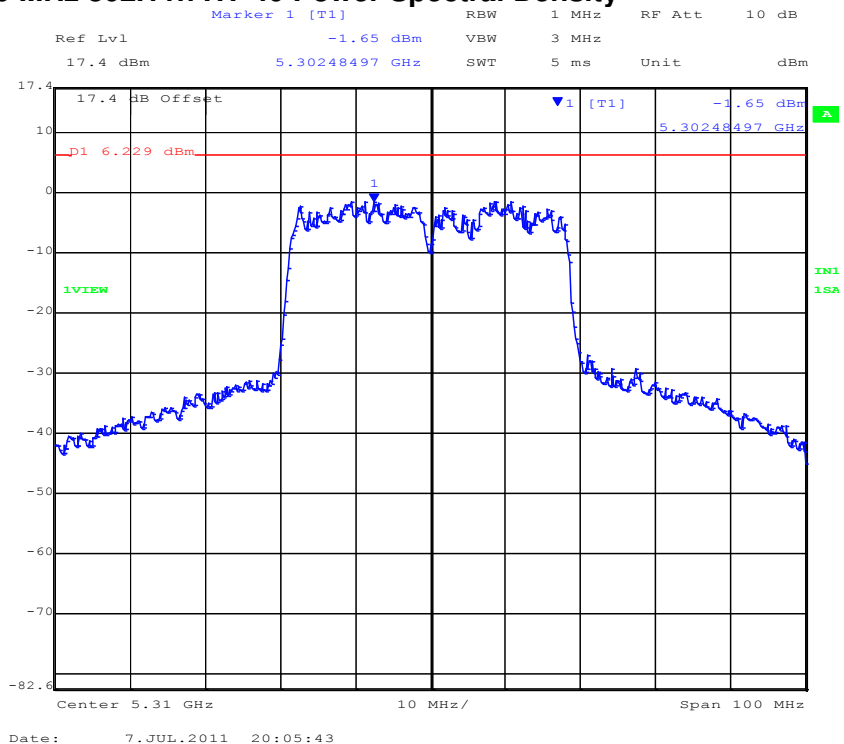

This test report may be reproduced in full only. The document may only be updated by MiCOM Labs personnel. Any changes will be noted in the Document History section of the report.



PORT B 5,310 MHz 802.11n HT-40 Power Spectral Density

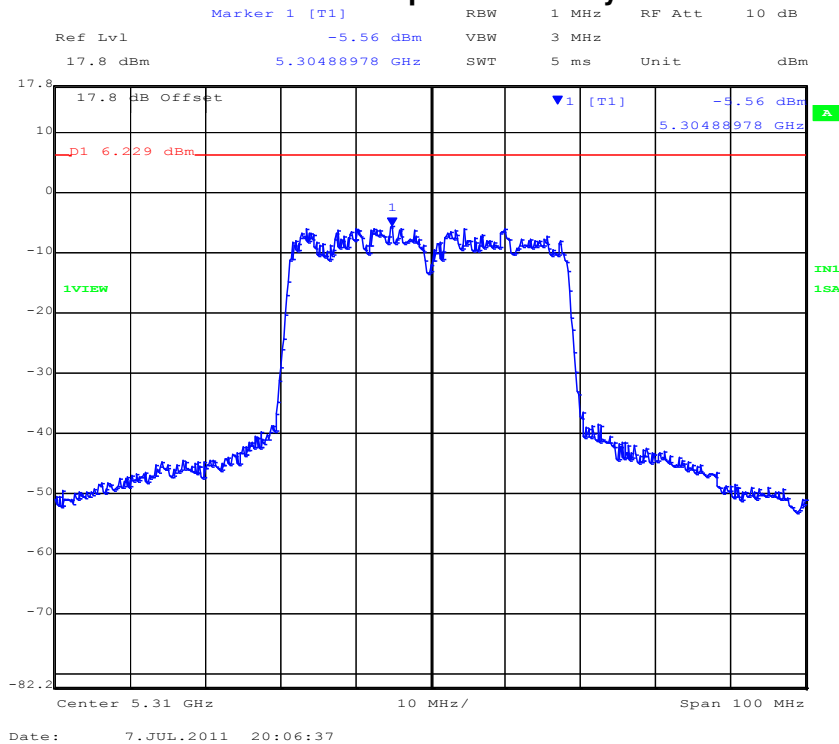

PORT C 5,310 MHz 802.11n HT-40 Power Spectral Density

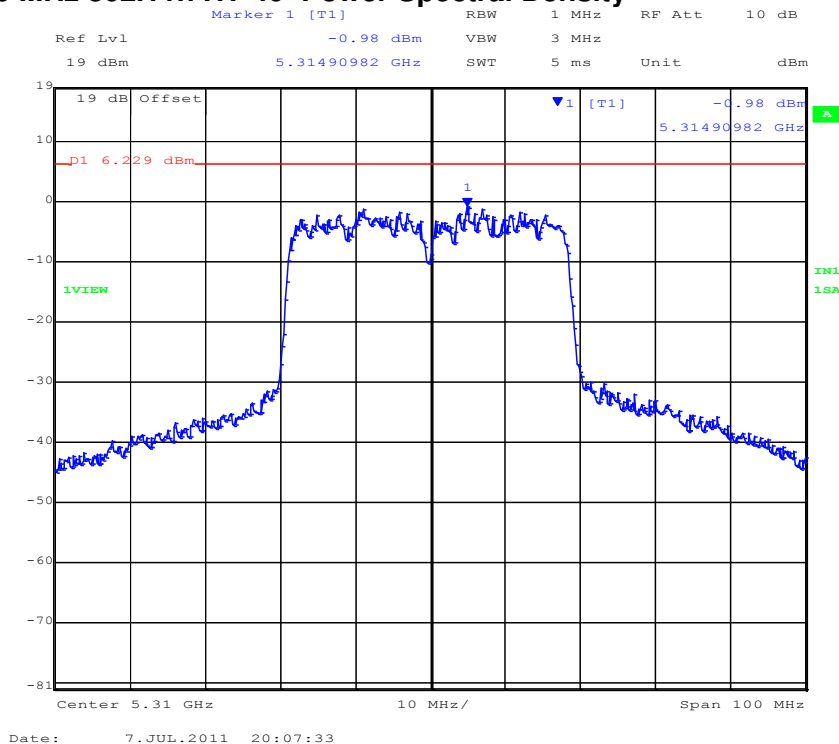

This test report may be reproduced in full only. The document may only be updated by MiCOM Labs personnel. Any changes will be noted in the Document History section of the report.



Title: NetScout Systems Inc. SENSOR4 Product Family
To: FCC 47 CFR Part 15.407 & IC RSS-247
Serial #: NTCT77-U3 Rev A
Issue Date: 12th December 2016
Page: 143 of 269

TABLE OF RESULTS – 802.11a Legacy 5500 - 5700 MHz

Test Conditions:	15.407 (a)	Rel. Humidity (%):	35	to	42
Variant:	802.11a	Ambient Temp. (°C):	19	to	22
TPC:	HIGH	Pressure (mBars):	998	to	1003
Modulation:	ON	Duty Cycle (%):	100		
Beam Forming Gain (Y):	N/A dB	Antenna Gain:	0 dBi		
Applied Voltage:	48.0 Vdc	Antenna Ports (N):	3		
Notes 1:					
Notes 2:					

Test Frequency	Measured Peak Power				Correction factor	Peak Power Spectral Density	Limit	Margin
	RF Port (dBm)							
MHz	a	b	c	d	10Log(N)	dBm	dBm	dB
5500.00	1.54	1.39	0.99	--	4.77	6.31	11.00	-4.69
5580.00	2.21	0.90	3.42	--	4.77	8.19	11.00	-2.81
5700.00	1.69	0.24	1.82	--	4.77	6.59	11.00	-4.41

Measurement uncertainty:	±1.33 dB
---------------------------------	----------

This test report may be reproduced in full only. The document may only be updated by MiCOM Labs personnel. Any changes will be noted in the Document History section of the report.



Title: NetScout Systems Inc. SENSOR4 Product Family
To: FCC 47 CFR Part 15.407 & IC RSS-247
Serial #: NTCT77-U3 Rev A
Issue Date: 12th December 2016
Page: 144 of 269

PORT A 5,500 MHz 802.11a Legacy Power Spectral Density

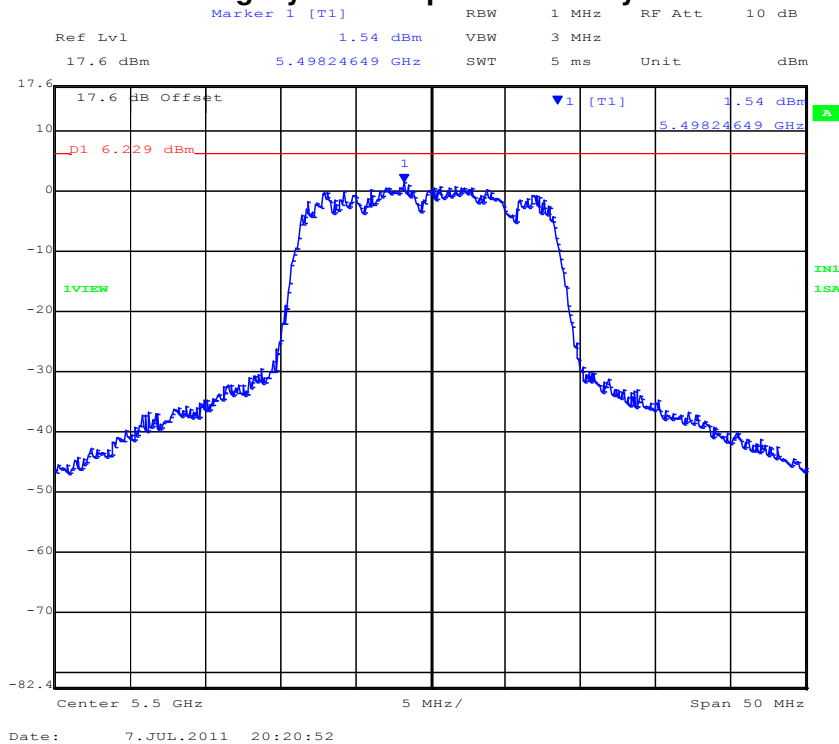

PORT B 5,500 MHz 802.11a Legacy Power Spectral Density

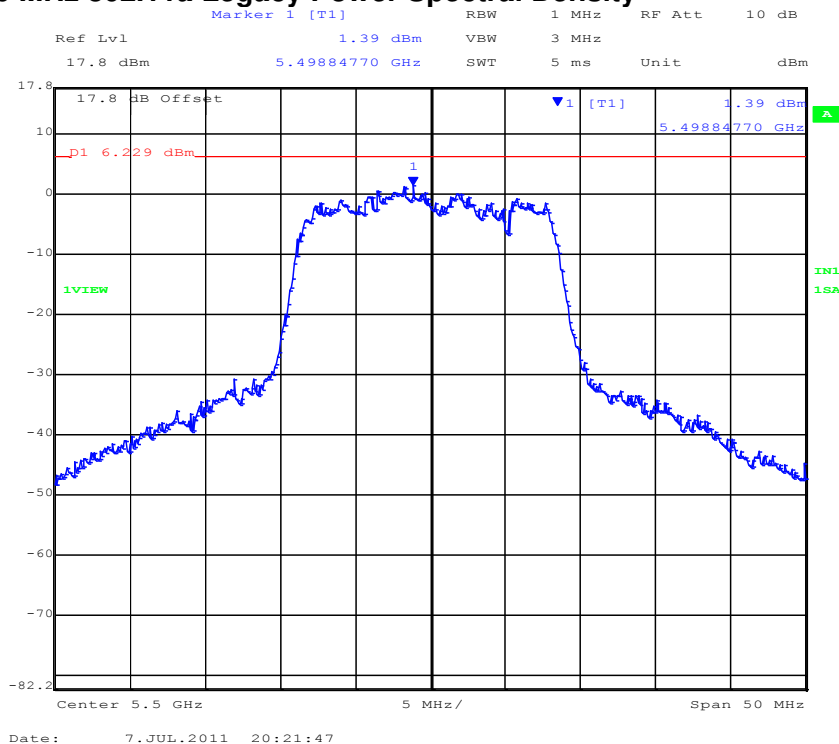

This test report may be reproduced in full only. The document may only be updated by MiCOM Labs personnel. Any changes will be noted in the Document History section of the report.



Title: NetScout Systems Inc. SENSOR4 Product Family
To: FCC 47 CFR Part 15.407 & IC RSS-247
Serial #: NTCT77-U3 Rev A
Issue Date: 12th December 2016
Page: 145 of 269

PORT C 5,500 MHz 802.11a Legacy Power Spectral Density

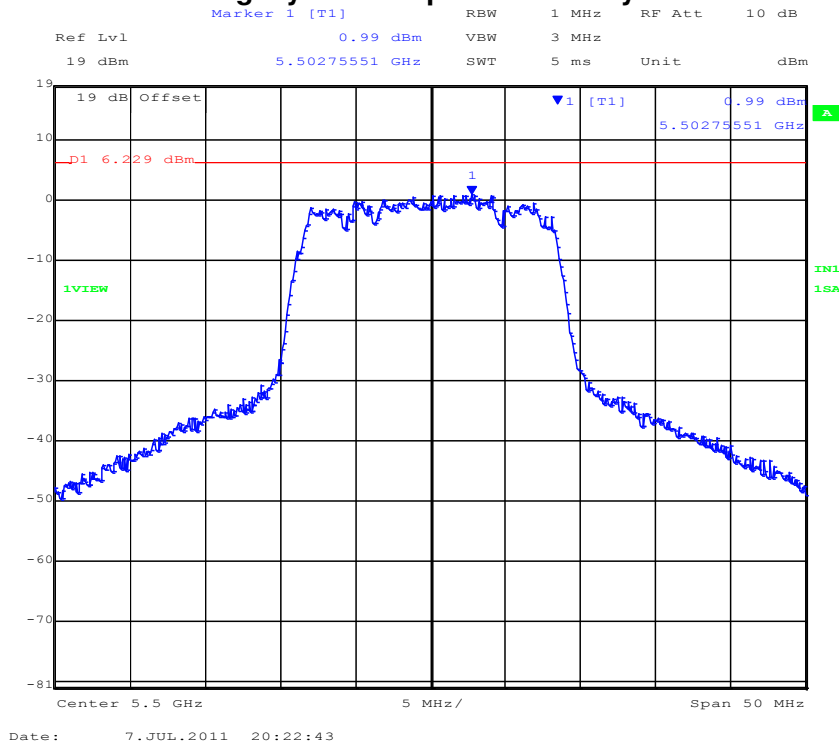

PORT A 5,580 MHz 802.11a Legacy Power Spectral Density

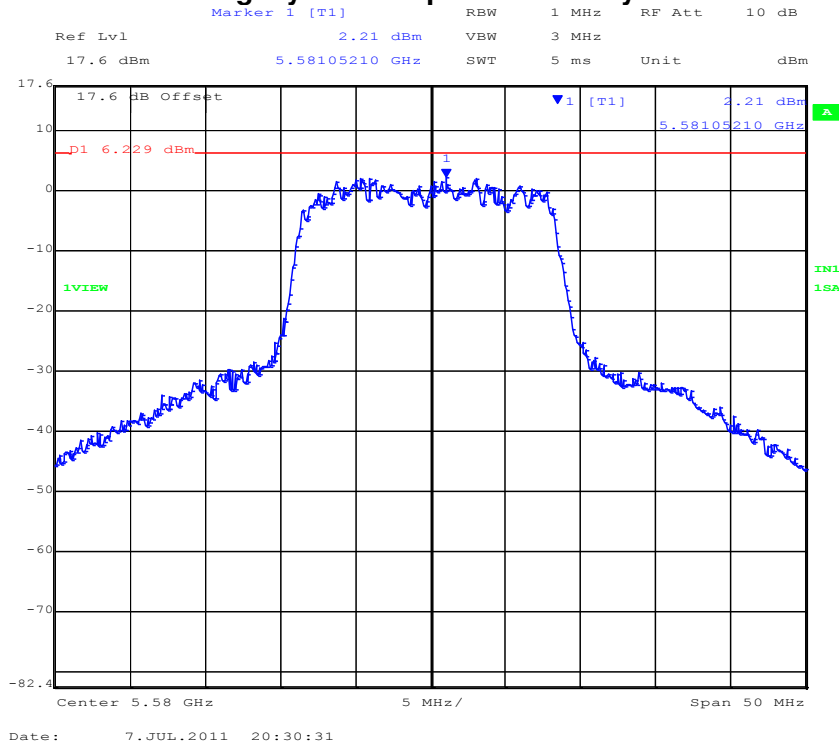

This test report may be reproduced in full only. The document may only be updated by MiCOM Labs personnel. Any changes will be noted in the Document History section of the report.



Title: NetScout Systems Inc. SENSOR4 Product Family
To: FCC 47 CFR Part 15.407 & IC RSS-247
Serial #: NTCT77-U3 Rev A
Issue Date: 12th December 2016
Page: 146 of 269

PORT B 5,580 MHz 802.11a Legacy Power Spectral Density

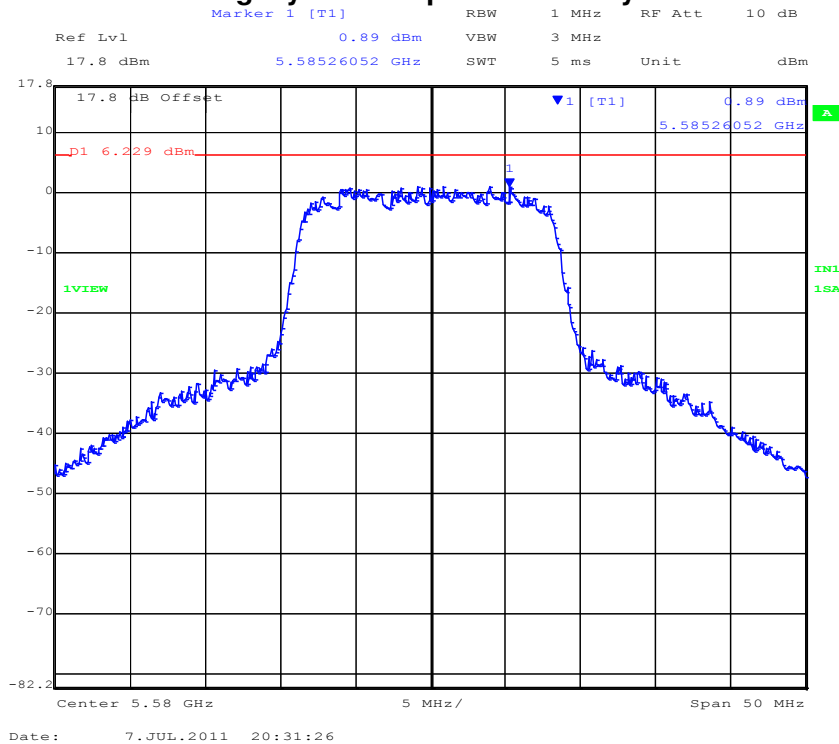

PORT C 5,580 MHz 802.11a Legacy Power Spectral Density

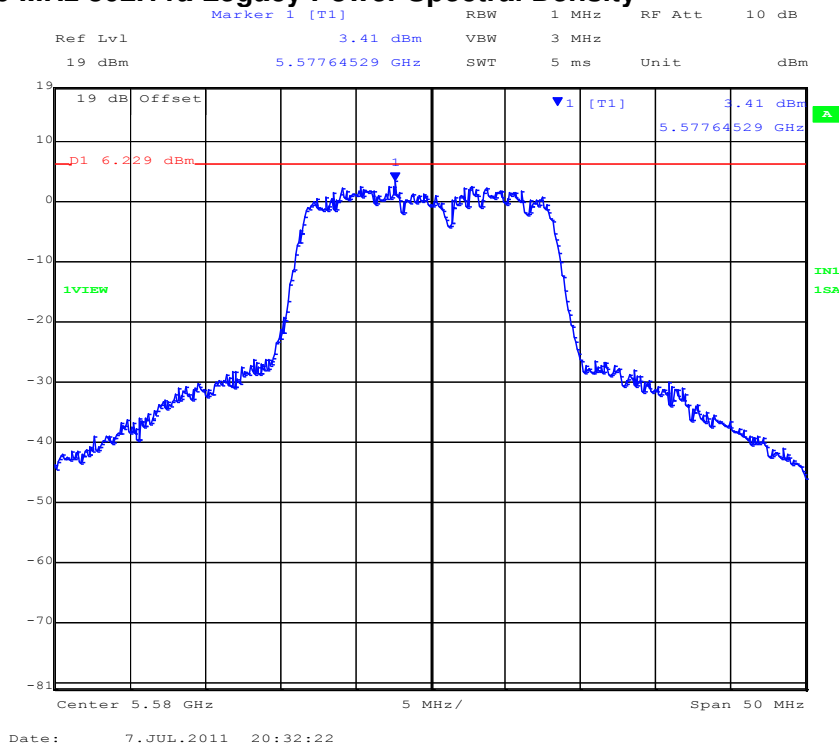

This test report may be reproduced in full only. The document may only be updated by MiCOM Labs personnel. Any changes will be noted in the Document History section of the report.



Title: NetScout Systems Inc. SENSOR4 Product Family
To: FCC 47 CFR Part 15.407 & IC RSS-247
Serial #: NTCT77-U3 Rev A
Issue Date: 12th December 2016
Page: 147 of 269

PORT A 5,700 MHz 802.11a Legacy Power Spectral Density

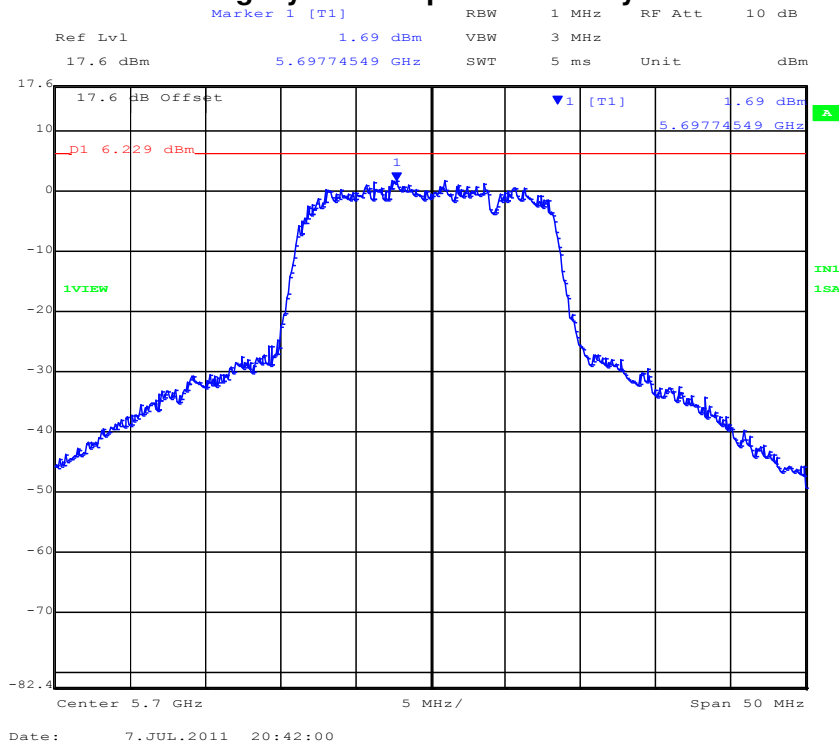

PORT B 5,700 MHz 802.11a Legacy Power Spectral Density

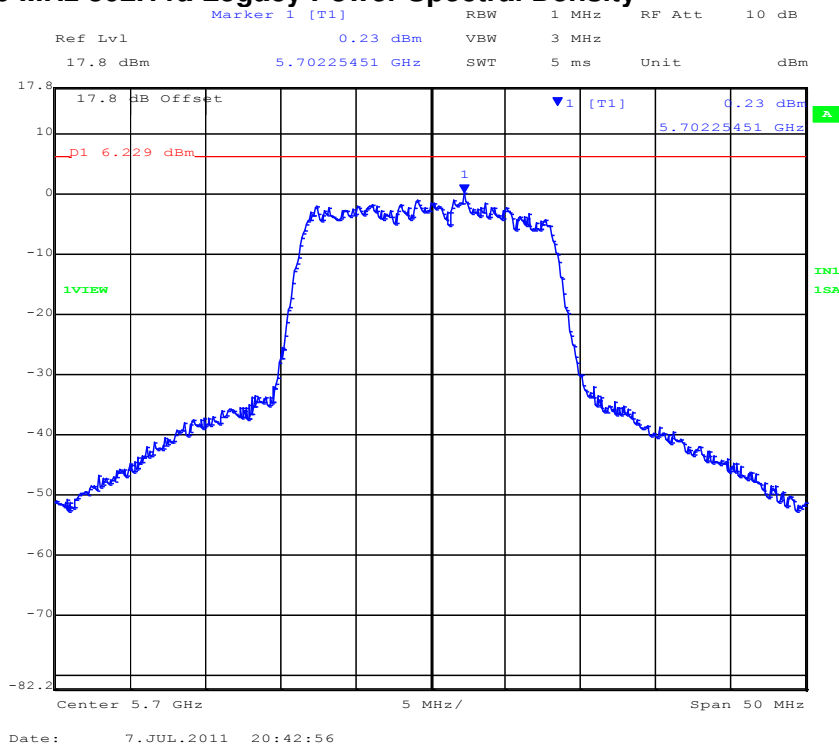

This test report may be reproduced in full only. The document may only be updated by MiCOM Labs personnel. Any changes will be noted in the Document History section of the report.



PORT C 5,700 MHz 802.11a Legacy Power Spectral Density

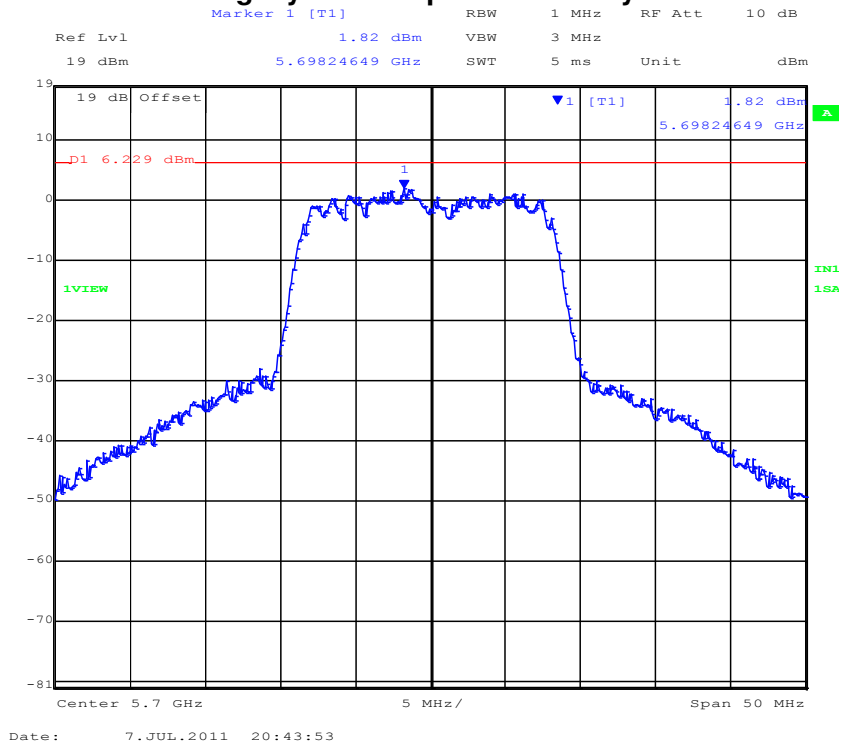

This test report may be reproduced in full only. The document may only be updated by MiCOM Labs personnel. Any changes will be noted in the Document History section of the report.



Title: NetScout Systems Inc. SENSOR4 Product Family
To: FCC 47 CFR Part 15.407 & IC RSS-247
Serial #: NTCT77-U3 Rev A
Issue Date: 12th December 2016
Page: 149 of 269

TABLE OF RESULTS – 802.11n HT-20 5500 - 5700 MHz

Test Conditions:	15.407 (a)	Rel. Humidity (%):	35	to	42
Variant:	802.11n HT-20	Ambient Temp. (°C):	19	to	22
TPC:	HIGH	Pressure (mBars):	998	to	1003
Modulation:	ON	Duty Cycle (%):	100		
Beam Forming Gain (Y):	N/A dB	Antenna Gain:	0 dBi		
Applied Voltage:	48.0 Vdc	Antenna Ports (N):	3		
Notes 1:					
Notes 2:					

Test Frequency	Measured Peak Power				Correction factor	Peak Power Spectral Density	Limit	Margin
	RF Port (dBm)							
MHz	a	b	c	d	10Log(N)	dBm	dBm	dB
5500.00	2.07	0.72	1.66	--	4.77	6.84	11.00	-4.16
5580.00	2.03	1.04	3.05	--	4.77	7.82	11.00	-3.18
5700.00	0.74	-1.89	2.00	--	4.77	6.78	11.00	-4.22

Measurement uncertainty:	±1.33 dB
---------------------------------	----------

This test report may be reproduced in full only. The document may only be updated by MiCOM Labs personnel. Any changes will be noted in the Document History section of the report.



Title: NetScout Systems Inc. SENSOR4 Product Family
To: FCC 47 CFR Part 15.407 & IC RSS-247
Serial #: NTCT77-U3 Rev A
Issue Date: 12th December 2016
Page: 150 of 269

PORT A 5,500 MHz 802.11n HT-20 Power Spectral Density

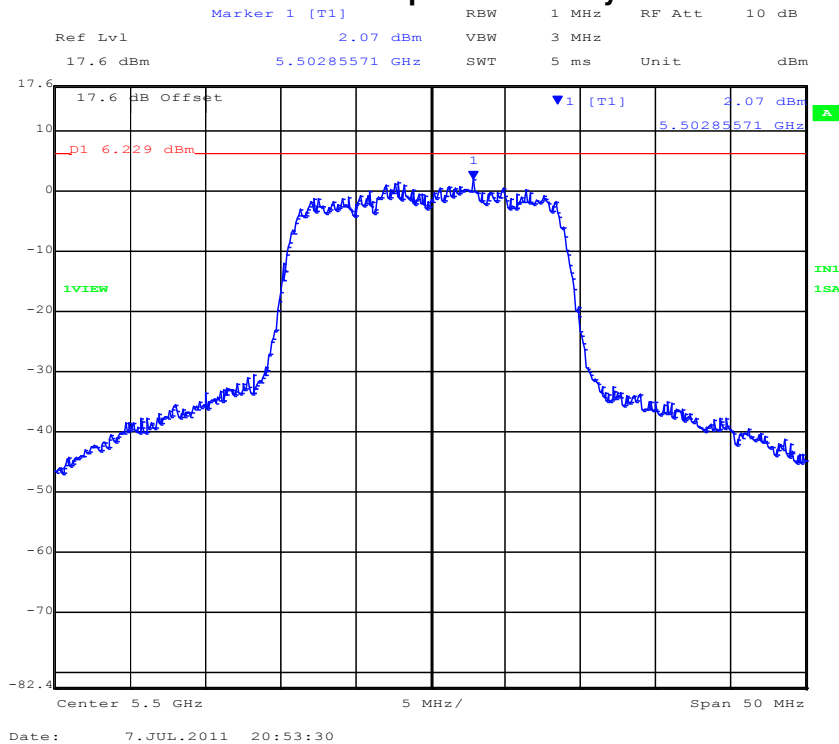

PORT B 5,500 MHz 802.11n HT-20 Power Spectral Density

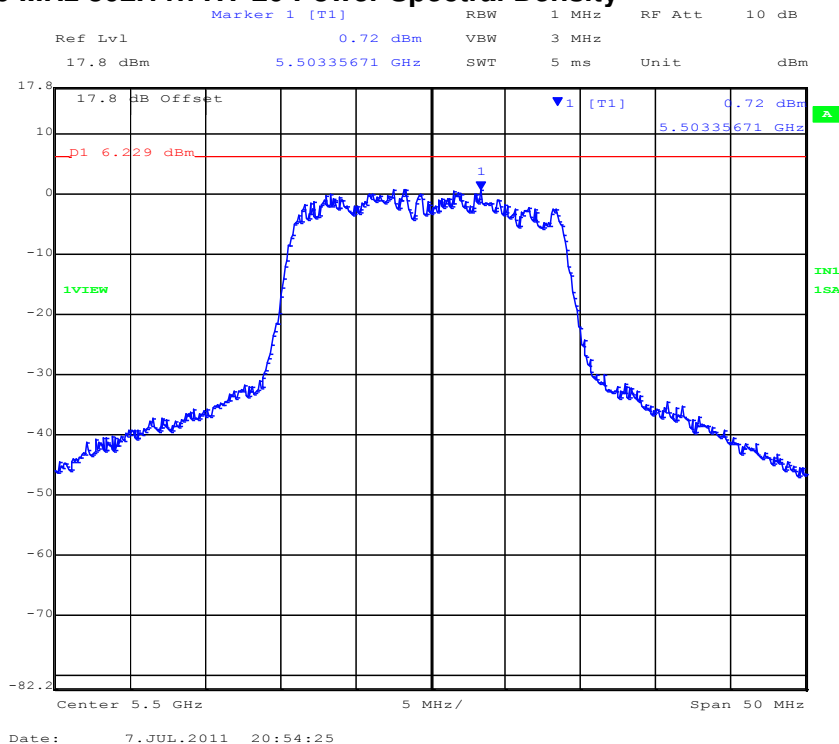

This test report may be reproduced in full only. The document may only be updated by MiCOM Labs personnel. Any changes will be noted in the Document History section of the report.



PORT C 5,500 MHz 802.11n HT-20 Power Spectral Density

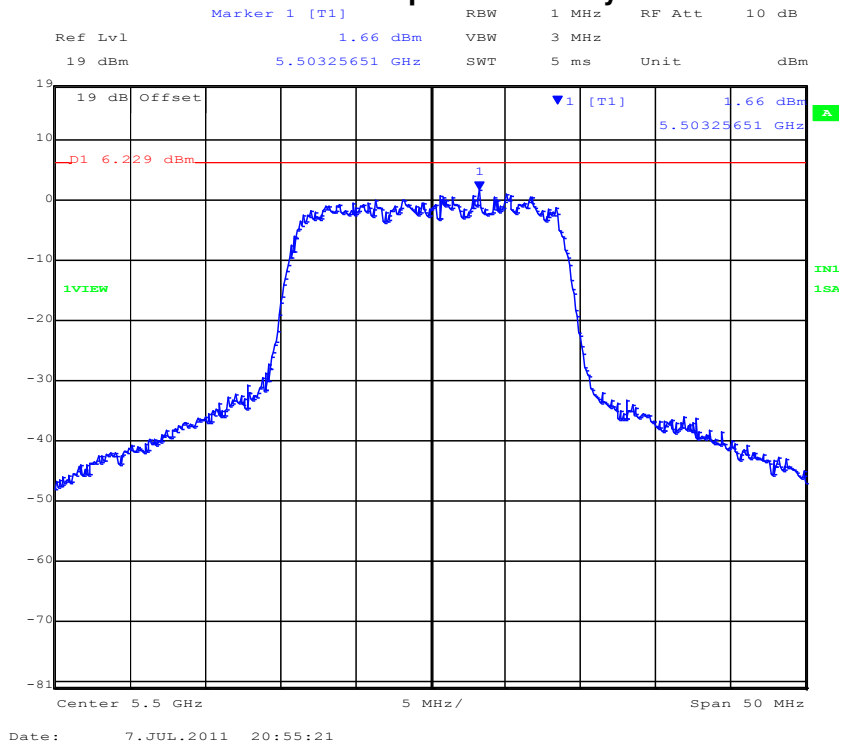

PORT A 5,580 MHz 802.11n HT-20 Power Spectral Density

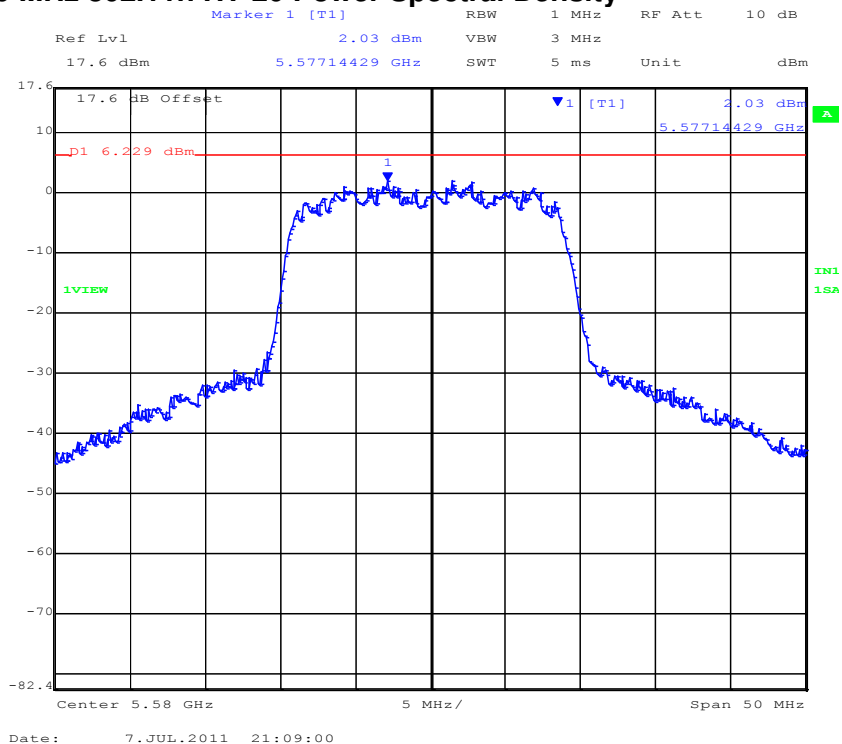

This test report may be reproduced in full only. The document may only be updated by MiCOM Labs personnel. Any changes will be noted in the Document History section of the report.



Title: NetScout Systems Inc. SENSOR4 Product Family
To: FCC 47 CFR Part 15.407 & IC RSS-247
Serial #: NTCT77-U3 Rev A
Issue Date: 12th December 2016
Page: 152 of 269

PORT B 5,580 MHz 802.11n HT-20 Power Spectral Density

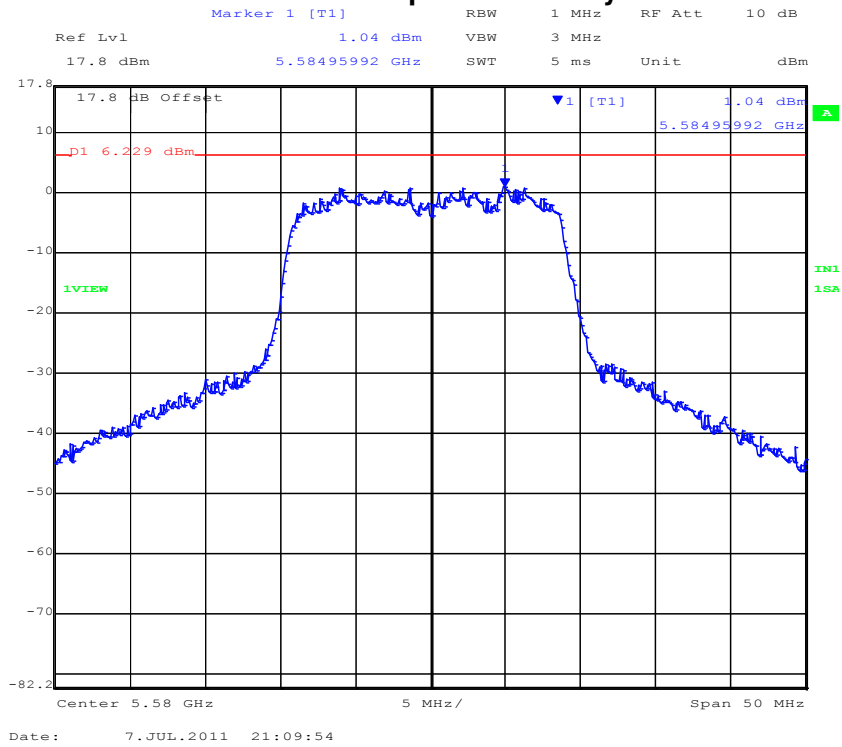

PORT C 5,580 MHz 802.11n HT-20 Power Spectral Density

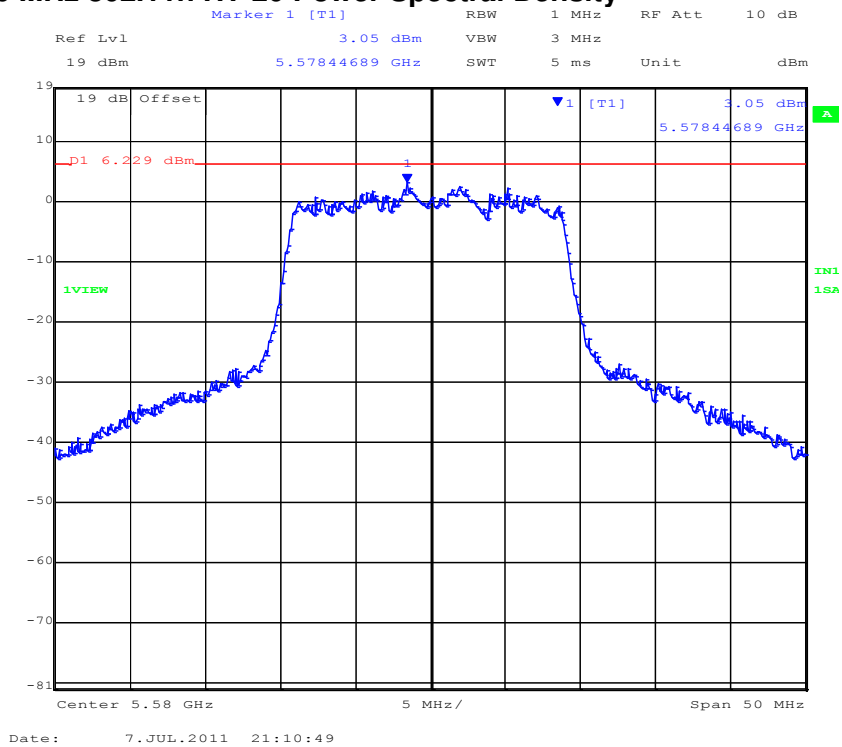

This test report may be reproduced in full only. The document may only be updated by MiCOM Labs personnel. Any changes will be noted in the Document History section of the report.



Title: NetScout Systems Inc. SENSOR4 Product Family
To: FCC 47 CFR Part 15.407 & IC RSS-247
Serial #: NTCT77-U3 Rev A
Issue Date: 12th December 2016
Page: 153 of 269

PORT A 5,700 MHz 802.11n HT-20 Power Spectral Density

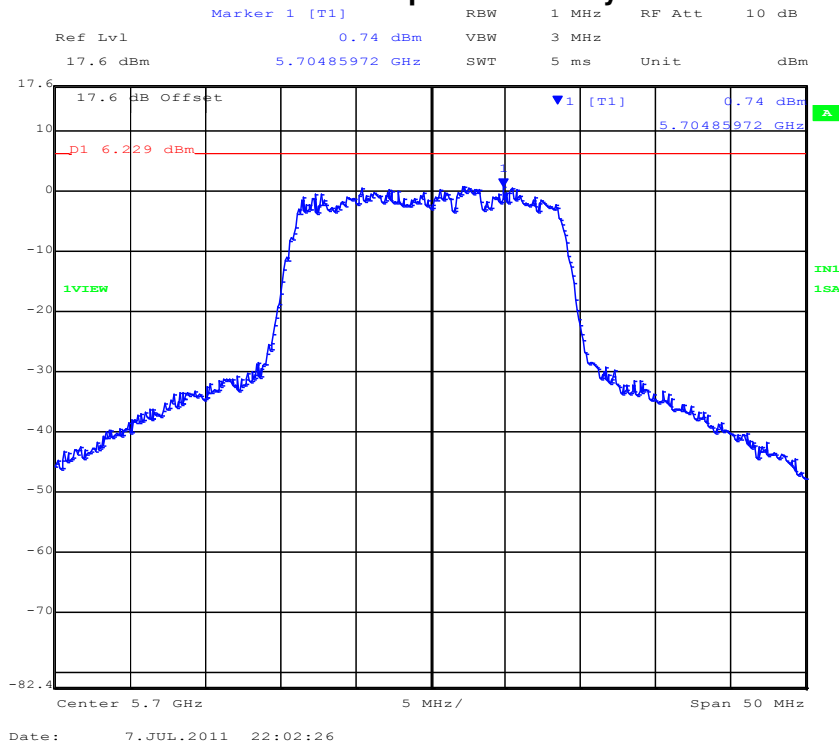

PORT B 5,700 MHz 802.11n HT-20 Power Spectral Density

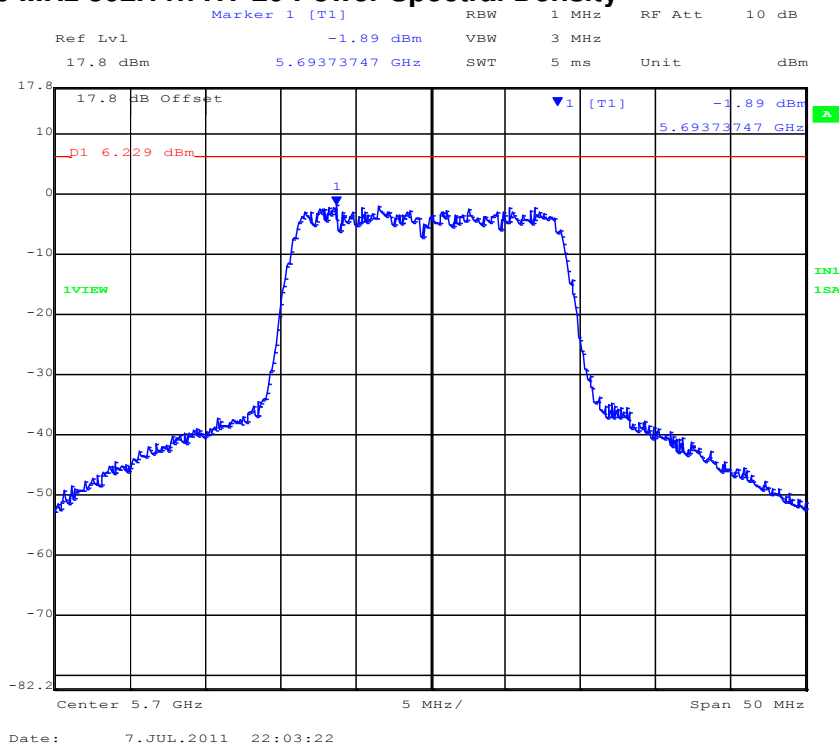

This test report may be reproduced in full only. The document may only be updated by MiCOM Labs personnel. Any changes will be noted in the Document History section of the report.



Title: NetScout Systems Inc. SENSOR4 Product Family
To: FCC 47 CFR Part 15.407 & IC RSS-247
Serial #: NTCT77-U3 Rev A
Issue Date: 12th December 2016
Page: 154 of 269

PORT C 5,700 MHz 802.11n HT-20 Power Spectral Density

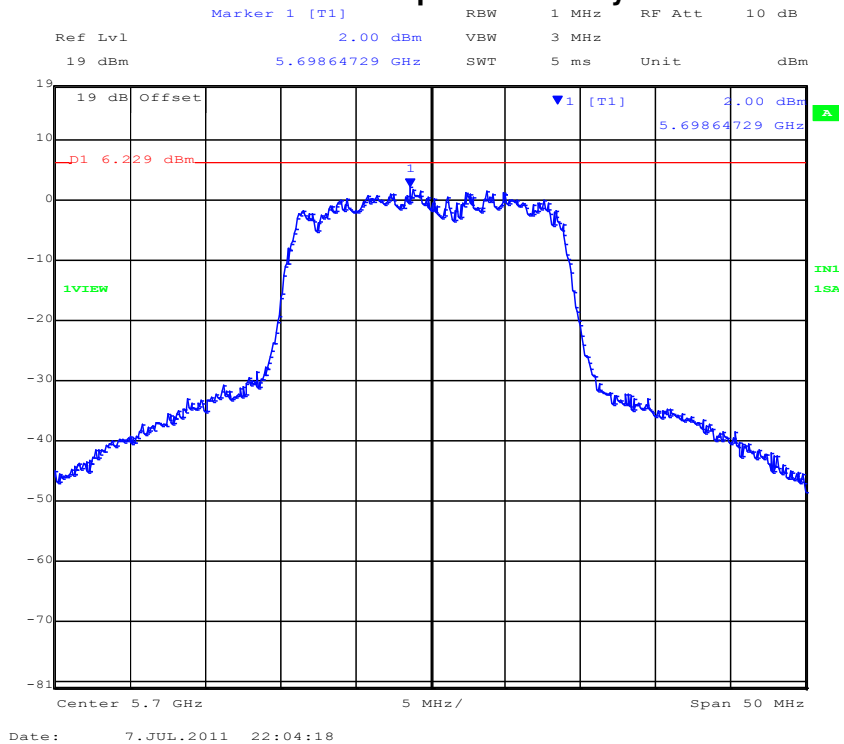

This test report may be reproduced in full only. The document may only be updated by MiCOM Labs personnel. Any changes will be noted in the Document History section of the report.



Title: NetScout Systems Inc. SENSOR4 Product Family
To: FCC 47 CFR Part 15.407 & IC RSS-247
Serial #: NTCT77-U3 Rev A
Issue Date: 12th December 2016
Page: 155 of 269

TABLE OF RESULTS – 802.11n HT-40 5500 - 5700 MHz

Test Conditions:	15.407 (a)	Rel. Humidity (%):	35	to	42
Variant:	802.11n HT-40	Ambient Temp. (°C):	19	to	22
TPC:	HIGH	Pressure (mBars):	998	to	1003
Modulation:	ON	Duty Cycle (%):	100		
Beam Forming Gain (Y):	N/A dB	Antenna Gain:	0 dBi		
Applied Voltage:	48.0 Vdc	Antenna Ports (N):	3		
Notes 1:					
Notes 2:					

Test Frequency	Measured Peak Power				Correction factor	Peak Power Spectral Density	Limit	Margin
	RF Port (dBm)							
MHz	a	b	c	d	10Log(N)	dBm	dBm	dB
5510.00	-2.23	-3.65	-2.79	--	4.77	2.54	11.00	-8.46
5550.00	-2.01	-2.69	-1.51	--	4.77	3.27	11.00	-7.73
5670.00	-3.01	-4.75	-1.70	--	4.77	3.07	11.00	-7.93

Measurement uncertainty:	±1.33 dB
---------------------------------	----------

This test report may be reproduced in full only. The document may only be updated by MiCOM Labs personnel. Any changes will be noted in the Document History section of the report.



Title: NetScout Systems Inc. SENSOR4 Product Family
To: FCC 47 CFR Part 15.407 & IC RSS-247
Serial #: NTCT77-U3 Rev A
Issue Date: 12th December 2016
Page: 156 of 269

PORT A 5,510 MHz 802.11n HT-40 Power Spectral Density

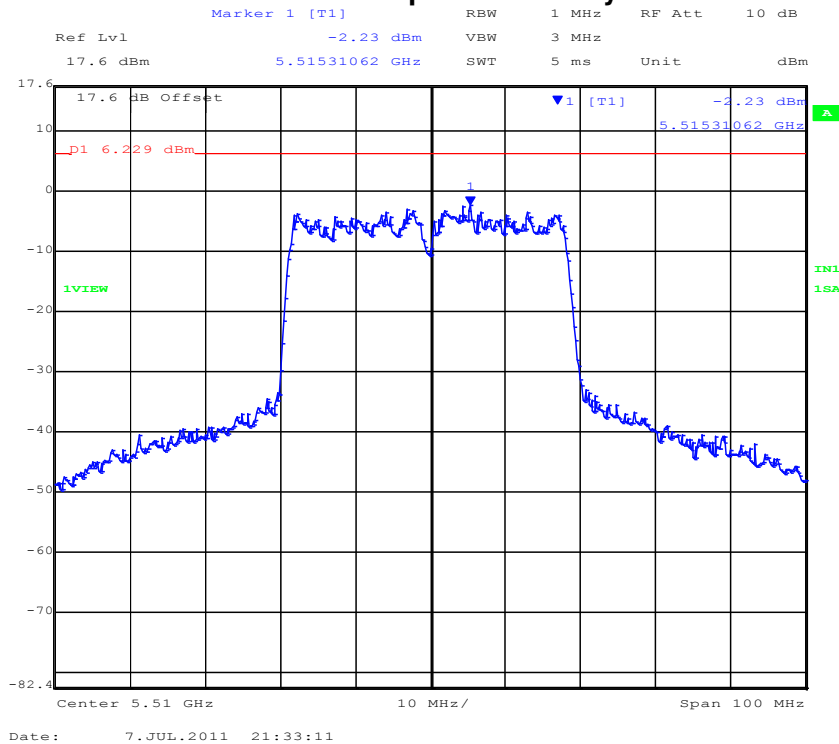

PORT B 5,510 MHz 802.11n HT-40 Power Spectral Density

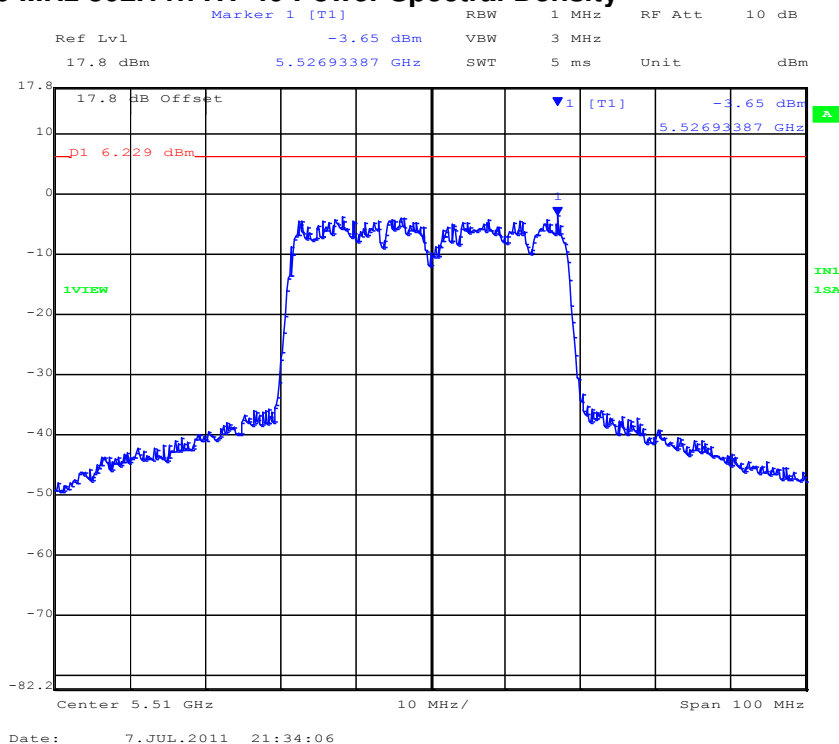

This test report may be reproduced in full only. The document may only be updated by MiCOM Labs personnel. Any changes will be noted in the Document History section of the report.



PORT C 5,510 MHz 802.11n HT-40 Power Spectral Density

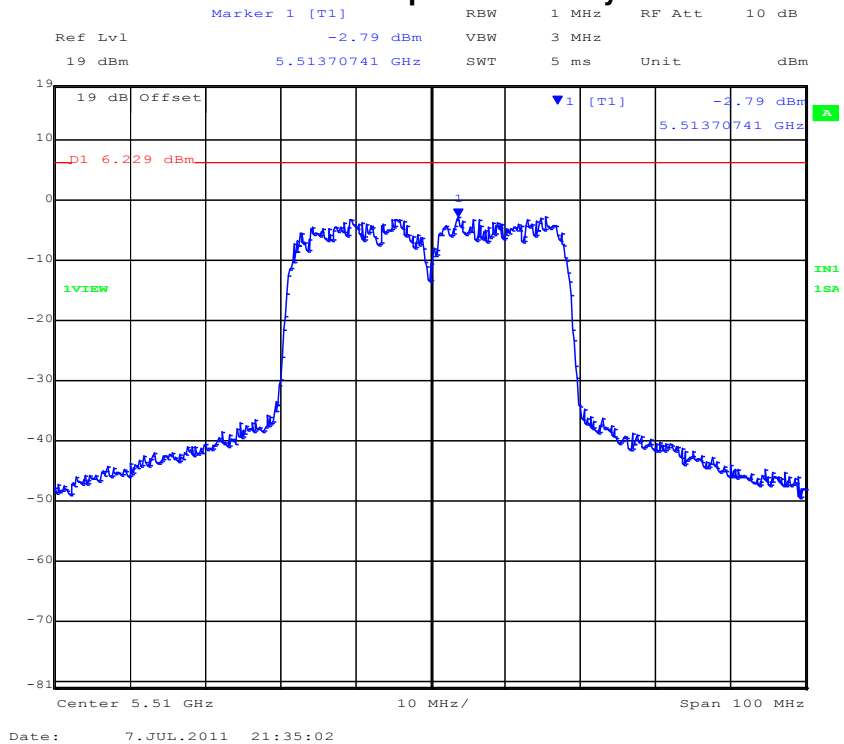

PORT A 5,500 MHz 802.11n HT-40 Power Spectral Density

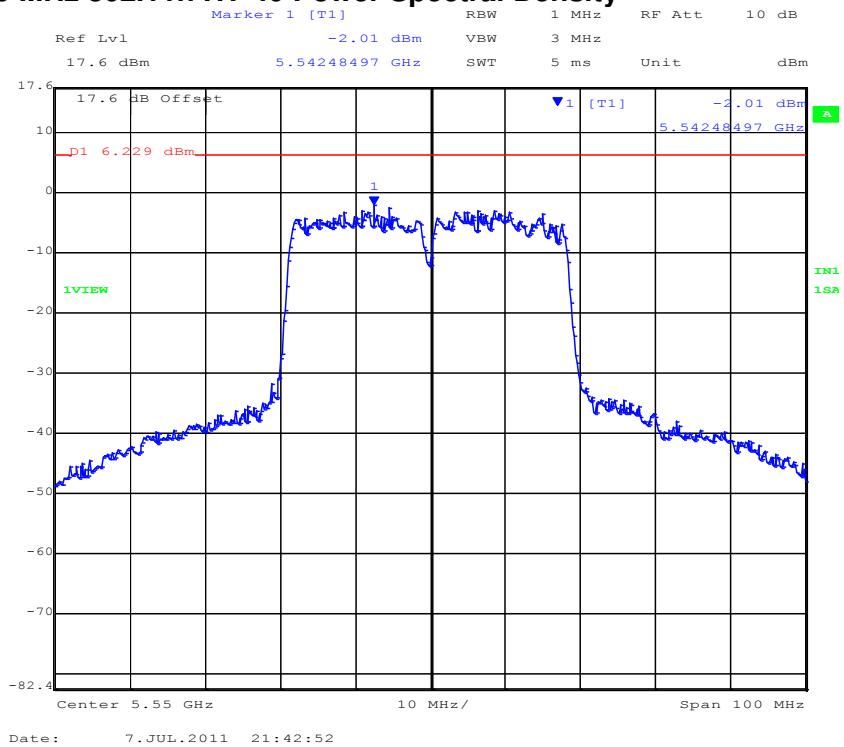

This test report may be reproduced in full only. The document may only be updated by MiCOM Labs personnel. Any changes will be noted in the Document History section of the report.



PORT B 5,550 MHz 802.11n HT-40 Power Spectral Density

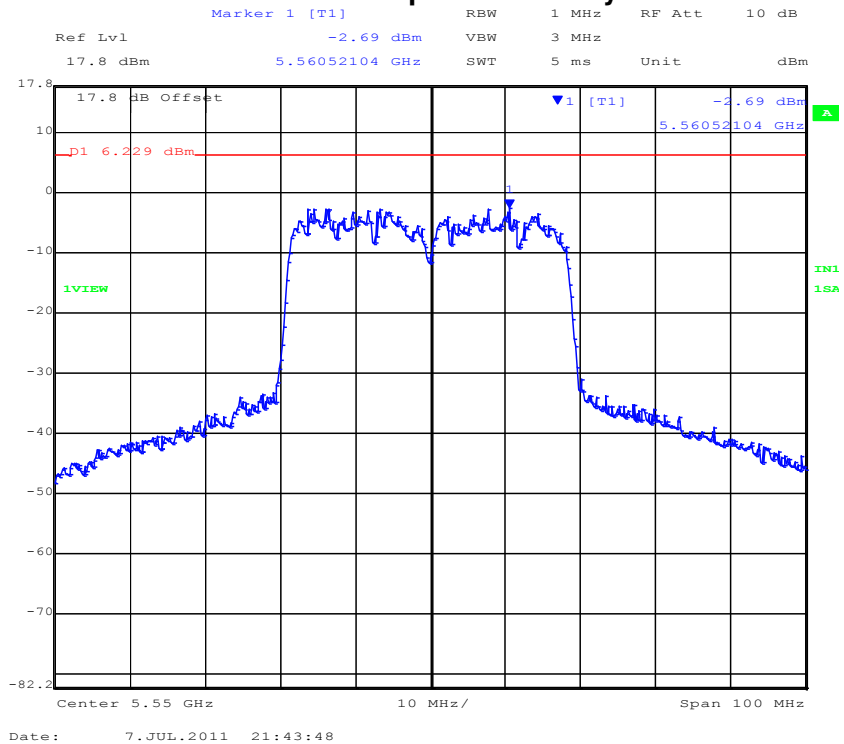

PORT C 5,550 MHz 802.11n HT-40 Power Spectral Density

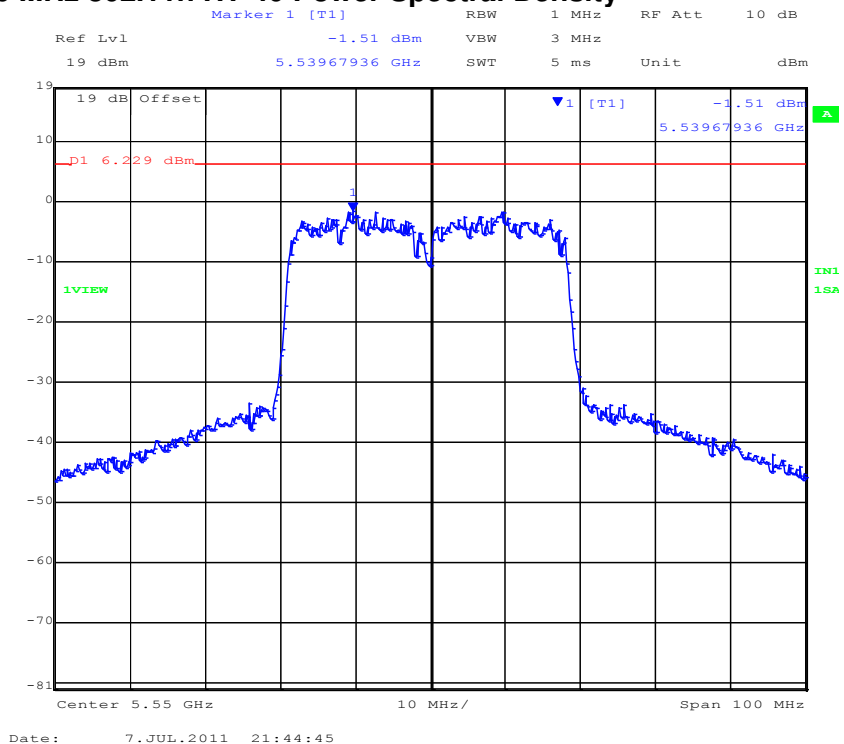

This test report may be reproduced in full only. The document may only be updated by MiCOM Labs personnel. Any changes will be noted in the Document History section of the report.



Title: NetScout Systems Inc. SENSOR4 Product Family
To: FCC 47 CFR Part 15.407 & IC RSS-247
Serial #: NTCT77-U3 Rev A
Issue Date: 12th December 2016
Page: 159 of 269

PORT A 5,690 MHz 802.11n HT-40 Power Spectral Density

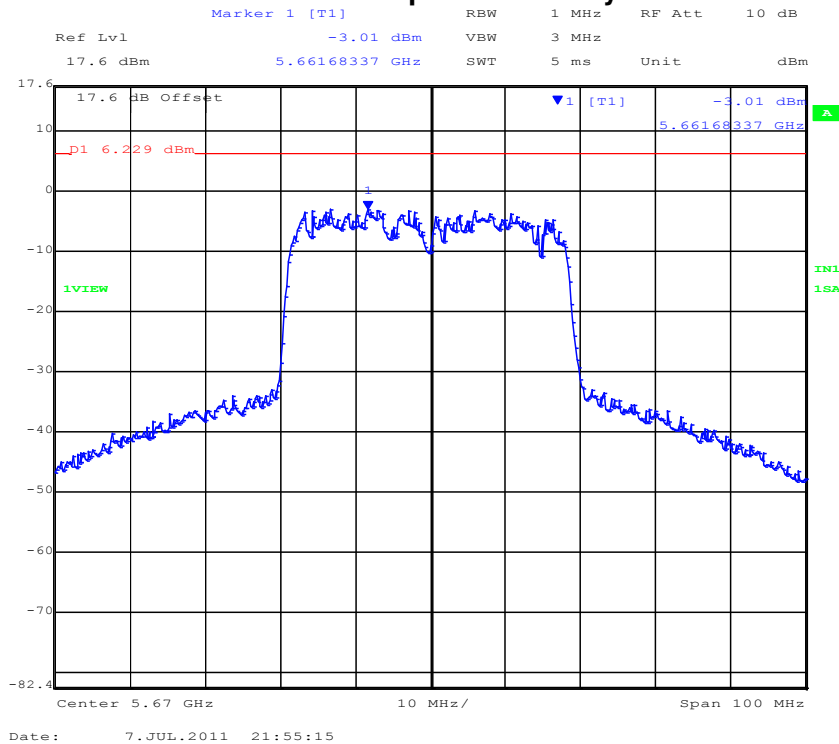

PORT B 5,690 MHz 802.11n HT-40 Power Spectral Density

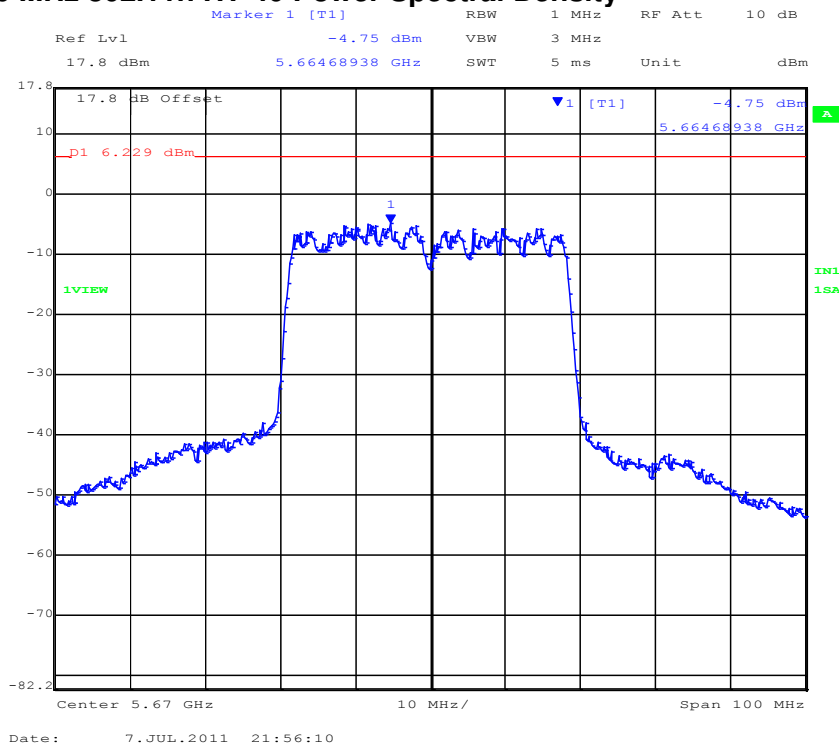

This test report may be reproduced in full only. The document may only be updated by MiCOM Labs personnel. Any changes will be noted in the Document History section of the report.



PORT C 5,690 MHz 802.11n HT-40 Power Spectral Density

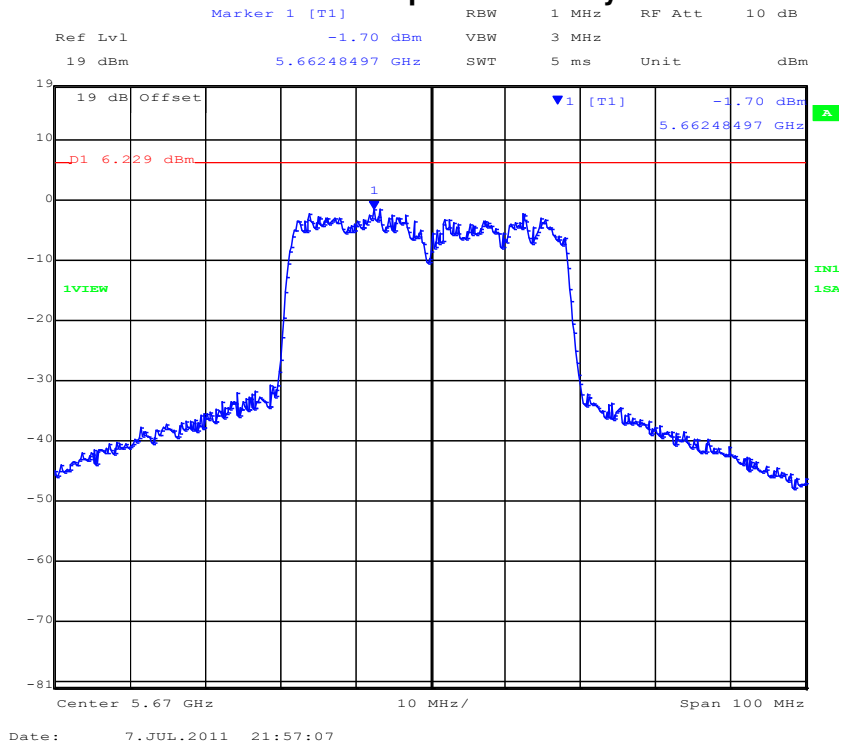

This test report may be reproduced in full only. The document may only be updated by MiCOM Labs personnel. Any changes will be noted in the Document History section of the report.



Title: NetScout Systems Inc. SENSOR4 Product Family
To: FCC 47 CFR Part 15.407 & IC RSS-247
Serial #: NTCT77-U3 Rev A
Issue Date: 12th December 2016
Page: 161 of 269

Laboratory Measurement Uncertainty for Spectral Density

Measurement uncertainty	± 1.33 dB
-------------------------	---------------

This test report may be reproduced in full only. The document may only be updated by MiCOM Labs personnel. Any changes will be noted in the Document History section of the report.



Title: NetScout Systems Inc. SENSOR4 Product Family
To: FCC 47 CFR Part 15.407 & IC RSS-247
Serial #: NTCT77-U3 Rev A
Issue Date: 12th December 2016
Page: 162 of 269

5.1.4. Frequency Stability

FCC, Part 15 Subpart C §15.407(g)

Test Procedure

The manufacturer of the equipment is responsible for ensuring that the frequency stability is such that emissions are always maintained within the band of operation under all conditions.

Manufacturer Declaration

The frequency stability of the reference oscillator sets the frequency stability of the RF transceiver signals. Therefore all of the RF signals should have ± 20 ppm stability.

This stability accounts for room temp tolerance of the crystal oscillator circuit, frequency variation across temperature, and crystal ageing.

± 20 ppm at 5.250 GHz translates to a maximum frequency shift of ± 105 KHz. As the edge of the channels is at least one MHz from either of the band edges, ± 105 KHz is more than sufficient to guarantee that the intentional emission will remain in the band over the entire operating range of the EUT.

Specification

Limits

§15.407 (g) Manufacturers of U-NII devices are responsible for ensuring frequency stability such that an emission is maintained within the band of operation under all conditions of normal operation as specified in the user's manual.

This test report may be reproduced in full only. The document may only be updated by MiCOM Labs personnel. Any changes will be noted in the Document History section of the report.