

RF Test Report

Applicant : Getac Technology Corporation

Product Name : NFC Module

Trade Name : Getac

Model Number : ZX80 PN7160 NFC Module

Applicable Standard : FCC 47 CFR PART 15 SUBPART C
ANSI C63.10:2013

Received Date : Oct. 31, 2023

Test Period : Mar. 06, 2024 ~ Mar. 11, 2024

Issued Date : Apr. 01, 2024

Issued by

Eurofins E&E Wireless Taiwan Co., Ltd.
No. 140-1, Changan Street, Bade District,
Taoyuan City 334025, Taiwan (R.O.C.)
Tel : +886-3-2710188 / Fax : +886-3-2710190



Taiwan Accreditation Foundation accreditation number: 1330
Frequency Range: 9 kHz to 325 GHz
Bade test site :
Test Firm Registration Number: 226252
Test Firm Designation Number: TW0010
Wugu test site :
Test Firm Registration Number: 191812
Test Firm Designation Number: TW0034

Note:

1. The test results are valid only for samples provided by customers and under the test conditions described in this report.
2. This report shall not be reproduced except in full, without the written approval of Eurofins E&E Wireless Taiwan Co., Ltd.
3. The relevant information is provided by customers in this test report. According to the correctness, appropriateness or completeness of the information provided by the customer, if there is any doubt or error in the information which affects the validity of the test results, the laboratory does not take the responsibility.

Revision History

Rev.	Issued Date	Description	Revised by
00	Apr. 01, 2024	Initial Issue	Abby Huang

Verification of Compliance

Applicant : Getac Technology Corporation

Product Name : NFC Module

Trade Name : Getac

Model Number : ZX80 PN7160 NFC Module

FCC ID : QYLPN7160ZX8

Applicable Standard : FCC 47 CFR PART 15 SUBPART C
ANSI C63.10:2013

Test Result : Complied

Performing Lab. : Eurofins E&E Wireless Taiwan Co., Ltd.
No. 140-1, Changan Street, Bade District,
Taoyuan City 334025, Taiwan (R.O.C.)
Tel : +886-3-2710188 / Fax : +886-3-2710190
Taiwan Accreditation Foundation accreditation number: 1330



Eurofins E&E Wireless Taiwan Co., Ltd. tested the above equipment in accordance with the requirements set forth in the above standards. All indications of Pass/Fail in this report are opinions expressed by Eurofins E&E Wireless Taiwan Co., Ltd. based on interpretations and/or observations of test results. The test results show that the equipment tested is capable of demonstrating compliance with the requirements as documented in this report.

Approved By : _____

TABLE OF CONTENTS

1	General Information	5
1.1.	Summary of Test Result.....	5
1.2.	Testing Location.....	6
1.3.	Measurement Uncertainty.....	6
1.4.	Test Site Environment.....	6
2	EUT Description	7
3	Test Methodology	8
3.1.	Mode of Operation	8
3.2.	EUT Test Step.....	8
3.3.	Configuration of Test System Details	9
3.4.	Test Instruments	10
4	Measurement Procedure	12
4.1.	AC Power Line Conducted Emission Measurement	12
4.2.	Radiated Emission Measurement	14
4.3.	Frequency Stability Measurement	17
4.4.	20 dB Bandwidth Measurement.....	18
4.5.	Antenna Requirement.....	19
5	Test Results	20
5.1.	Conducted Emission.....	20
5.2.	Conducted Test Results.....	22
5.3.	Radiated Emission Measurement.....	24

Appendix A. Test Setup Photographs

1 General Information

1.1. Summary of Test Result

Standard	Item	Results	Remark
15.203	Antenna Requirement	Meet Require	---
15.207(a)	Conducted Emissions Voltage	PASS	---
15.225 (a), (b), (c), (d) 15.209	Radiated Emission Limits	PASS	---
15.225(e)	Frequency Stability	PASS	---
15.215(c)	20 dB Bandwidth	-----	---
CFR 47 Part 15.225 / ANSI C63.10:2013			

Standard	Description
CFR47, Part 15, Subpart C	Intentional Radiators
ANSI C63. 10: 2013	American National Standard of Procedures for Compliance Testing of Unlicensed Wireless Devices

Decision Rule

- Uncertainty is not included.
- Uncertainty is included.

1.2. Testing Location

Lab Name: Eurofins E&E Wireless Taiwan Co., Ltd.
 Site Address: No. 140-1, Changan Street, Bade District, Taoyuan City 334025, Taiwan (R.O.C.)
 Site Address: No. 2, Wuquan 5th Rd. Wugu Dist., New Taipei City, Taiwan (R.O.C.)

1.3. Measurement Uncertainty

Test Item	Frequency	Uncertainty			
		BD		WG	
Conducted Emission	150 kHz ~ 30 MHz	2.7 dB		2.6 dB	
RF Bandwidth		4.5 %		4.5 %	
Frequency Stability		1.3 x 10 ⁻⁷		1.3 x 10 ⁻⁷	
Test Item	Frequency	Uncertainty			
		96601-BD	96603-BD	96602-WG	96603-WG
Radiated Emission	9 kHz ~ 30 MHz	1.9 dB	1.9 dB	1.6 dB	1.6 dB
	30 MHz ~ 1000 MHz	4.9 dB	4.9 dB	4.8 dB	4.8 dB
	1000 MHz ~ 18000 MHz	4.9 dB	5.0 dB	5.0 dB	5.2 dB
	18000 MHz ~ 26500 MHz	4.3 dB	4.4 dB	4.4 dB	4.5 dB
	26500 MHz ~ 40000 MHz	4.5 dB	4.5 dB	4.6 dB	4.5 dB

1.4. Test Site Environment

Items	Required (IEC 60068-1)	Interval(*)
Temperature (°C)	15-35	20-30
Humidity (%RH)	25-75	45-75

(*)The measurement ambient temperature is within this range.

2 EUT Description

The product specifications of the EUT presented in the report are declared by the manufacturer who shall take full responsibility for the authenticity

Applicant	Getac Technology Corporation 5F., Building A, No. 209, Sec. 1, Nangang Rd., Nangang Dist., Taipei City, 115018, Taiwan
Product Name	NFC Module
Trade Name	Getac
Model Number	ZX80 PN7160 NFC Module
FCC ID	QYLPN7160ZX8
Host Information	Product Name: Tablet Trade Name: Getac Model Name: ZX80, ZX80Y(Y= 10 characters, Y can be 0 to 9, A to Z, a to z, "/", "\", "-", "_" or blank for marketing purpose) (All models are electrically identical, different model names are for marketing purpose.)
Frequency Range	13.56 MHz
Modulation Type	PSK
Number of Channels	1 Channel
Antenna Type	Loop Antenna
Operate Temp. Range	-10 ~ +50°C
EUT Power Rating	DC 3.3 V

Note : All measurements were performed radiated and therefore additional antenna gain is not required.

3 Test Methodology

3.1. Mode of Operation

The following test mode(s) were scanned during the preliminary test :

Test Mode
Transmit Mode
Continuous TX mode

Eurofins has verified the construction and function in typical operation. All the test modes were carried out with the EUT in normal operation.

The device used two models of adapter, adapter number: A20-065N3A is worst case to perform testing.

3.2. EUT Test Step

1.	Setup the EUT shown on "Configuration of Test System Details."
2.	Turn on the power of all equipment.
3.	The EUT will start to operate function.

3.3. Configuration of Test System Details

Conduction Emission & Radiated Emissions (Below 1 GHz)

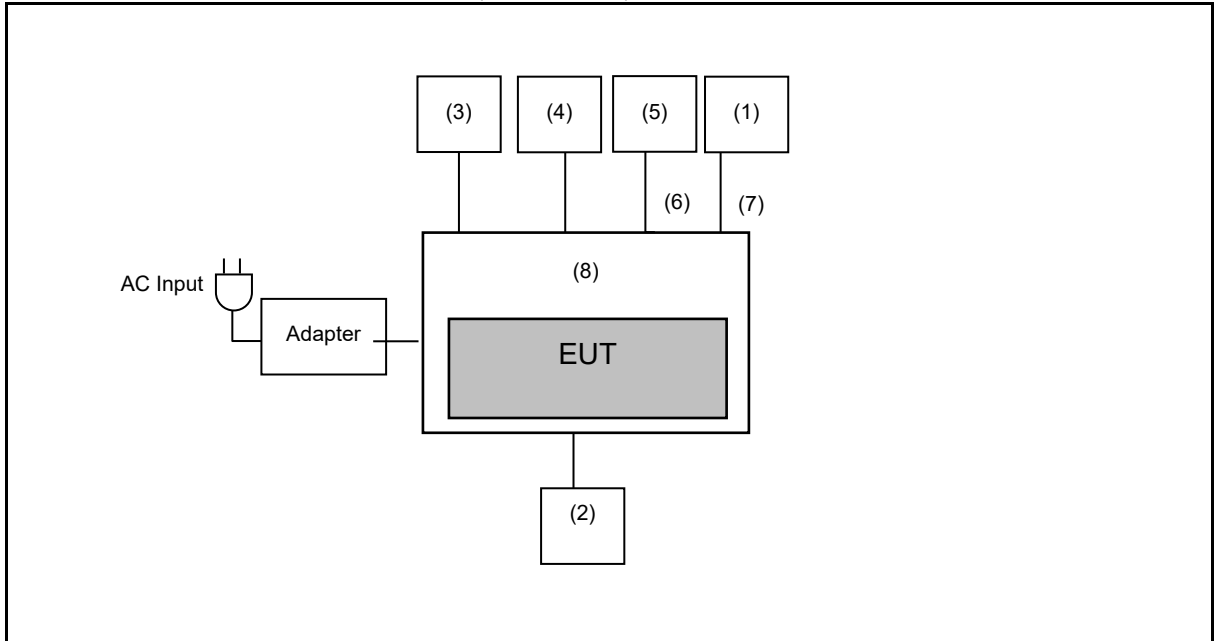

Devices Description					
	Product	Manufacturer	Model Number	Serial Number	Power Cord
(1)	Notebook	DELL	P137G	---	---
(2)	Earphone	APPLE	MNHF2FE/A	---	---
(3)	Keyboard	DELL	KB4021	---	---
(4)	Mouse	ASUS	YACHT	---	---
(5)	Monitor	ASUS	PA279	---	---
(6)	HDMI Cable	I-gota	CH2-WD018	---	---
(7)	Lan Cable	Tatung	CAT5e	---	---
(8)	Office Dock	Getac	ZX80 Office Dock	---	---

3.4. Test Instruments

For Conducted

Test Period: Mar. 06, 2024

Testing Engineer: Sandy Yang

Test Site		RF03-WG				
Use	Equipment	Manufacturer	Model Number	Serial Number	Cal. Date	Cal. Period
<input checked="" type="checkbox"/>	Spectrum Analyzer (10 Hz~44 GHz)	R&S	FSV3044	101255	Nov. 30, 2023	1 year
<input checked="" type="checkbox"/>	Temperature & Humidity Chamber	GiantForce	GTH-408-40-CP-SD	MAA2202-001	Jan. 03, 2024	1 year
<input checked="" type="checkbox"/>	Power Supply	RIGOL	DP711	DP7A243601513	Nov. 16, 2023	1 year

For Radiated Emissions

Test Period: Mar. 08, 2024 ~ Mar. 11, 2024

Testing Engineer: Jason Yeh

Radiation test sites		Semi Anechoic Room 96603-WG				
Use	Equipment	Manufacturer	Model Number	Serial Number	Cal. Date	Cal. Period
<input checked="" type="checkbox"/>	LOOP Antenna (9 kHz~30 MHz)	Schwarzbeck Mess-Elektronik	FMZB 1513-60	00031	Feb. 23, 2024	1 year
<input checked="" type="checkbox"/>	Trilog Broadband Antenna (30 kHz~1 GHz)	Schwarzbeck Mess-Elektronik	VULB9168	1276	Feb. 02, 2024	1 year
<input checked="" type="checkbox"/>	Spectrum Analyzer (2 Hz~50 GHz)	KEYSIGHT	N9030B	MY57153537	Apr. 18, 2023	1 year
<input checked="" type="checkbox"/>	Pre-Amplifier	EMCI	EMC001330	980859	Nov. 29, 2023	1 year
<input checked="" type="checkbox"/>	Coaxial Cable (10 kHz~3000 MHz)	EMCI	EMCCFD400-NM-NM-2000	211009	Dec. 28, 2023	1 year
<input checked="" type="checkbox"/>	Coaxial Cable (10 kHz~3000 MHz)	EMCI	EMCCFD400-NM-NM-2000	211010	Dec. 28, 2023	1 year
<input checked="" type="checkbox"/>	Coaxial Cable (10 kHz~3000 MHz)	EMCI	EMCCFD400-NM-NM-6000	211018	Dec. 28, 2023	1 year
<input checked="" type="checkbox"/>	Software	R_RAM	V1.3	N/A	N.C.R.	---

Note: N.C.R. = No Calibration Request.

For Conduction Emissions

Test Period: Mar. 08, 2024

Testing Engineer: Jason Yeh

Radiation test sites		Conducted Emission Measurement Conduction01-WG				
Use	Equipment	Manufacturer	Model Number	Serial Number	Cal. Date	Cal. Period
<input checked="" type="checkbox"/>	Test Receiver	R&S	ESR3	102919	Dec 30, 2023	1 year
<input checked="" type="checkbox"/>	LISN	R&S	ENV216	101041	Apr 12, 2023	1 year
<input checked="" type="checkbox"/>	ISN	R&S	ENY81-CA6	101948	Dec 01, 2023	1 year
<input checked="" type="checkbox"/>	Current Probe	R&S	EZ-17	101687	Jun 15, 2023	1 year
<input checked="" type="checkbox"/>	Cable	EMCI	EMCCFD300-BM-NM-4000	220402	Jun 08, 2023	1 year
<input checked="" type="checkbox"/>	Software	ELEKTRA	94.50.4	N.A.	N.C.R.	N.C.R.

Note: N.C.R. = No Calibration Request.

4 Measurement Procedure

4.1. AC Power Line Conducted Emission Measurement

■ Limit

Frequency (MHz)	Quasi-peak	Average
0.15 - 0.5	66 to 56	56 to 46
0.50 - 5.0	56	46
5.0 - 30.0	60	50

■ Test Setup

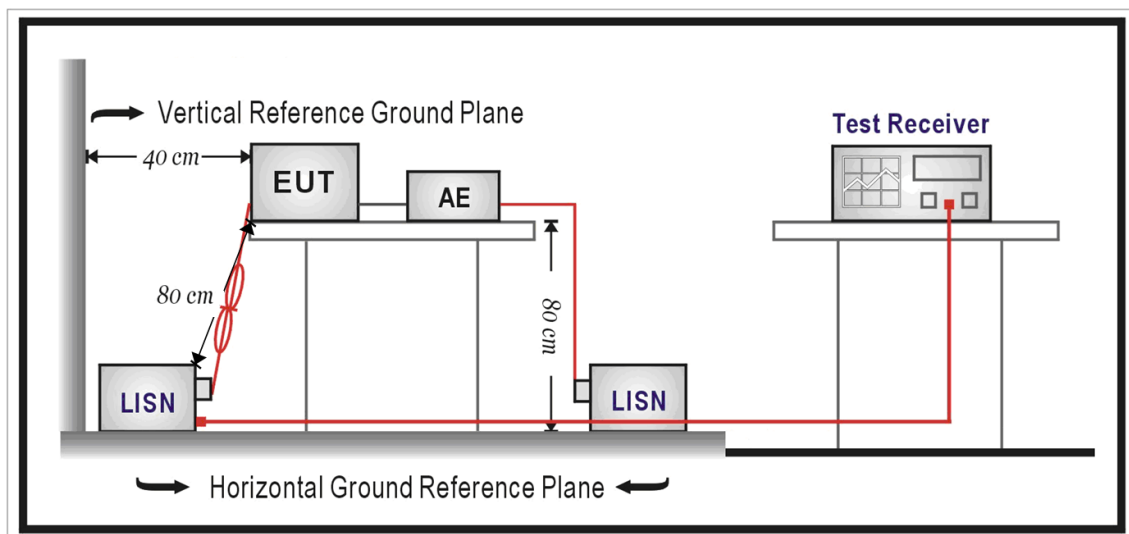

■ Test Procedure

The EUT and simulators are connected to the main power through a line impedance stabilization network (L.I.S.N.). This provides a $50 \Omega // 50 \mu\text{H}$ coupling impedance for the measuring equipment. The peripheral devices are also connected to the main power through a LISN that provides a $50 \Omega // 50 \mu\text{H}$ coupling impedance with 50 ohm termination.

Tabletop device shall be placed on a non-conducting platform, of nominal size 1 m by 1.5 m, raised 80 cm above the reference ground plane. The wall of screened room shall be located 40 cm to the rear of the EUT. Other surfaces of tabletop or floor standing EUT shall be at least 80 cm from any other ground conducting surface including one or more LISNs. For floor-standing device shall be placed under the EUT with a 12 mm insulating material.

Conducted emissions were investigated over the frequency range from 0.15 MHz to 30 MHz using a resolution bandwidth of 9 kHz. The equipment under test (EUT) shall be meet the limits in section 4.1, as applicable, including the average limit and the quasi-peak limit when using respectively, an average detector and quasi-peak detector measured in accordance with the methods described of related standard. When all of peak value were complied with quasi-peak and average limit from 150 kHz to 30 MHz then quasi-peak and average measurement was unnecessary.

The AMN shall be placed 0.8 m from the boundary of the unit under test and bonded to a ground reference plane for AMNs mounted on top of the ground reference plane. This distance is between the closest points of the AMN and the EUT. All other units of the EUT and associated equipment shall be at least 0.8 m from the AMN. If the mains power cable is longer than 1 m then the cable shall be folded back and forth at the centre of the lead to form a bundle no longer than 0.4 m. All of interconnecting cables that hang closer than 40 cm to the ground plane shall be folded back and forth in the center forming a bundle 30 cm to 40 cm long. All of EUT and AE shall be separate place more than 0.1 m. All 50 Ω ports of the LISN shall be resistively terminated into 50 Ω loads when not connected to the measuring instrument.

If the reading of the measuring receiver shows fluctuations close to the limit, the reading shall be observed for at least 15 s at each measurement frequency; the higher reading shall be recorded with the exception of any brief isolated high reading which shall be ignored.

4.2. Radiated Emission Measurement

■ **Limit**

According to §15.225,

- (a) The field strength of any emissions within the band 13.553 – 13.567 MHz shall not exceed 15,848 microvolt / meter at 30 meters.
- (b) Within the bands 13.410 – 13.553 MHz and 13.567 -13.710 MHz, the field strength of any emissions shall not exceed 334 microvolt / meter at 30 meters.
- (c) Within the bands 13.110 – 13.410 MHz and 13.710 – 14.010 MHz the field strength of any emissions shall not exceed 106 microvolt / meter at 30 meters.
- (d) The field strength of any emissions appearing outside of the 13.110 – 14.010 MHz and shall not exceed the general radiated emission limits in §15.209.

According to §15.225(a), except as provided elsewhere in this Subpart, the emissions from an intentional radiator shall not exceed the field strength levels specified in the following table:

Frequency (MHz)	Field Strength (μ V/m at meter)	Measurement Distance (meter)
0.009 – 0.490	2400 / F (kHz)	300
0.490 – 1.705	24000 / F (kHz)	30
1.705 – 30.0	30	30
30 - 88	100**	3
88-216	150**	3
216-960	200**	3
Above 960	500	3

** Except as provided in paragraph (g), fundamental emissions from intentional radiators operating under this Section shall not be located in the frequency bands 54-72 MHz, 76-88 MHz, 174-216 MHz or 470-806 MHz. However, operation within these frequency bands is permitted under other sections of this Part, e.g., Sections 15.231 and 15.241.

■ Setup

9 kHz ~ 30 MHz

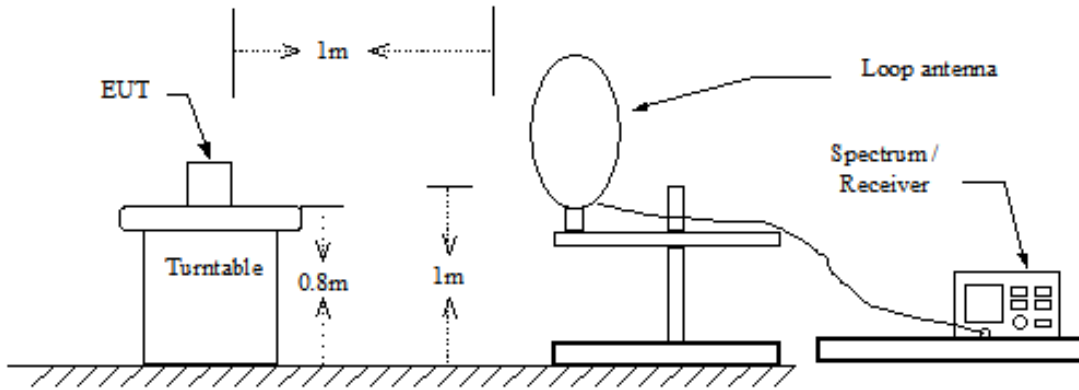

30 MHz ~ 1 GHz

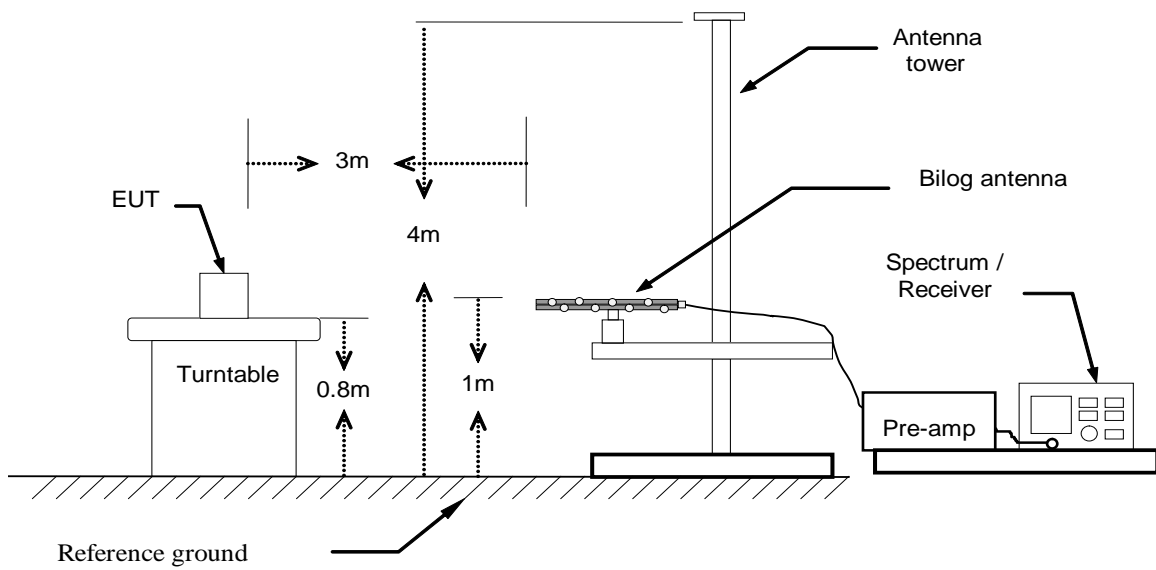

■ **Test Procedure**

Final radiation measurements were made on a three-meter Semi Anechoic Chamber. The EUT system was placed on a nonconductive turntable which is 0.8 meters height, top surface 1.0 x 1.5 meter. The spectrum was examined from 3 Hz to 44 GHz in order to cover the whole spectrum below 10th harmonic which could generate from the EUT. During the test, EUT was set to transmit continuously.

For measurements below 30 MHz the resolution bandwidth is set to 10 kHz for peak detection measurements or 9 kHz for quasi-peak detection measurements. The video bandwidth is 3 times of the resolution bandwidth.

For measurements below 1 GHz the resolution bandwidth is set to 100 kHz for peak detection measurements or 120 kHz for quasi-peak detection measurements. Peak detection is used unless otherwise noted as quasi-peak.

For measurements above 1 GHz the resolution bandwidth is set to 1 MHz, and then the video bandwidth is set to 3 MHz for peak measurements and 10 Hz for average measurements.

A nonconductive material surrounded the EUT to supporting the EUT for standing on three orthogonal planes. At each condition, the EUT was rotated 360 degrees, and the antenna was raised and lowered from one to four meters to find the maximum emission levels. Measurements were taken using both horizontal and vertical antenna polarization.

Broadband/Horn Antenna were used in frequency 30 MHz to 18 GHz at a distance of 3 meter. Loop/Horn Antenna was used in frequency 9 kHz to 30 MHz and 18 to 26.5 GHz at a distance of 1 meter. All test results were extrapolated to equivalent signal at 3 meters utilizing an inverse linear distance extrapolation Factor (20 dB/decade).

For testing above 1 GHz, the emission level of the EUT in peak mode was 20 dB lower than average limit (that means the emission level in peak mode also complies with the limit in average mode), then testing will be stopped and peak values of EUT will be reported, otherwise, the emissions will be measured in average mode again and reported.

Appropriate preamplifiers were used for improving sensitivity and precautions were taken to avoid overloading or desensitizing the spectrum analyzer. No post – detector video filters were used in the test.

The spectrum analyzer's 6 dB bandwidth was set to 1 MHz, and the analyzer was operated in the peak detection mode, for frequencies both below and up 1 GHz. The average levels were obtained by subtracting the duty cycle correction factor from the peak readings.

The following procedures were used to convert the emission levels measured in decibels referenced to 1 microvolt (dBuV) into field intensity in microvolt pre-meter (uV/m).

The actual field intensity in decibels referenced to 1 microvolt in to field intensity in microvolt per-meter (dBuV/m).

The actual field is intensity in referenced to 1 microvolt per meter (dBuV/m) is determined by algebraically adding the measured reading in dBuV, the antenna factor (dB), and cable loss (dB) and Subtracting the gain of preamplifier (dB) is auto calculate in spectrum analyzer.

(1) $Amplitude (dBuV/m) = FI (dBuV) + AF (dBuV) + CL (dBuV) - Gain (dB)$

FI= Reading of the field intensity.

AF= Antenna factor.

CL= Cable loss.

P.S Amplitude is auto calculate in spectrum analyzer.

(2) $Actual Amplitude (dBuV/m) = Amplitude (dBuV) - Dis(dB)$

The FCC specified emission limits were calculated according the EUT operating frequency and by following linear interpolation equations:

(a) For fundamental frequency : Transmitter Output < +30 dBm

(b) For spurious frequency : Spurious emission limits = fundamental emission limit /10

Data of measurement within this frequency range without mark in the table above means the reading of emissions are attenuated more than 20 dB below the permissible limits or the field strength is too small to be measured.

4.3. Frequency Stability Measurement

■ **Limit**

According to §15.207(e), the frequency tolerance of the carrier signal shall be maintained within +/- 0.01 % of the operating frequency over a temperature variation of -20 degrees to +50 degrees C at normal supply voltage, and for a variation in the primary supply voltage from 85 % to 115 % of the rated supply voltage at a temperature of 20 degrees C. For battery operated equipment, the equipment tests shall be performed using a new battery.

■ **Test Setup**

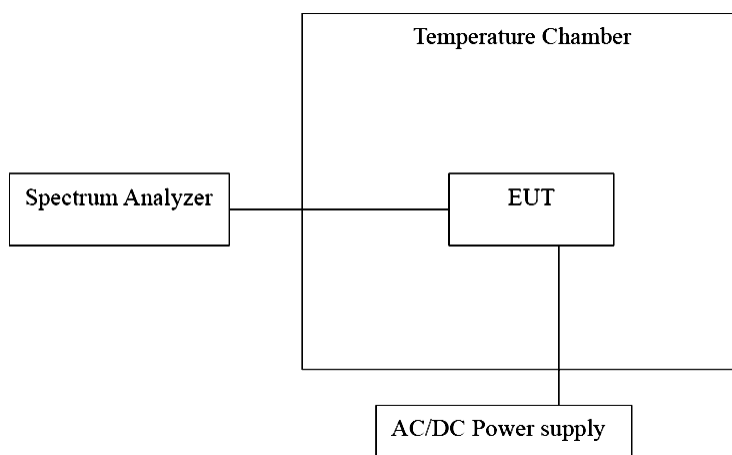

■ **Test Procedure**

1. Place the EUT on the table and set it in the transmitting mode.
2. Remove the antenna from the EUT and then connect a low loss RF cable from the antenna port to the spectrum analyzer.
3. Set the environment into appropriate environment.
4. Set the spectrum analyzer as RBW = 1 kHz, VBW = RBW, Span = 200 kHz, Sweep = auto.
5. Mark the peak frequency and measure the frequency tolerance using frequency counter function.
6. Repeat until all the results are investigated.

4.4. 20 dB Bandwidth Measurement

■ **Limit**

N/A

■ **Test Setup**

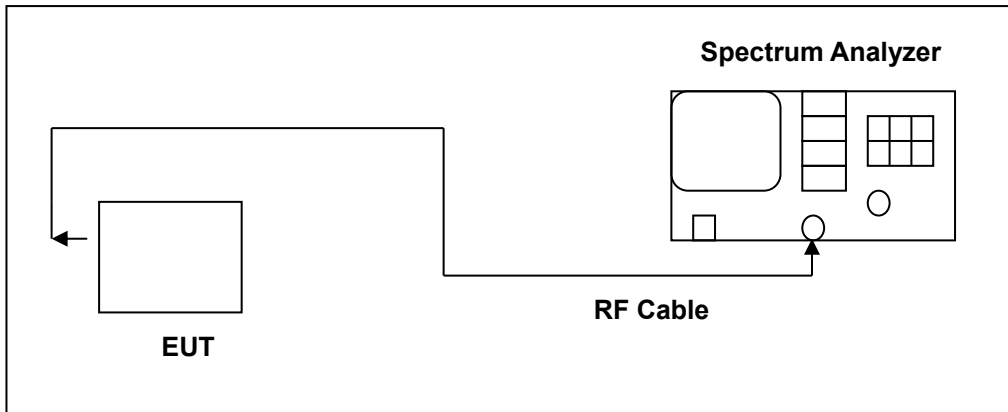

■ **Test Procedure**

Connect RF output port to the input of the spectrum analyzer. Connect the DUT to appropriate power supply. Turn RFID function of DUT on.

Analyzer used the following settings:

1. Span = 60 kHz
2. RBW \geq 1 % of the 20 dB span
3. VBW \geq RBW
4. Sweep = auto
5. Detector function = peak
6. Trace = max hold

The trace was allowed to stabilize. The EUT was transmitting at its maximum data rate. The marker-to-peak function was used to set the marker to the peak of the emission. The marker-delta function was used to measure 20 dB down one side of the emission. The marker-delta function and marker was moved to the other side of the emission until it was even with the reference marker. The marker-delta reading at this point was the 20 dB bandwidth of the emission.

4.5. Antenna Requirement

■ Require

An intentional radiator shall be designed to ensure that no antenna other than that furnished by the responsible party shall be used with the device. The use of a permanently attached antenna or of an antenna that uses a unique coupling to the intentional radiator shall be considered sufficient to comply with the provisions of this section. The manufacturer may design the unit so that a broken antenna can be replaced by the user, but the use of a standard antenna jack or electrical connector is prohibited.

■ Antenna Connector Construction

The antenna connector used in this product is internal antenna, cannot be replaced by the end-user.

See section 2 – antenna information.

5 Test Results

5.1. Conducted Emission

Standard:	FCC Part 15.225	Line:	L1
Test item:	Conducted Emission	Power:	AC 120 V/60 Hz
Mode:	Transmit Mode		
Description:			

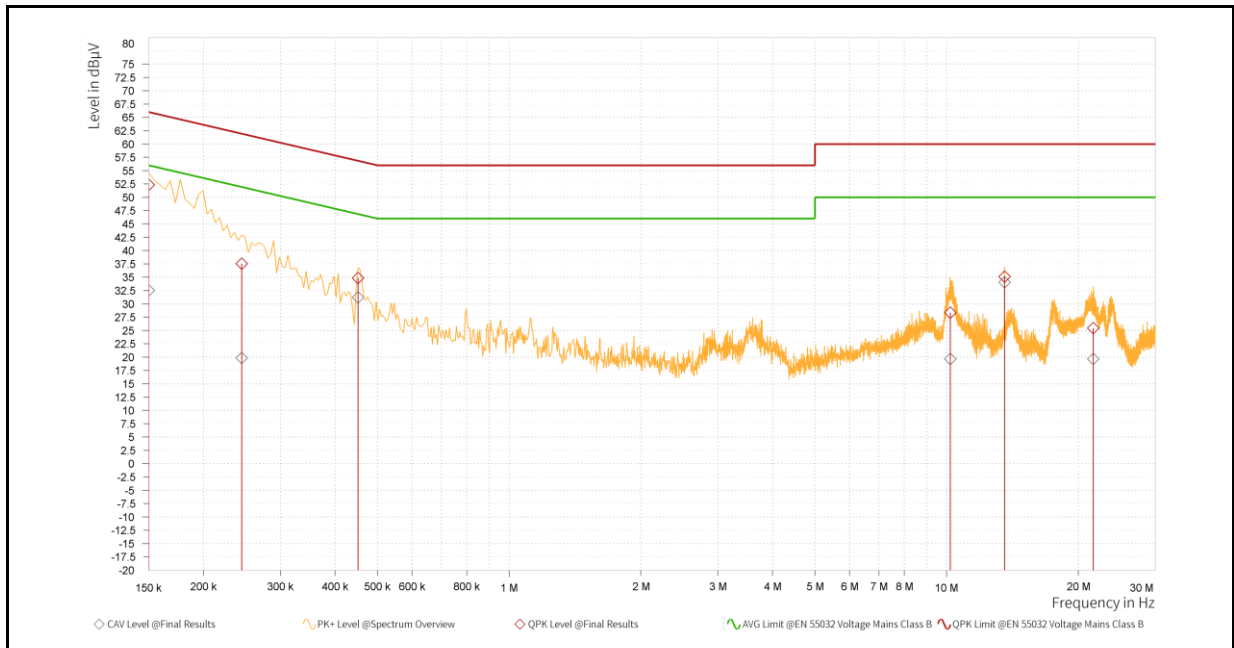

No.	Frequency (MHz)	QPK Level (dBuV)	QPK Limit (dBuV)	QPK Margin (dB)	CAV Level (dBuV)	CAV: AVG Limit (dBuV)	CAV Margin (dB)	Correction (dB)	Line
1	0.150	52.35	66.00	13.65	32.52	56.00	23.48	9.65	L1
1	0.245	37.53	61.94	24.41	19.82	51.94	32.12	9.64	L1
1	0.452	34.84	56.85	22.01	31.21	46.85	15.63	9.65	L1
1	10.199	28.34	60.00	31.66	19.67	50.00	30.33	9.92	L1
1	13.560	35.09	60.00	24.91	34.05	50.00	15.95	9.99	L1
1	21.633	25.45	60.00	34.55	19.67	50.00	30.33	10.11	L1

Note: 1. Result (dBuV) = Correction factor (dB) + Reading(dBuV).

2. Correction factor (dB) = Cable loss (dB) + L.I.S.N. factor (dB).

Standard:	FCC Part 15.225	Line:	N
Test item:	Conducted Emission	Power:	AC 120 V/60 Hz
Mode:	Transmit Mode		
Description:			



No.	Frequency (MHz)	QPK Level (dBuV)	QPK Limit (dBuV)	QPK Margin (dB)	CAV Level (dBuV)	CAV: AVG Limit (dBuV)	CAV Margin (dB)	Correction (dB)	Line
1	0.159	50.69	65.52	14.82	34.06	55.52	21.46	9.64	N
1	0.218	40.39	62.91	22.52	22.82	52.91	30.09	9.64	N
1	0.456	35.67	56.77	21.09	31.93	46.77	14.84	9.65	N
1	0.803	27.14	56.00	28.86	23.34	46.00	22.66	9.67	N
1	13.560	30.63	60.00	29.37	20.63	50.00	29.37	10.06	N
1	22.641	25.43	60.00	34.57	19.60	50.00	30.40	10.25	N

Note: 1. Result (dBuV) = Correction factor (dB) + Reading(dBuV).

2. Correction factor (dB) = Cable loss (dB) + L.I.S.N. factor (dB).

5.2. Conducted Test Results

Frequency Stability Measurement

Temperature Variations

Test Mode		Continuous TX Mode					
Temp. (°C)	Voltage (VAC)	0 minute Frequency Tolerance (%)	2 minutes Frequency Tolerance (%)	5 minutes Frequency Tolerance (%)	10 minutes Frequency Tolerance (%)	Limit (%)	Result (Pass/Fail)
-20	V _{Nom}	-0.0002	-0.0002	-0.0002	-0.0002	±0.01	Pass
-10	V _{Nom}	-0.0001	-0.0001	-0.0001	-0.0001	±0.01	Pass
0	V _{Nom}	-0.0001	-0.0001	-0.0001	-0.0001	±0.01	Pass
10	V _{Nom}	0.0009	0.0009	0.0009	0.0009	±0.01	Pass
20	V _{Nom}	0.0004	0.0004	0.0004	0.0004	±0.01	Pass
30	V _{Nom}	0.0010	0.0010	0.0010	0.0010	±0.01	Pass
40	V _{Nom}	0.0011	0.0011	0.0011	0.0011	±0.01	Pass
50	V _{Nom}	0.0011	0.0011	0.0011	0.0011	±0.01	Pass

Voltage Variations

Test Mode		Continuous TX Mode					
Temp. (°C)	Voltage (VAC)	0 minute Frequency Tolerance (%)	2 minutes Frequency Tolerance (%)	5 minutes Frequency Tolerance (%)	10 minutes Frequency Tolerance (%)	Limit (%)	Result (Pass/Fail)
20	V _{Low}	0.0007	0.0007	0.0007	0.0007	±0.01	Pass
	V _{Nom}	0.0004	0.0004	0.0004	0.0004	±0.01	Pass
	V _{High}	0.0007	0.0007	0.0007	0.0007	±0.01	Pass

Note: V_{Low}=V_{Nom}-15 % ; V_{High}=V_{Nom}+15 %

20 dB Bandwidth Measurement

Test Mode	Continuous TX mode	
Frequency (kHz)	20 dB Bandwidth (kHz)	
13.56	7.1	

■ Test Graphs

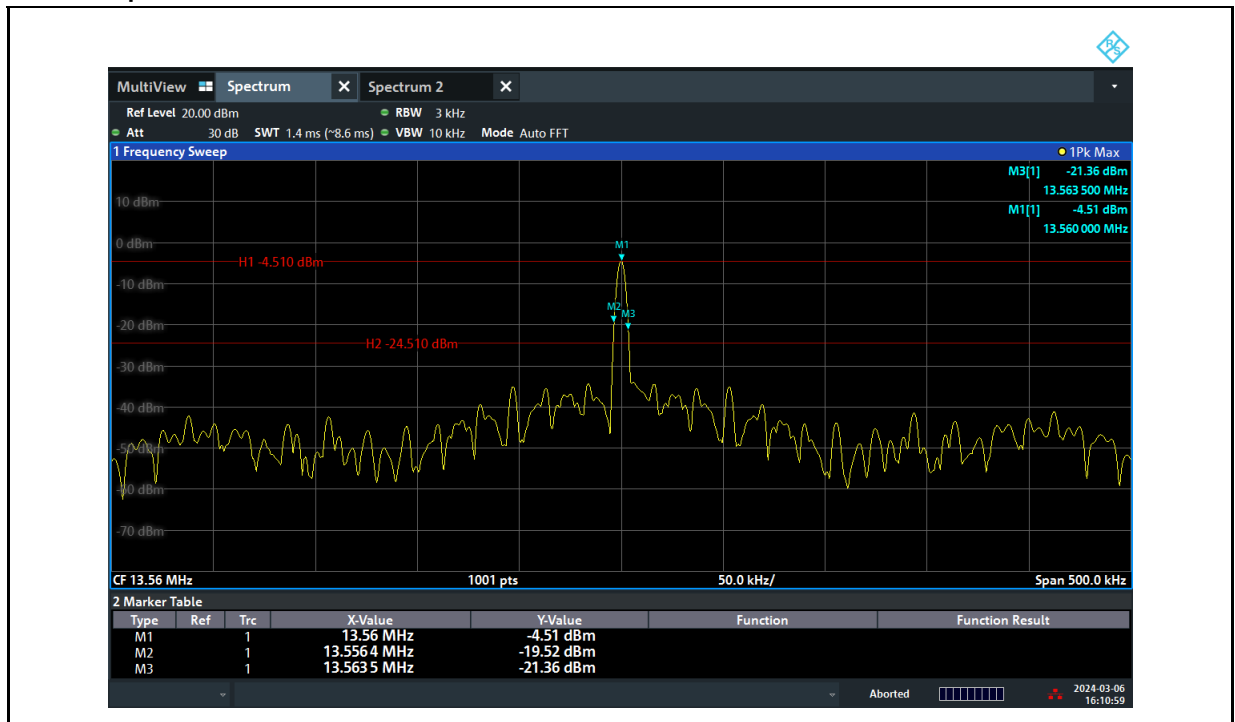

5.3. Radiated Emission Measurement

Fundamental

Standard:	Part 15.225	Test Distance:	1 m
Test item:	Fundamental		
Mode:	Continuous TX Mode		
Ant.Polar.:	Horizontal		

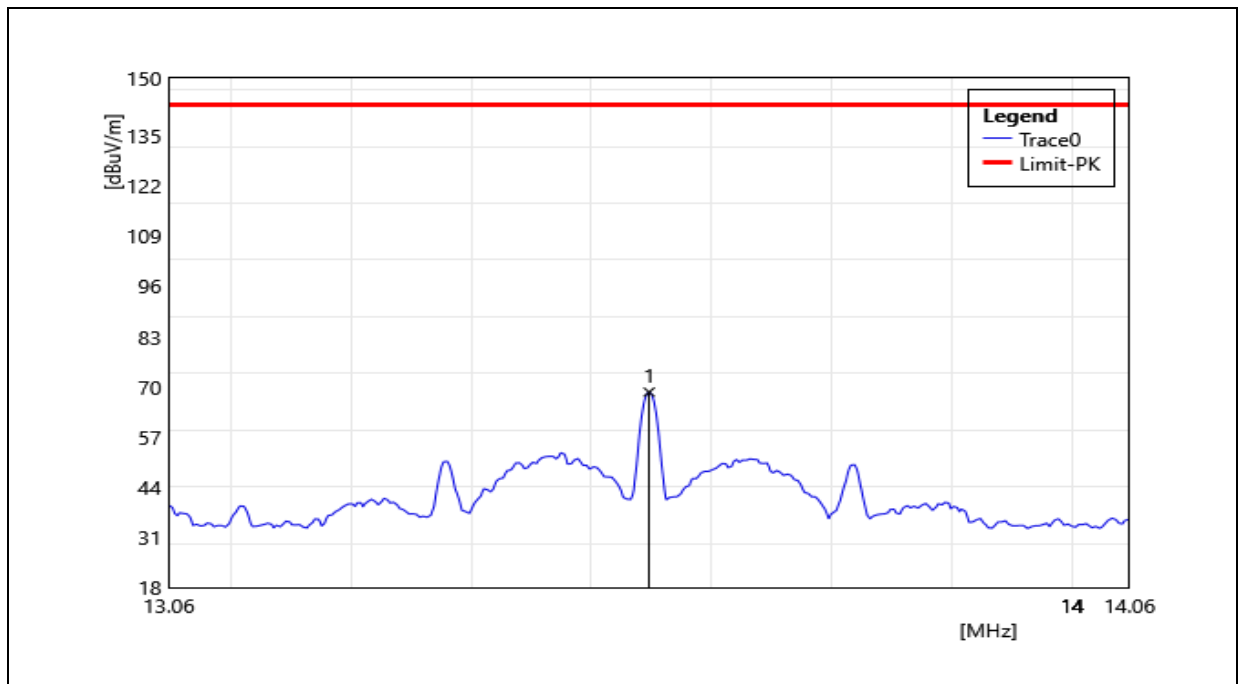

No.	Frequency (MHz)	Reading (dBuV)	Correct Factor (dB/m)	Near-Field Result (dBuV/m)	Derived Value (dBuV/m)	Limit (dBuV/m)	Margin (dB)	Remark
1	13.5600	47.87	20.76	68.63	28.16	84.00	-55.84	PEAK

Note: The level is measured at 1 meter and is converted into result at 30 meter.

The converted formula listed below:

Measure result (1 meter distance): a

Compute result (30 meter distance): A

$d_{near\ field} = \lambda / 2\pi$, $d_{measure} = 1$ meter distance

$A = a - 40 \cdot \log(d_{near\ field} / d_{measure}) - 20 \cdot \log(d_{limit} / d_{near\ field})$

Standard:	Part 15.225	Test Distance:	1 m
Test item:	Fundamental		
Mode:	Continuous TX Mode		
Ant.Polar.:	Vertical		

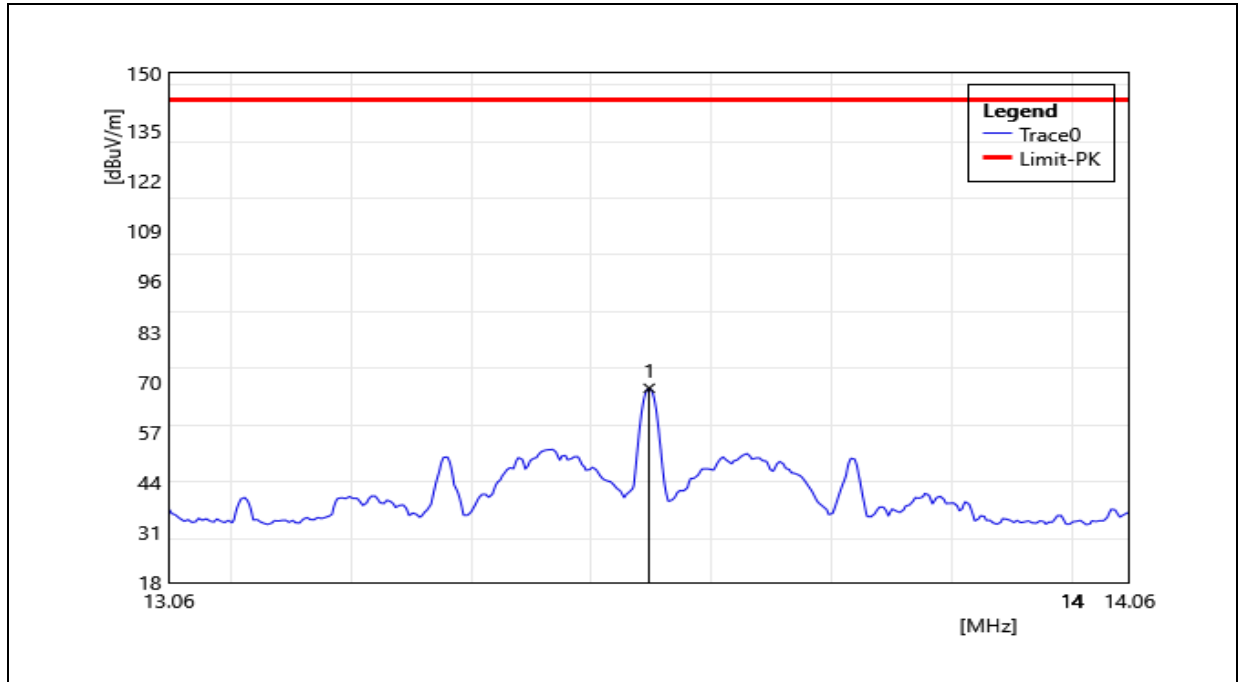

No.	Frequency (MHz)	Reading (dBuV)	Correct Factor (dB/m)	Near-Field Result (dBuV/m)	Derived Value (dBuV/m)	Limit (dBuV/m)	Margin (dB)	Remark
1	13.5600	47.59	20.76	68.35	27.88	84.00	-56.12	PEAK

Note: The level is measured at 1 meter and is converted into result at 30 meter.

Standard:	Part 15.225	Test Distance:	1 m
Test item:	MASK		
Mode:	Continuous TX Mode		
Ant.Polar.:	Horizontal		

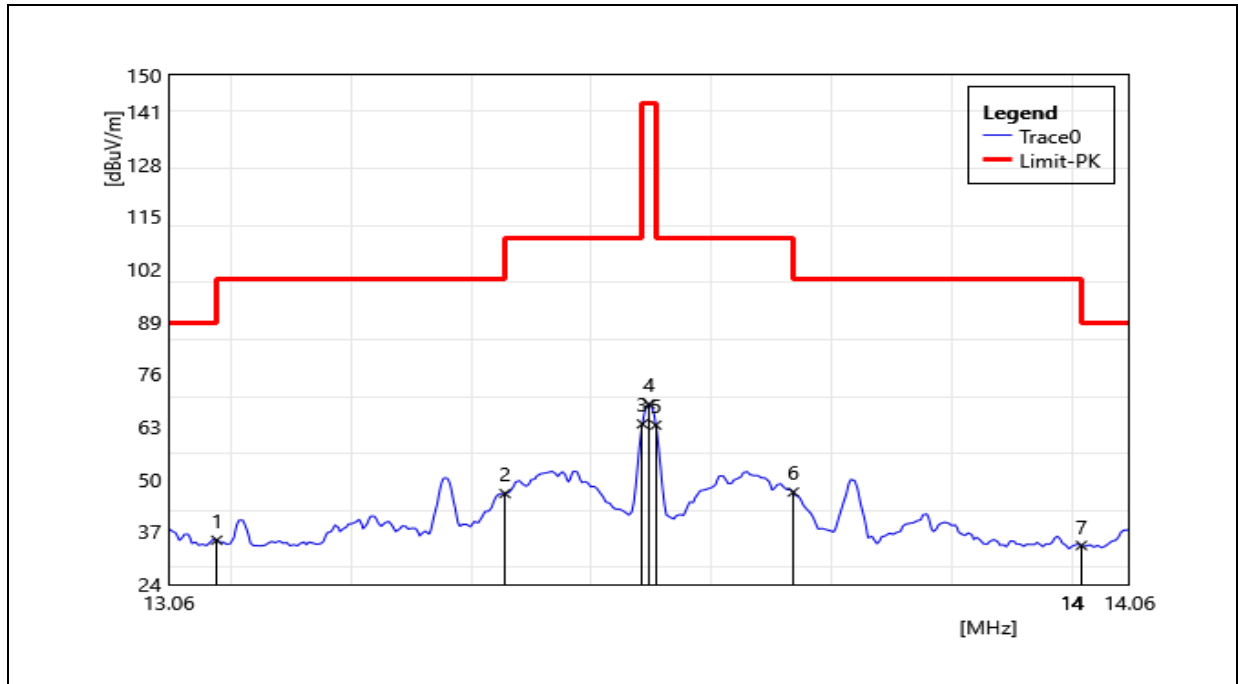

No.	Frequency (MHz)	Reading (dBuV)	Correct Factor (dB/m)	Near-Field Result (dBuV/m)	Derived Value (dBuV/m)	Limit (dBuV/m)	Margin (dB)	Remark
1	13.1100	14.1400	20.8200	34.9600	-26.62	84.00	-110.62	PEAK
2	13.4100	25.7100	20.7800	46.4900	-14.86	84.00	-98.86	PEAK
3	13.5500	42.9800	20.7600	63.7400	2.51	84.00	-81.49	PEAK
4	13.5600	47.8500	20.7600	68.6200	7.38	84.00	-76.62	PEAK
5	13.5700	42.6700	20.7600	63.4300	2.20	84.00	-81.80	PEAK
6	13.7100	26.1200	20.7400	46.8600	-14.25	84.00	-98.25	PEAK
7	14.0100	12.9500	20.6900	33.6400	-27.25	84.00	-111.25	PEAK

Note: The level is measured at 1 meter and is converted into result at 30 meter.

The converted formula listed below:

Measure result (1 meter distance): a

Compute result (30 meter distance): A

$d_{near\ field} = \lambda/2\pi$, $d_{measure} = 1$ meter distance

$A = a - 40 \cdot \log(d_{near\ field} / d_{measure}) - 20 \cdot \log(d_{limit} / d_{near\ field})$

Standard:	Part 15.225	Test Distance:	1 m
Test item:	MASK		
Mode:	Continuous TX Mode		
Ant.Polar.:	Vertical		

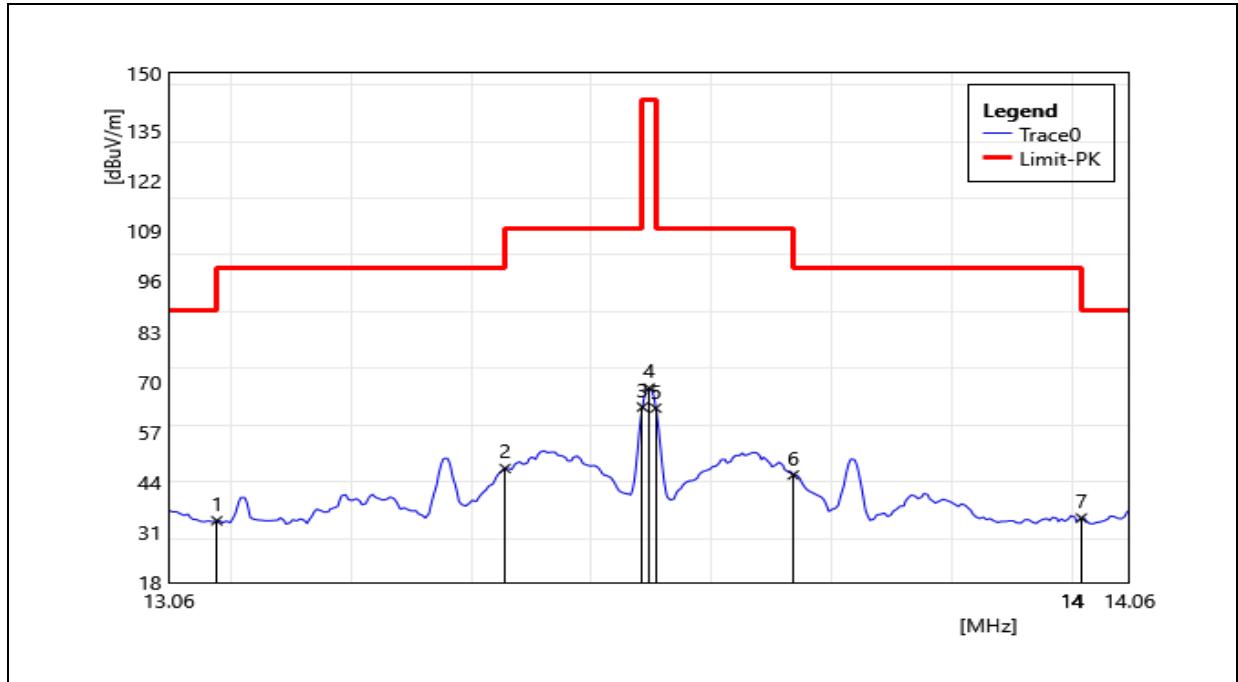

No.	Frequency (MHz)	Reading (dBuV)	Correct Factor (dB/m)	Near-Field Result (dBuV/m)	Derived Value (dBuV/m)	Limit (dBuV/m)	Margin (dB)	Remark
1	13.1100	13.1800	20.8200	34.0000	-27.58	84.00	-111.58	PEAK
2	13.4100	26.7700	20.7800	47.5500	-13.80	84.00	-97.80	PEAK
3	13.5500	42.7100	20.7600	63.4700	2.24	84.00	-81.76	PEAK
4	13.5600	47.6300	20.7600	68.3900	7.16	84.00	-76.84	PEAK
5	13.7000	42.4200	20.7600	63.1800	1.95	84.00	-82.05	PEAK
6	13.7100	25.1000	20.7400	45.8400	-15.27	84.00	-99.27	PEAK
7	14.0100	14.0100	20.6900	34.7000	-26.19	84.00	-110.19	PEAK

Note: The level is measured at 1 meter and is converted into result at 30 meter.

Harmonic

9 kHz ~ 30 MHz:

Standard:	Part 15.225	Test Distance:	300/30 m
Test item:	Harmonic		
Mode:	Continuous TX Mode		
Ant.Polar.:	Horizontal		

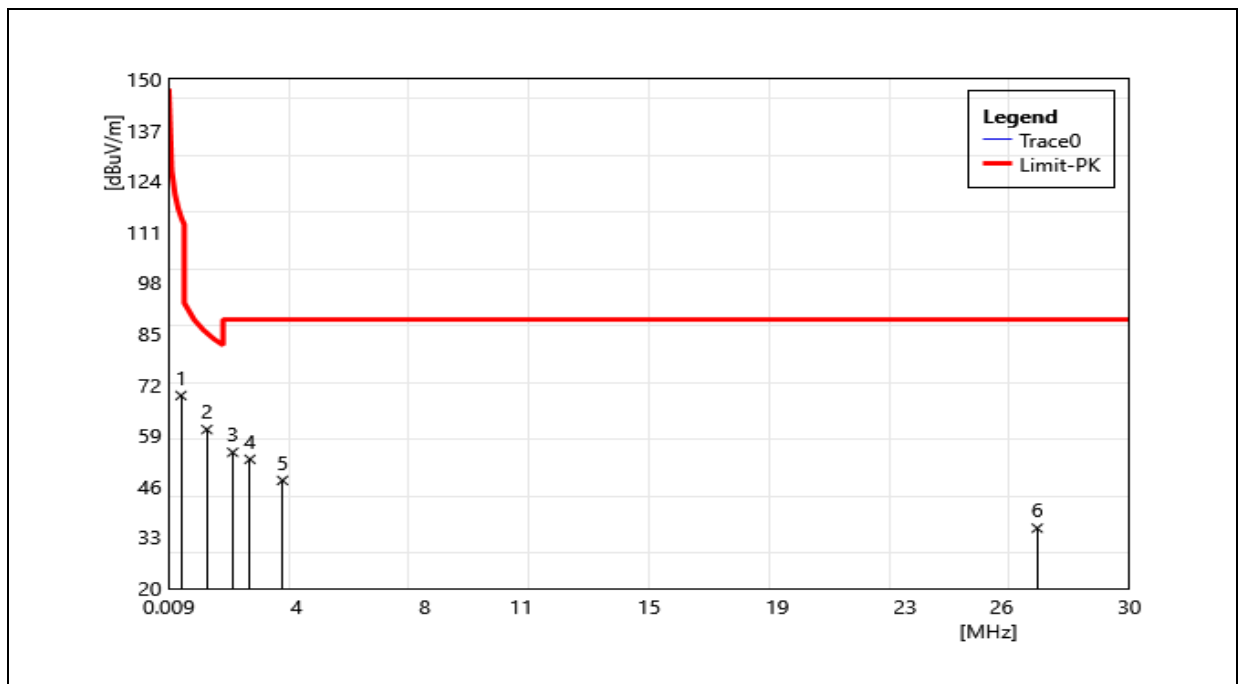

No.	Frequency (MHz)	Reading (dBuV)	Correct Factor (dB/m)	Near-Field Result (dBuV/m)	Derived Value (dBuV/m)	Limit (dBuV/m)	Margin (dB)	Remark
1	0.39	49.68	19.58	69.26	-22.04	15.78	-37.82	PEAK
2	1.2	40.54	20.03	60.57	-0.97	26.02	-26.99	PEAK
3	2	34.95	19.81	54.76	-2.34	29.54	-31.88	PEAK
4	2.54	33.18	19.78	52.96	-2.07	29.54	-31.61	PEAK
5	3.56	27.89	19.68	47.57	-4.52	29.54	-34.06	PEAK
6	27.12	14.49	20.91	35.40	0.95	29.54	-28.60	PEAK

Note: The level is measured at 1 meter and is converted into result at 300 or 30 meter.

Standard:	Part 15.225	Test Distance:	300/30 m
Test item:	Harmonic		
Mode:	Continuous TX Mode		
Ant.Polar.:	Vertical		

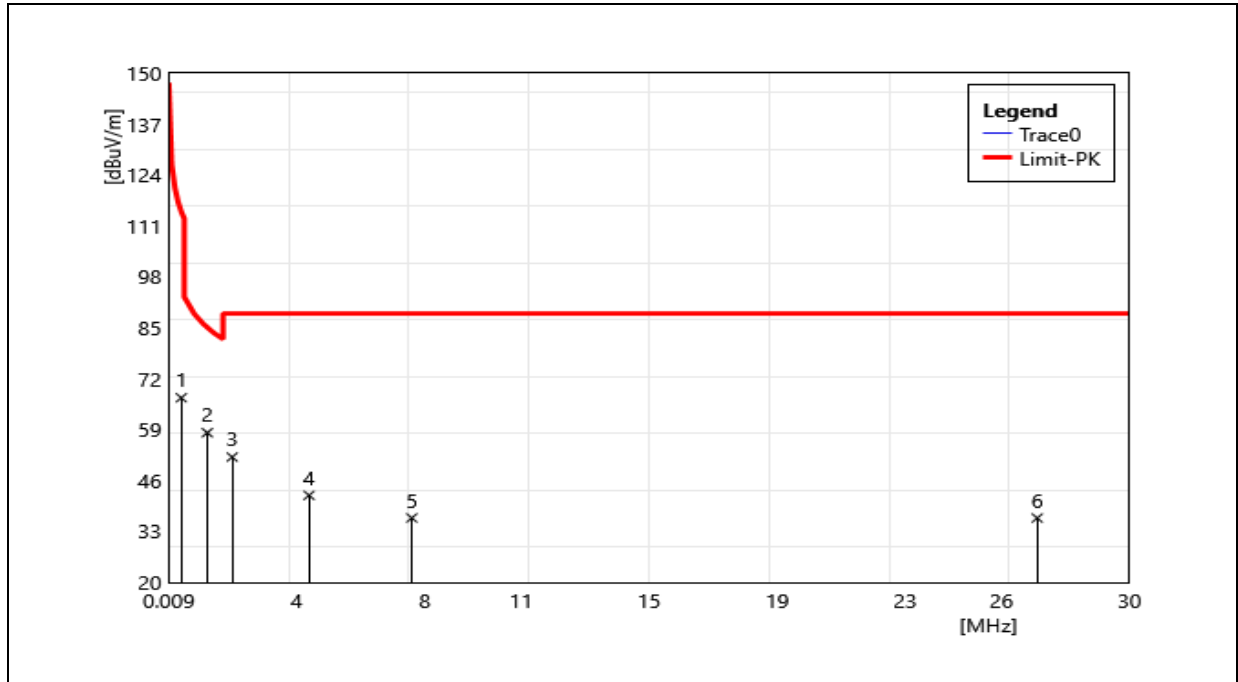

No.	Frequency (MHz)	Reading (dBuV)	Correct Factor (dB/m)	Near-Field Result (dBuV/m)	Derived Value (dBuV/m)	Limit (dBuV/m)	Margin (dB)	Remark
1	0.4	47.54	19.61	67.15	-23.93	15.56	-39.49	PEAK
2	1.21	38.20	20.03	58.23	-3.24	25.95	-29.18	PEAK
3	1.99	32.20	19.82	52.02	-5.12	29.54	-34.67	PEAK
4	4.39	22.72	19.52	42.24	-8.04	29.54	-37.58	PEAK
5	7.6	15.84	20.63	36.47	-9.03	29.54	-38.57	PEAK
6	27.12	15.54	20.91	36.45	2.00	29.54	-27.55	PEAK

Note: The level is measured at 1 meter and is converted into result at 300 or 30 meter.

30 MHz ~ 1 GHz:

Standard:	Part 15.225	Test Distance:	3 m
Test item:	Harmonic		
Mode:	Continuous TX Mode		
Ant.Polar.:	Horizontal		

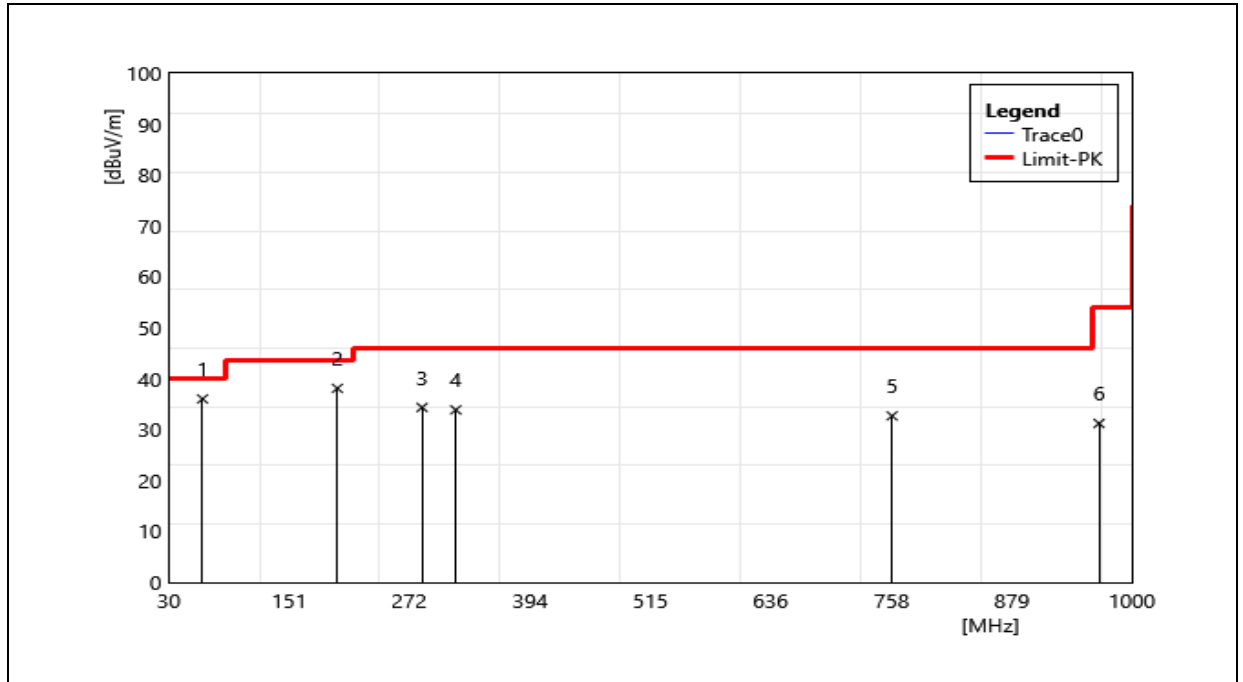

No.	Frequency (MHz)	Reading (dBuV)	Correct Factor (dB/m)	Result (dBuV/m)	Limit (dBuV/m)	Margin (dB)	Remark
1	63.95	49.24	-13.19	36.05	40.00	-3.95	QP
2	199.75	53.32	-15.20	38.12	43.50	-5.38	QP
3	285.11	46.44	-12.07	34.37	46.00	-11.63	QP
4	319.06	45.12	-11.22	33.90	46.00	-12.10	QP
5	758.47	35.02	-2.31	32.71	46.00	-13.29	QP
6	967.02	31.21	0.02	31.23	54.00	-22.77	QP

Standard:	Part 15.225	Test Distance:	3 m
Test item:	Harmonic		
Mode:	Continuous TX Mode		
Ant.Polar.:	Vertical		

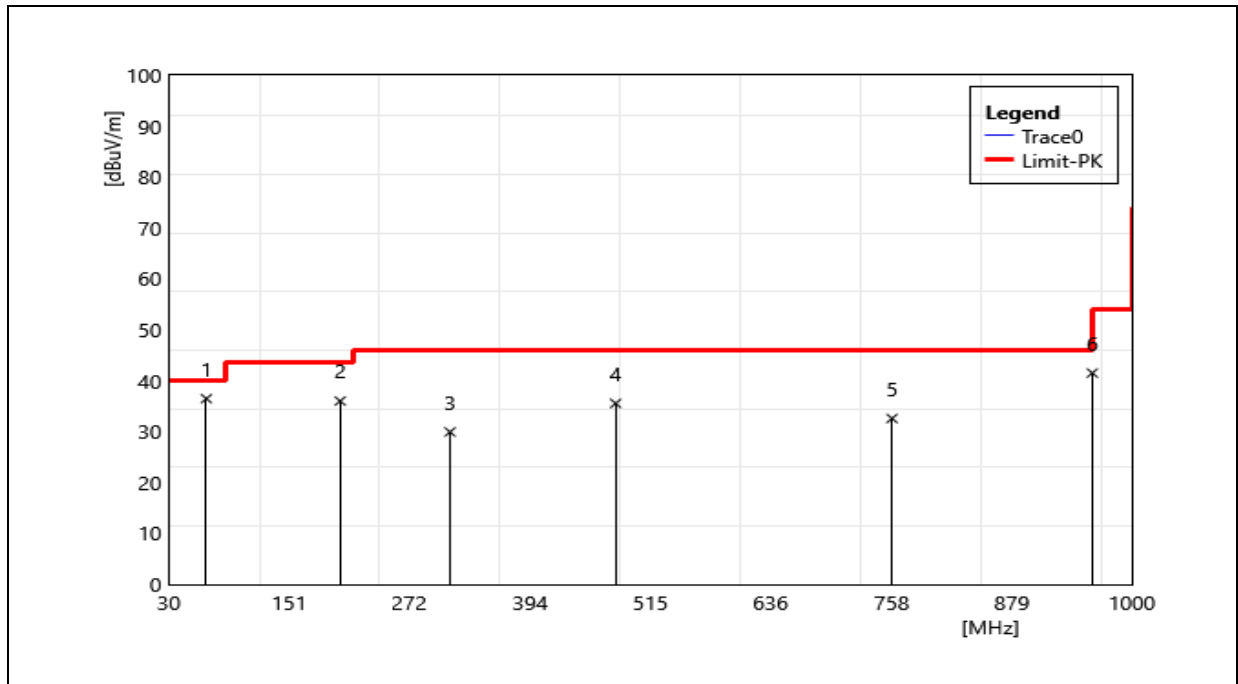

No.	Frequency (MHz)	Reading (dBuV)	Correct Factor (dB/m)	Result (dBuV/m)	Limit (dBuV/m)	Margin (dB)	Remark
1	67.83	50.38	-13.88	36.50	40.00	-3.50	QP
2	202.66	51.24	-15.22	36.03	43.50	-7.48	QP
3	313.24	41.38	-11.43	29.96	46.00	-16.05	QP
4	480.08	42.94	-7.36	35.58	46.00	-10.43	QP
5	758.47	34.90	-2.31	32.59	46.00	-13.41	QP
6	960.23	41.32	0.20	41.52	54.00	-12.48	QP

---END---