



FCC RF Test Report

Product Name: HSDPA Module

Model Number: MU509-c

Report No: SYBHZ(R)E005112010EB-2

FCC ID: QISMU509C

IC ID: 6369A-MU509C

Reliability Laboratory of Huawei Technologies Co., Ltd.

Huawei Base, Bantian, Longgang District, Shenzhen 518129, P.R. China

Tel: +86 755 28780808 Fax: +86 755 89652518



Notice

1. The laboratory has obtained the accreditation of China National Accreditation Service for Conformity Assessment (CNAS), and accreditation number: L0310.
2. The laboratory has been listed on the US Federal Communications Commission list of test facilities recognized to perform electromagnetic emissions measurements. The site recognition number is 97456.
3. The laboratory has been listed by industry Canada to perform electromagnetic emission measurement. The site recognition number is 6369A-1.
4. The test report is invalid if not marked with "exclusive stamp for the test report".
5. The test report is invalid if not marked with the stamps or the signatures of the persons responsible for performing, revising and approving the test report.
6. The test report is invalid if there is any evidence of erasure and/or falsification.
7. If there is any dissidence for the test report, please file objection to the test centre within 15 days from the date of receiving the test report.
8. Normally, the test report is only responsible for the samples that have undergone the test.
9. Context of the test report cannot be used partially or in full for publicity and/or promotional purposes without previous written approval of the laboratory.



Notice 2

Modification Information:

Modification Information

| | | |
|--------------------------|---|------------------------|
| Modification Information | 1 | |
| | 2 | |
| | 3 | <i>Not Applicable!</i> |
| | 4 | |
| | 5 | |
| | 6 | |
| | 7 | |



| | |
|-------------------------|---------------------------------------|
| REGULATION | FCC CFR47 Part 2: Subpart J; |
| | FCC CFR47 Part 22 : Subpart H; |
| | RSS-Gen Issue 2 June 2007 |
| | RSS-132 Issue 2 September 2005 |
| | |
| | |
| | |
| START OF TEST | Nov.15, 2010 |
| END OF TEST | Nov.18, 2010 |
| | |
| Final Judgement: | Pass |

Approved By

Nov.18, 2010
Date

Liuchunlin
Name

Liuchunlin

Signature

Reviewed By

Nov.18, 2010
Date

Chenxiaohong
Name

Chen Xiaohong

Signature

Operator

Nov.18, 2010
Date

Zhangting
Name

Zhang Ting

Signature



Contents

| | | |
|----------|----------------------------------------------------|-----------|
| 1 | <u>Summary</u> | 6 |
| 2 | <u>Product Description</u> | 7 |
| 2.1 | PRODUCTION INFORMATION | 7 |
| 2.2 | MODIFICATION INFORMATION..... | 7 |
| 3 | <u>Test Site Description</u> | 8 |
| 3.1 | TESTING PERIOD | 8 |
| 3.2 | GENERAL SET UP DESCRIPTION | 8 |
| 4 | <u>Product Description</u> | 9 |
| 4.1 | TECHNICAL CHARACTERISTICS | 9 |
| 4.2 | EUT IDENTIFICATION LIST | 11 |
| 5 | <u>Main Test Instruments</u> | 12 |
| 6 | <u>Transmitter Measurements</u> | 13 |
| 6.1 | EFFECTIVE RADIATED POWER OF TRANSMITTER (ERP)..... | 13 |
| 6.2 | CONDUCTED POWER OF TRANSMITTER..... | 17 |
| 6.3 | MODULATION CHARACTERISTICS | 20 |
| 6.4 | OCCUPIED BANDWIDTH..... | 22 |
| 6.5 | BAND EDGES COMPLIANCE | 25 |
| 6.6 | SPURIOUS EMISSION AT ANTENNA TERMINAL | 27 |
| 6.7 | FREQUENCY STABILITY | 30 |
| 7 | <u>System Measurement Uncertainty</u> | 34 |
| 8 | <u>Appendices</u> | 35 |



1 Summary

The table below summarizes the measurements and results for the HUAWEI MU509-c Module. Detailed results and descriptions are shown in the following pages.

Table 1 Summary of results

| FCC Measurement Specification | FCC Limits Part(s) | Description | Result |
|--------------------------------------|---------------------------|-----------------------------------------|---------------|
| 2.1046 | 22.913 | Effective Radiated Power of Transmitter | PASS |
| 2.1046 | 22.913 | Conducted Power of Transmitter | PASS |
| 2.1047 | | Modulation Characteristics | PASS |
| 2.1049 | | Occupied Bandwidth | PASS |
| 2.1051 | 22.917 | Band Edges compliance | PASS |
| 2.1051 | 22.917 | Spurious Emission at Antenna Terminal | PASS |
| 2.1055 | 22.355 | Frequency Stability | PASS |
| 2.1053 | 22.917 | Radiated Spurious Emissions | PASS |

| Section in CFR 47 | Section in RSS-132 | Description | Result |
|--------------------------|---------------------------|-----------------------------------------|---------------|
| 22.913 | 4.4 | Effective Radiated Power of Transmitter | PASS |
| 2.1046 | 4.4 | Conducted RF output power | PASS |
| 2.1049 | 4.5 | Occupied Bandwidth | PASS |
| 22.917 | 4.5 | Band Edges compliance | PASS |
| 2.1051, 22.917 | 4.5 | Spurious Emission at Antenna Terminal | PASS |
| 2.1053, 22.917 | 4.5 | Radiated Spurious Emission | PASS |
| 2.1055 | 4.3 | Frequency Stability | PASS |

Note: The Radiated Spurious Emissions' test results are shown in the EMC report.



2 Product Description

2.1 Production Information

2.1.1 General Description

MU509-c Module is subscriber equipment in the GSM/UMTS system. The frequency band of this report is 850M. The MU509-c implements such functions as RF signal receiving / Transmitting, HSDPA/WCDMA/EDGE/GPRS/GSM protocol processing and data service etc. Externally it provides LGA interface. It has not an internal antenna. MU509-c uses Qualcomm QSC6270 chipset and Zero-IF technologies.

2.1.2 Support function and Service

The HUAWEI MU509-c Module support the function and service as follows:

Table 2 Service and Test mode List

| Service Name | Characteristic | Corresponding Test Mode | Note |
|--------------|------------------|-------------------------|----------|
| Data | Modulation: GMSK | TM1 | GPRS/GSM |
| Data | Modulation: 8PSK | TM2 | EDGE |
| Data | Modulation: QPSK | TM3 | WCDMA |
| Data | Modulation: QPSK | TM4 | HSDPA |

Note: * The specified GPRS test conditions & settings are defined in 3GPP TS51.010 V5.4.0 and the EDGE test conditions & settings are defined in 3GPP TS51.010 V5.4.0. The WCDMA test condition & settings are defined in 3GPP TS 34.121 V8.7.0:2009.

2.2 Modification Information

For original equipment, following table is not application.

Table 3 Modification Information

| Model Number | Board/Module | Original Version | New Version | Modify Information |
|----------------|--------------|------------------|-------------|--------------------|
| Not applicable | | | | |
| Not applicable | | | | |
| Not applicable | | | | |



3 Test Site Description

The test site of:

***Huawei Technologies Co. Ltd.
P.O. Box 518129
Huawei base, bantian,
Longgang District, Shenzhen, China***

3.1 Testing Period

The test have been performed during the period of

Nov.15, 2010 – Nov.18, 2010

3.2 General Set up Description

HUAWEI MU509-c Module can support GSM/GPRS/EDGE/WCDMA/HSDPA mode and 850M Band in this report. During this measurement, the HUAWEI MU509-c Module just works in GSM/GPRS/EDGE/WCDMA/HSDPA mode and 850M Band.

TM1: GSM/GPRS Mode with GMSK Modulation

TM2: EDGE Mode with 8PSK Modulation

TM3: WCDMA Mode with QPSK Modulation

TM4: HSDPA Mode with QPSK Modulation



4 Product Description

4.1 Technical Characteristics

4.1.1 Frequency Range

Table 4 Frequency Range

| | |
|----------------|----------------|
| Uplink band: | 824 to 849 MHz |
| Downlink band: | 869 to 894 MHz |

4.1.2 Channel Spacing / Separation

Table 5 Channel Spacing / Separation

| | EDGE/GPRS/GSM | WCDMA/HSDPA |
|------------------|---------------|-------------|
| Channel Raster | 200k Hz | 200k Hz |
| Channel spacing: | 200k Hz | 5MHz |

4.1.3 Type of Emission

Table 6 Type of Emission

| | EDGE/GPRS/GSM | WCDMA/HSDPA |
|-----------------------|-------------------|-------------|
| Emission Designation: | 300KG7W / 300KGXW | 5M00F9W |

According to CFR 47 (FCC) part 2, subpart C, section 2.201 and 2.202

4.1.4 Environmental Requirements

Table 7 Environmental Requirements

| | |
|----------------------|----------|
| Minimum temperature: | - 20 °C |
| Maximum temperature: | + 70 °C |
| Relative Humidity: | 5%-95%RH |

4.1.5 Power Source

Table 8 Power Source

| | |
|---------------------|-----------------------------------|
| DC voltage nominal: | ≡ 3.8V; Supplied by LGA interface |
| DC voltage range | ≡ 3.3-4.2V |
| DC current maximal: | 1A |

4.1.6 Tune-up Procedure

According to CFR (FCC) part 2, subpart 2, section 2.1033(c) (9).

Please reference the document Tune-up Procedure in TCF.

4.1.7 Applied DC Voltages and Currents

According to CFR (FCC) part 2, subpart 2, section 2.1033(c) (8).

The voltage and current in the final RF stage is:

Table 9 Applied RF Module DC Voltages and Currents

| | |
|----------|-----------------------------------------------------------------------|
| Voltage: | ≡ 2.85V (for the RF IC) |
| Current: | 150mA According to CFR (FCC) part 2, subpart 2, section 2.1033(c) (8) |
| Voltage: | ≡ 3.6V (for the PA module) |
| Current: | 350mA According to CFR (FCC) part 2, subpart 2, section 2.1033(c) (8) |



4.2 EUT Identification List

4.2.1 Board Information

Table 10 Board Information

| | | |
|------------------|------------------|---------|
| HSDPA Module | | |
| MU509-c | | |
| Board and Module | | |
| Model name | Serial Number | Remarks |
| MU509-c | 4CA2A110A1900056 | QSC6270 |

4.2.2 Adapter Technical Data

No Applicable.

4.2.3 Battery Technical Data

No Applicable.

4.2.4 FCC Identification

FCC Identification: QISMU509C
IC Identification: 6369A-MU509C

5 Main Test Instruments

Table 11 Main Test Equipments

| Equipment Description | Manufacturer | Model | Serial Number | Calibrated until (MM.DD.YYYY) |
|--------------------------------------|--------------|-------------------------|--------------------|-------------------------------|
| EMI Test receiver | R&S | ESIB 26 | 100318 | 05.04.2011 |
| Broadband Antenna | Schaffner | CBL 6112B | 2941 | 04.17, 2011 |
| Horn Antenna | R & S | HF906 | 359287/006 | 06.15.2011 |
| Tunable Dipole | Schwarzbeck | D69250-UHAP/D69250-VHAP | 979/917 | 11.20.2010 |
| Signal Generator | R&S | SMR 40 | 100325 | 05.12, 2011 |
| Vector Signal Generator | R&S | SMU200A | 3605064030 | 05.20.2011 |
| Power Supply | Agilent | 66311B | MY43006371 | 03.26.2011 |
| Climate Chamber | WEISS | WK11-600/70 | 5922602844001 0 | 09.26.2011 |
| Universal Radio Communication Tester | R&S | CMU200 | 113164 | 05.21.2011 |
| Spectrum Analyzer | R&S | FSU26 | 200002 | 03.07.2011 |

6 Transmitter Measurements

6.1 Effective Radiated Power of Transmitter (ERP)

6.1.1 Test Conditions

Table 12 Test Conditions

| | |
|----------------------|------------------------------------------------|
| Preconditioning: | 0.5 hour |
| Measured at: | enclosure |
| Ambient temperature: | 25°C |
| Relative humidity: | 55% |
| Test Configurations: | TM1/TM2/TM3/TM4 at Channel Bottom, Middle, Top |

6.1.2 Test Specifications and Limits

6.1.2.1 Specification

CFR 47 (FCC) part 2.1046 and part 22 subpart H

6.1.2.2 Supporting Standards

Table 13 Supporting Standards:

| | |
|-----------------------------|--------------------------------------------------------------------------------------------------------------------------------------------|
| ANSI/TIA-603-C:2004 | Land Mobile FM or PM Communications Equipment Measurement and Performance Standards |
| 3GPP TS51.010 V5.4.0.0:2005 | Digital cellular telecommunications system Mobile Station (MS) conformance specification; |
| 3GPP TS 34.121 V8.7.0:2009 | Technical Specification Group Radio Access Network; User Equipment (UE) conformance specification; Radio transmission and reception (FDD); |

6.1.2.3 Limits

Compliance with part 22.913, mobile/portable stations are limited to 7 watts ERP peak power.
 W (dBm) = $10 \cdot \log(W_{in\ mW})$.

Table 14 Limits

| | |
|------------------------------|------------|
| Maximum Output Power (Watts) | < 7 Watts |
| Maximum Output Power (dBm) | < 38.5 dBm |

6.1.3 Test Method and Setup

- For transmitters other than single sideband, independent sideband and controlled carrier radiotelephone, ERP shall be measured when the transmitter is adjusted in accordance with the tune-up procedure to give the values of current and voltage on the circuit elements specified in 2.1033(c)(8). Connect the HUAWEI MU509-c Module to the wireless communication tester CMU200 via the air interface. The band is set as 850M.
- Test the Radiated maximum output power by the CMU200 received from test antenna.

- (c) Use substitution method to verify the maximum output power. The EUT is substituted by a dipole antenna. The dipole is connected to a signal generator. And then adjust the output level of the signal generator to get the same received power recorded in step (b) on CMU200, and record the power level of Signal Generator. Of course, the cable loss at the test frequency should be compensated.

Test setup

Step 1: Pre-test

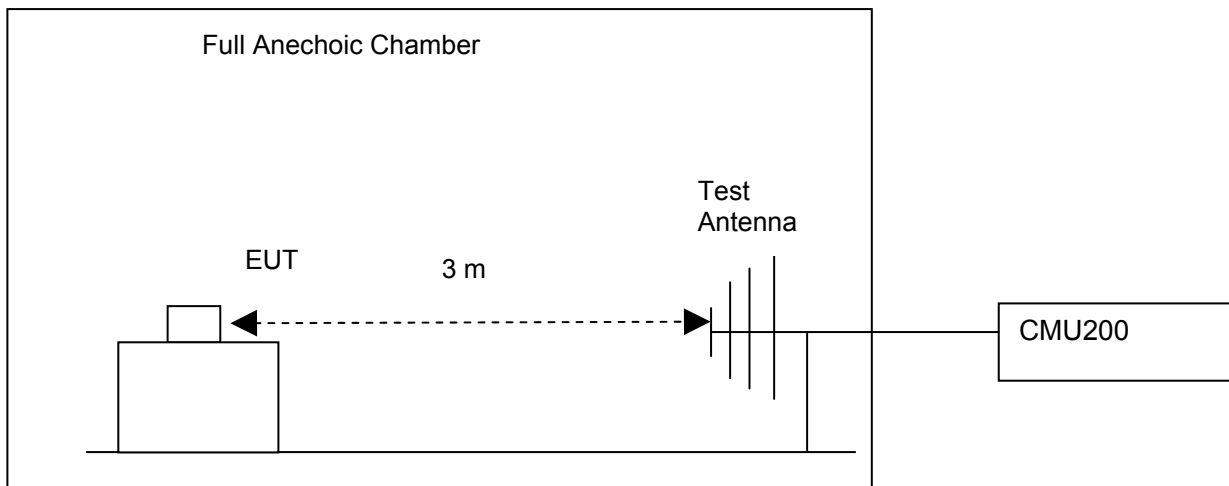

Step 2: Substitution method to verify the maximum ERP

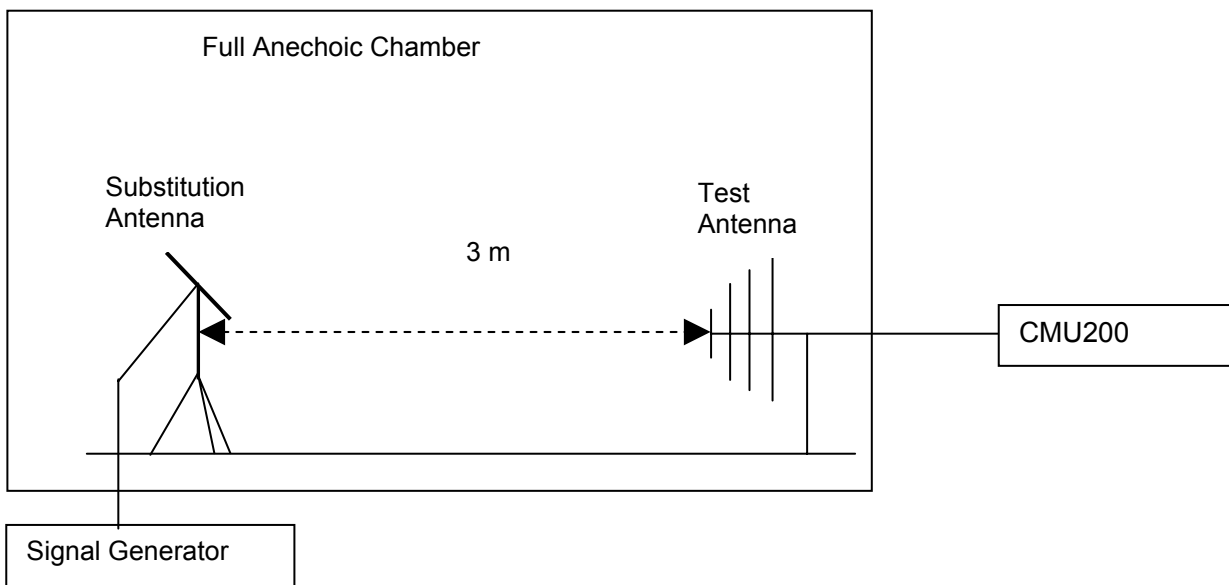

Figure 1. Test Set-up

NOTE: Effective radiated power (ERP) refers to the radiation power output of the EUT, assuming all emissions are radiated from half-wave dipole antennas.

ERP was measured using 1 host.

BenQ Joy book S72

6.1.4 Measurement Results

6.1.4.1 Pre-test Results

Table 15 Measurement Results

| TEST CONDITIONS | RF Output Power (ERP) | | | | | |
|---------------------------|---------------------------|-------|---------------------------|-------|---------------------------|-------|
| | Channel128(B) 824.2MHz | | Channel192(M) 837.0MHz | | Channel251(T) 848.8MHz | |
| | dBm | | dBm | | dBm | |
| Tnom (25 °C)/ Vnom (3.8V) | Measured | Limit | Measured | Limit | Measured | Limit |
| TM1 | 33.90 | 38.5 | 33.94 | 38.5 | 33.68 | 38.5 |
| TM2 | 28.52 | 38.5 | 28.49 | 38.5 | 28.29 | 38.5 |

| TEST CONDITIONS | RF Output Power (ERP) | | | | | |
|---------------------------|----------------------------|-------|----------------------------|-------|----------------------------|-------|
| | Channel4132(B) 826.4MHz | | Channel4182(M) 836.4MHz | | Channel4233(T) 846.6MHz | |
| | dBm | | dBm | | dBm | |
| Tnom (25 °C)/ Vnom (3.8V) | Measured | Limit | Measured | Limit | Measured | Limit |
| TM3 | 23.49 | 38.5 | 24.05 | 38.5 | 23.85 | 38.5 |

6.1.4.2 Substitution Results

Table 16 Substitution Results

| Test Mode | Freq. [MHz] | Meas. Level [dBm] | Substitution Antenna Type | SGP [dBm] | Substitution Gain [dBd] | Cable Loss [dB] | Substitution Level (ERP) [dBm] | FCC limit [dBm] | Result |
|-----------|-------------|-------------------|---------------------------|-----------|-------------------------|-----------------|--------------------------------|-----------------|--------|
| TM1 | 824.2 | 33.90 | Dipole Ant. | 37.06 | -2.75 | 0.6 | 33.71 | 38.5 | Pass |
| TM1 | 837.0 | 33.94 | Dipole Ant. | 37.26 | -2.87 | 0.6 | 33.79 | 38.5 | Pass |
| TM1 | 848.8 | 33.68 | Dipole Ant. | 36.97 | -2.85 | 0.6 | 33.52 | 38.5 | Pass |
| TM2 | 824.2 | 28.52 | Dipole Ant. | 31.78 | -2.75 | 0.6 | 28.43 | 38.5 | Pass |
| TM2 | 837.0 | 28.49 | Dipole Ant. | 31.87 | -2.87 | 0.6 | 28.40 | 38.5 | Pass |
| TM2 | 848.8 | 28.29 | Dipole Ant. | 31.53 | -2.85 | 0.6 | 28.08 | 38.5 | Pass |
| TM3 | 826.4 | 23.49 | Dipole Ant. | 26.82 | -2.75 | 0.6 | 23.47 | 38.5 | Pass |
| TM3 | 836.4 | 24.05 | Dipole Ant. | 27.31 | -2.87 | 0.6 | 23.84 | 38.5 | Pass |
| TM3 | 846.6 | 23.85 | Dipole Ant. | 27.08 | -2.85 | 0.6 | 23.63 | 38.5 | Pass |



Note: a, For get the ERP (Efficient Radiated Power) in substitution method, the following formula should take to calculate it,

$$\text{ERP [dBm]} = \text{SGP [dBm]} - \text{Cable Loss [dB]} + \text{Gain [dBd]}$$

NOTE: SGP- Signal Generator Level

b, RBW=10kHz, VBW=300kHz, and integrated by the instrument to 200kHz for TM1 and TM2 and 5M for TM3 and TM4.

6.1.5 Conclusion

The equipment **PASSED** the requirement of this clause.



6.2 Conducted Power of Transmitter

6.2.1 Test Conditions

Table 17 Test Conditions

| | |
|----------------------|------------------------------------------------|
| Preconditioning: | 0.5 hour |
| Measured at: | Antenna connector |
| Ambient temperature: | 25 °C |
| Relative humidity: | 52 % |
| Test Configurations: | TM1/TM2/TM3/TM4 at Channel Bottom, Middle, Top |

6.2.2 Test Specifications and Limits

6.2.2.1 Specification

CFR 47 (FCC) part 2.1047 and part 22 subpart H

6.2.2.2 Supporting Standards

Table 18 Supporting Standards:

| | |
|-----------------------------|--------------------------------------------------------------------------------------------------------------------------------------------|
| ANSI/TIA-603-C: 2004 | Land Mobile FM or PM Communications Equipment Measurement and Performance Standards |
| 3GPP TS51.010 V5.4.0.0:2005 | Digital cellular telecommunications system Mobile Station (MS) conformance specification; |
| 3GPP TS 34.121 V8.7.0:2009 | Technical Specification Group Radio Access Network; User Equipment (UE) conformance specification; Radio transmission and reception (FDD); |

6.2.2.3 Limits

Compliance with part 22.913, in no any case may the peak power of a mobile station transmitter exceed 7 W. The calculated longitude ERP by following formula:

$$ERP(\text{dBm}) = 10 * \log(ERP_{\text{in watts}}).$$

And for conducted power, we can use Antenna Gain to calculate the limit. So the conducted power:

$$P_{\text{cod}}(\text{dBm}) = ERP(\text{dBm}) - \text{Gain}(\text{dBd}).$$

and $\text{Gain}(\text{dBd}) = \text{Gain}(\text{dBi}) - 2.15\text{dB}$

Table 19 Limits

| | |
|------------------------------|--------------------|
| Maximum Output Power (Watts) | < 7 Watts(38.5dBm) |
| Antenna Gain(dBi): | 4.28 |

| | |
|--------------------------------------|---------|
| Antenna Gain(dBd): | 2.13 |
| Maximum Conducted Output Power (dBm) | < 36.37 |

For HSDPA test mode, there are 4 sub-tests for different configuration.

HSDPA conducted max power pre-scan

| Sub-test | c | d | d (SF) | c/d | HS (Note1, Note 2) | CM (dB) (Note 3) | MPR (dB) (Note 3) |
|----------|-------|-------|--------|-------|--------------------|------------------|-------------------|
| 1 | 2/15 | 15/15 | 64 | 2/15 | 4/15 | 0 | 0 |
| 2 | 12/15 | 15/15 | 64 | 12/15 | 24/15 | 1 | 0 |
| 3 | 15/15 | 8/15 | 64 | 15/8 | 30/15 | 1.5 | 0.5 |
| 4 | 15/15 | 4/15 | 64 | 15/4 | 30/15 | 1.5 | 0.5 |

6.2.3 Test Method and Setup

(a)For transmitters other than single sideband, independent sideband and controlled carrier radiotelephone, Conducted maximum power shall be measured when the transmitter is adjusted in accordance with the tune-up procedure to give the values of current and voltage on the circuit elements specified in 2.1033(c)(8). Connect the HUAWEI MU509-c Module to the wireless communication tester CMU200 via the antenna connector. The band class is set as US Cellular.

(b)Test the Conducted maximum output power by the CMU200.

Test setup

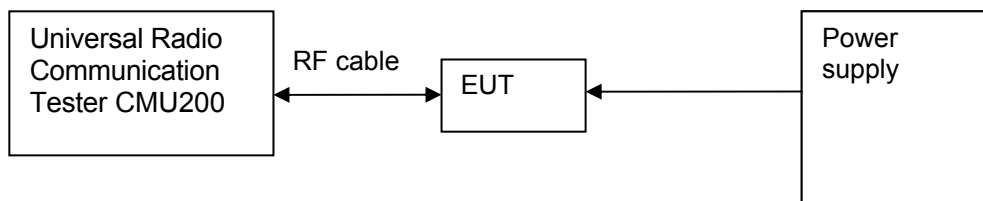

Figure 2. Test Set-up

6.2.4 Measurement Results

Table 20 Measurement Results

| TEST CONDITIONS | RF Output Power (Conducted) | | |
|-----------------|-----------------------------|---------------|---------------|
| | Channel128(B) | Channel192(M) | Channel251(T) |
| | | | |



| | 824.2MHz | | 837.0MHz | | 848.8MHz | | |
|---------------------------|----------------------------|-------|----------------------------|-------|----------------------------|-------|-------|
| | dBm | | dBm | | dBm | | |
| Tnom (25 °C)/ Vnom (3.8V) | Measured | Limit | Measured | Limit | Measured | Limit | |
| TM1 | 31.77 | 36.37 | 31.81 | 36.37 | 31.55 | 36.37 | |
| TM2 | 26.39 | 36.37 | 26.36 | 36.37 | 26.16 | 36.37 | |
| TEST CONDITIONS | | | | | | | |
| | Channel4132(B) 826.4MHz | | Channel4182(M) 836.4MHz | | Channel4233(T) 846.6MHz | | |
| | dBm | | dBm | | dBm | | |
| Tnom (25 °C)/ Vnom (3.8V) | Measured | Limit | Measured | Limit | Measured | Limit | |
| TM3 | 21.36 | 36.37 | 21.92 | 36.37 | 21.72 | 36.37 | |
| TM4 | Case1 | 20.88 | 36.37 | 21.41 | 36.37 | 21.20 | 36.37 |
| | Case2 | 20.69 | 36.37 | 21.20 | 36.37 | 21.01 | 36.37 |
| | Case3 | 20.04 | 36.37 | 20.63 | 36.37 | 20.44 | 36.37 |
| | Case4 | 19.06 | 36.37 | 19.61 | 36.37 | 19.43 | 36.37 |

6.2.5 Conclusion

The equipment **PASSED** the requirement of this clause.

6.3 Modulation Characteristics

6.3.1 Test Conditions

Table 21 Test Conditions

| | |
|----------------------|---------------------------------|
| Preconditioning: | 0.5 hour |
| Measured at: | Antenna connector |
| Ambient temperature: | 25 °C |
| Relative humidity: | 52 % |
| Test Configurations: | TM1/TM2/TM3 at frequency Middle |

6.3.2 Test Specifications and Limits

6.3.2.1 Specification

CFR 47 (FCC) part 2.1047 and part 22 subpart H

6.3.2.2 Supporting Standards

Table 22 Supporting Standards:

| | |
|-----------------------------|--------------------------------------------------------------------------------------------------------------------------------------------|
| ANSI/TIA-603-C: 2004 | Land Mobile FM or PM Communications Equipment Measurement and Performance Standards |
| 3GPP TS51.010 V5.4.0.0:2005 | Digital cellular telecommunications system Mobile Station (MS) conformance specification; |
| 3GPP TS 34.121 V8.7.0:2009 | Technical Specification Group Radio Access Network; User Equipment (UE) conformance specification; Radio transmission and reception (FDD); |

6.3.2.3 Limits

No specific modulation characteristics requirement limits in part 2.1047 and part 22 subpart H.

Table 23 Limits

| | |
|--------|----------------|
| Limits | Not applicable |
|--------|----------------|

6.3.3 Test Method and Setup

Connect the HUAWEI MU509-c Module to Universal Radio Communication Tester CMU200 via the antenna connector. The frequency band is set as 850M; the HUAWEI MU509-c Module's output is matched with 50 Ω load, test method was according to 3GPP TS 51.010 and 3GPP TS 34.121. The waveform quality and constellation of the HUAWEI MU509-c Module was tested.

Test setup

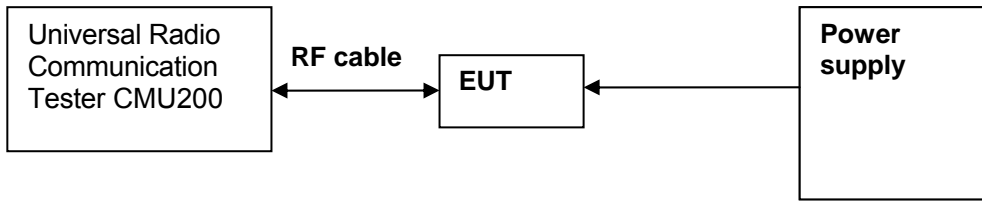

Figure 3. Test Set-up

6.3.4 Measurement Results

Table 24 Measurement Results

| | | Modulation Characteristic | |
|--------------------------|-------------------------|----------------------------|---------------------|
| TEST CONDITIONS | | Channel Middle | |
| | | Measured | |
| | | TM1 | TM2 |
| T _{nom} (25 °C) | V _{nom} (3.8V) | Refer to Appendix A | Refer to Appendix A |
| | | Modulation Characteristic | |
| TEST CONDITIONS | | Channel4182(M) 836.4MHz | |
| | | Measured | |
| | | TM3 | |
| T _{nom} (25 °C) | V _{nom} (3.8V) | Refer to Appendix A | |

6.3.5 Conclusion

The equipment **PASSED** the requirement of this clause.

For the measurement results refer to appendix A.

6.4 Occupied Bandwidth

6.4.1 Test Conditions

Table 25 Test Conditions

| | |
|----------------------|----------------------------------------------|
| Preconditioning: | 0.5 hour |
| Measured at: | Antenna connector |
| Ambient temperature: | 25 °C |
| Relative humidity: | 55 % |
| Test Configurations: | TM1/TM2/TM3 at frequency Bottom, Middle, Top |

6.4.2 Test Specifications and Limits

6.4.2.1 Specification

CFR 47 (FCC) part 2.1049 and part 22 subpart H.

6.4.2.2 Supporting Standards

Table 26 Supporting Standards:

| | |
|-----------------------------|--------------------------------------------------------------------------------------------------------------------------------------------|
| ANSI/TIA-603-C: 2004 | Land Mobile FM or PM Communications Equipment Measurement and Performance Standards |
| 3GPP TS51.010 V5.4.0.0:2005 | Digital cellular telecommunications system Mobile Station (MS) conformance specification; |
| 3GPP TS 34.121 V8.7.0:2009 | Technical Specification Group Radio Access Network; User Equipment (UE) conformance specification; Radio transmission and reception (FDD); |

6.4.2.3 Limits

No specific occupied bandwidth requirement in part 22 subpart H, but the occupied bandwidth was defined in part 2.1049: the frequency bandwidth such that, below its lower and above its upper frequency limits, the mean powers radiated are each equal to 0.5 percent of the total mean power radiated by a given emission shall be measured.

Table 27 Limits

| | |
|-------------------------------|------------------------|
| Upper /lower frequency limits | 0.5% of the mean power |
|-------------------------------|------------------------|

6.4.3 Test Method and Setup

HUAWEI MU509-c Module was connected to the wireless signal analyzer R&S FSU26 via the one RF connector. The band class is set as 850M; HUAWEI MU509-c Module was controlled to transmit maximum power. Measure and record the occupied bandwidth of the HUAWEI MU509-c Module by the R&S FSU26.

The OBW, that is the frequency bandwidth such that, below its lower and above its upper frequency limits, the mean powers radiated are each equal to 0.5 percent of the total mean power radiated by a given emission shall be measured under the following conditions as applicable:

Refer to 47CFR part2.1049 section (g)&(h).

(g) Transmitter in which the modulating base band comprises not more than three independent channels - when modulated by the full complement of signals for which the transmitter is rated. The level of modulation for each channel should be set to that prescribed in rule parts applicable to the services for which the transmitter is intended. If specific modulation levels are not set forth in the rules, the tests should provide the manufacturer's maximum rated condition.

(h) Transmitters employing digital modulation techniques - when modulated by an input signal such that its amplitude and symbol rate represent the maximum rated conditions under which the equipment will be operated. The signal shall be applied through any filter networks, pseudorandom generators or other devices required in normal service. Additionally, the occupied bandwidth shall be shown for operation with any devices used for modifying the spectrum when such devices are optional at discretion of the user.

For TM1/TM2 following RBW and VBW are employed:
 Measurement bandwidth (RBW): 3 kHz (Resolution bandwidth)
 Video bandwidth (VBW): 10 kHz

For TM3 following RBW and VBW are employed:
 Measurement bandwidth (RBW): 50 kHz (Resolution bandwidth)
 Video bandwidth (VBW): 500 kHz

Test Set-up

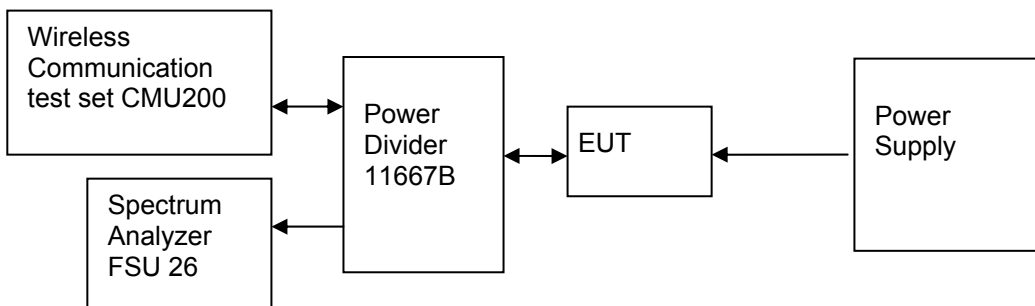

Figure 4. Test Set-up

6.4.4 Measurement Results

Table 28 Measurement Results

| TEST CONDITIONS | | Occupied Bandwidth | | | | | |
|-----------------------------|-----|----------------------------|--------|----------------------------|--------|----------------------------|--------|
| Center Frequency | | Channel128(B) 824.2MHz | | Channel192(M) 837.0MHz | | Channel251(T) 848.8MHz | |
| | | Measured (kHz) | | Measured (kHz) | | Measured (kHz) | |
| | | TM1 | TM2 | TM1 | TM2 | TM1 | TM2 |
| Tnom (25 °C) Vnom (3.8V) | 99% | 243.59 | 248.40 | 246.79 | 245.19 | 245.19 | 245.19 |
| Center Frequency | | Channel4132(B) 826.4MHz | | Channel4182(M) 836.4MHz | | Channel4233(T) 846.6MHz | |
| | | Measured (MHz) | | Measured (MHz) | | Measured (MHz) | |



| | | TM3 | TM3 | TM3 |
|-----------------------------|-----|------|------|------|
| Tnom (25 °C) Vnom (3.8V) | 99% | 4.20 | 4.20 | 4.20 |

6.4.5 Conclusion

The equipment **PASSED** the requirement of this clause.
For the measurement results refer to appendix B.

6.5 Band Edges Compliance

6.5.1 Test Conditions

Table 29 Test Conditions

| | |
|----------------------|--------------------------------------|
| Preconditioning: | 0.5 hour |
| Measured at: | Antenna connector |
| Ambient temperature: | 25°C |
| Relative humidity: | 55 % |
| Test Configurations: | TM1/TM2/TM3 at frequency Bottom, Top |

6.5.2 Test Specifications and Limits

6.5.2.1 Specification

CFR 47 (FCC) part 2.1051 and part 22 subpart H

6.5.2.2 Supporting Standards

Table 30 Supporting Standards:

| | |
|-----------------------------|--------------------------------------------------------------------------------------------------------------------------------------------|
| ANSI/TIA-603-C: 2004 | Land Mobile FM or PM Communications Equipment Measurement and Performance Standards |
| 3GPP TS51.010 V5.4.0.0:2005 | Digital cellular telecommunications system Mobile Station (MS) conformance specification; |
| 3GPP TS 34.121 V8.7.0:2009 | Technical Specification Group Radio Access Network; User Equipment (UE) conformance specification; Radio transmission and reception (FDD); |

6.5.2.3 Limits

Compliance with part 22.917, all spurious emission must be attenuated below the transmitter power by at least $43 + 10 \log_{10} P (W)$. (Whereas P is the rated power of the EUT).

Table 31 Limits

| | TM1 | TM2 | TM3 |
|-----------------------|--------------------------------------------|----------------------------------------------|-----------------------------------------------|
| Rated Power: | 33 dBm | 27 dBm | 24 dBm |
| Required attenuation: | $43 + 10 \log(2) = 46$, 33 dBm - 46 dB | $43 + 10 \log(0.5) = 40$, 27 dBm - 40 dB | $43 + 10 \log(0.25) = 37$, 24 dBm - 37 dB |
| Absolute level | - 13 dBm | - 13 dBm | - 13 dBm |

6.5.3 Test Method and Setup

HUAWEI MU509-c Module was connected to the wireless signal analyzer R&S FSU26 via the one RF connector, the band class is set as 850M. HUAWEI MU509-c Module was controlled to transmit

maximum power. Measure and record band edges compliance of the HUAWEI MU509-c Module by the R&S FSU26.

For TM1/TM2 following RBW and VBW are employed:
 Measurement bandwidth (RBW): 3 kHz (Resolution bandwidth)
 Video bandwidth (VBW): 10 kHz
 For TM3 following RBW and VBW are employed:
 Measurement bandwidth (RBW): 50 kHz (Resolution bandwidth)
 Video bandwidth (VBW): 200 kHz

Test Set-up

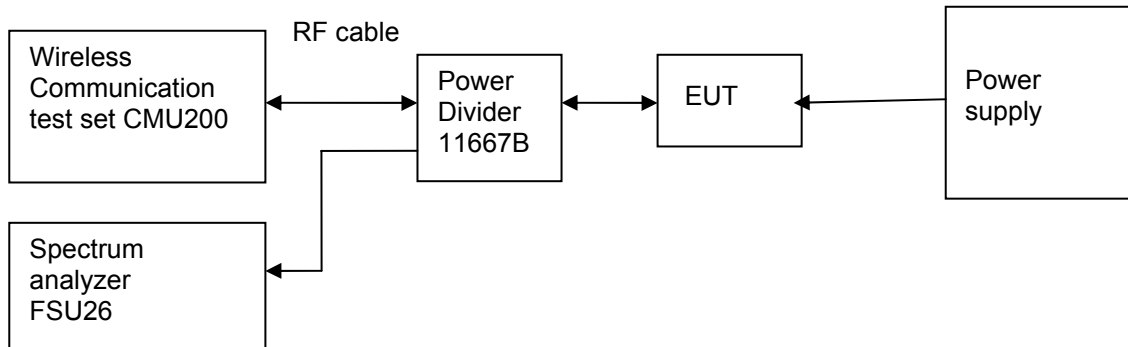

Figure 5. Test Set-up

6.5.4 Measurement Results

Table 32 Measurement Results outside Band Edges-- Single Carrier

| Band | Frequency of Band edges [MHz] | Channel Number | Test Mode | Spurious Level measured [dBm] | FCC limit | Result |
|-------------------------------------|-------------------------------|----------------|-----------|-------------------------------|-----------|--------|
| T_{nom} (25 °C), V_{nom} (3.8V) | | | | | | |
| Cellular | 824.2 | 128 | TM1 | <-13(See appendix C) | - 13 dBm | Pass |
| | 848.8 | 251 | TM1 | <-13(See appendix C) | - 13 dBm | Pass |
| | 824.2 | 128 | TM2 | <-13(See appendix C) | - 13 dBm | Pass |
| | 848.8 | 251 | TM2 | <-13(See appendix C) | - 13 dBm | Pass |
| | 826.4 | 4132 | TM3 | <-13(See appendix C) | - 13 dBm | Pass |
| | 846.6 | 4233 | TM3 | <-13(See appendix C) | - 13 dBm | Pass |

6.5.5 Conclusion

The equipment **PASSED** the requirement of this clause.



For the measurement results refer to appendix C.

6.6 Spurious Emission at Antenna Terminal

6.6.1 Test Conditions

Table 33 Test Conditions

| | |
|----------------------|----------------------------------------------|
| Preconditioning: | 0.5 hour |
| Measured at: | Antenna connector |
| Ambient temperature: | 25°C |
| Relative humidity: | 50 % |
| Test Configurations: | TM1/TM2/TM3 at frequency Bottom, Middle, Top |

6.6.2 Test Specifications and Limits

6.6.2.1 Specification

CFR 47 (FCC) part 2.1051 and part 22 subpart H

6.6.2.2 Supporting Standards

Table 34 Supporting Standards:

| | |
|-----------------------------|--------------------------------------------------------------------------------------------------------------------------------------------|
| ANSI/TIA-603-C: 2004 | Land Mobile FM or PM Communications Equipment Measurement and Performance Standards |
| 3GPP TS51.010 V5.4.0.0:2005 | Digital cellular telecommunications system Mobile Station (MS) conformance specification; |
| 3GPP TS 34.121 V8.7.0:2009 | Technical Specification Group Radio Access Network; User Equipment (UE) conformance specification; Radio transmission and reception (FDD); |

6.6.2.3 Limits

Compliance with part 22.917, all spurious emission must be attenuated below the transmitter power by at least $43 + 10 \log_{10} P$. (Whereas P is the rated power of the EUT).

Table 35 Limits

| | TM1 | TM2 | TM3 |
|-----------------------|--------------------------------------|----------------------------------------|-----------------------------------------|
| Rated Power: | 33dBm | 27 dBm | 24 dBm |
| Required attenuation: | $43+10\log(2) = 46$, 33 dBm - 46 dB | $43+10\log(0.5) = 40$, 27 dBm - 40 dB | $43+10\log(0.25) = 37$, 24 dBm - 37 dB |
| Absolute level | - 13 dBm | - 13 dBm | - 13 dBm |

6.6.3 Test Method and Setup

HUAWEI MU509-c Module was connected to the wireless signal analyzer R&S FSU26 via the one RF connector, the band class is set as 850M. HUAWEI MU509-c Module was controlled to transmit

maximum power. Measure and record the Conducted Spurious Emission of the HUAWEI MU509-c Module by the R&S FSU26.

According to part 22.917, the defined measurement bandwidth as following:

22.917 (b) Measurement procedure: Compliance with these provisions is based on the use of measurement instrumentation employing a resolution bandwidth of 100 kHz or greater.

- Measurement bandwidth (RBW) for 9 kHz up to 150 KHz: 1 kHz;
- Measurement bandwidth (RBW) for 150 kHz up to 30 MHz: 10 kHz;
- Measurement bandwidth (RBW) for 30 MHz up to 1 GHz: 100 kHz;
- Measurement bandwidth (RBW) for 1 GHz up to 12.75 GHz: 1 MHz;

Test Set-up

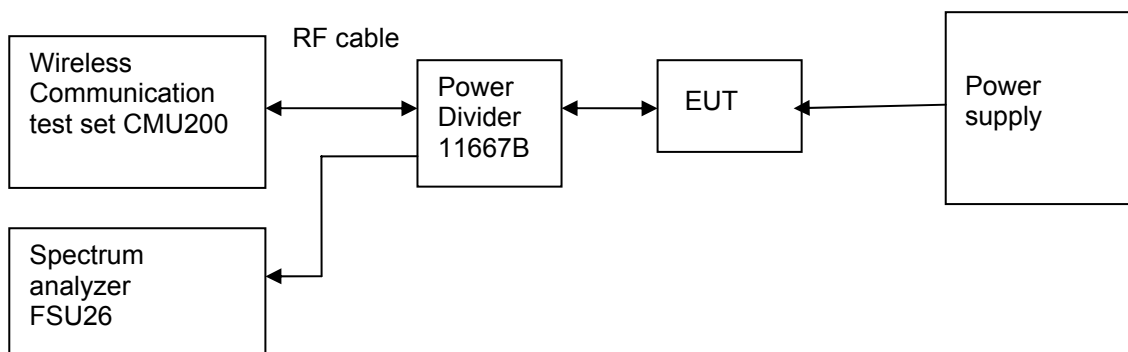

Figure 6. Test Set-up

6.6.4 Measurement Results

Table 36 Measurement Results

| Channel Number | Test Mode | Test Range (Frequency) | Output Power [dBm] | Spurious Level measured [dBm] | FCC limit | Result |
|-----------------|-----------|------------------------|--------------------|-------------------------------|-----------|--------|
| Channel 128(B) | TM1 | 9 kHz ~12.75GHz | 33 | <- 13 dBm (See appendix D) | - 13 dBm | Pass |
| | TM2 | 9 kHz ~12.75GHz | 27 | <- 13 dBm (See appendix D) | - 13 dBm | Pass |
| Channel 4132(B) | TM3 | 9 kHz ~12.75GHz | 24 | <- 13 dBm (See appendix D) | - 13 dBm | Pass |
| Channel 192(M) | TM1 | 9 kHz ~12.75GHz | 33 | <- 13 dBm (See appendix D) | - 13 dBm | Pass |
| | TM2 | 9 kHz ~12.75GHz | 27 | <- 13 dBm (See appendix D) | - 13 dBm | Pass |
| Channel 4182(M) | TM3 | 9 kHz ~12.75GHz | 24 | <- 13 dBm (See appendix D) | - 13 dBm | Pass |



| | | | | | | |
|--------------------|-----|--------------------|----|-------------------------------|-------------|------|
| Channel 251(T) | TM1 | 9 kHz ~12.75GHz | 33 | <- 13 dBm (See appendix D) | - 13 dBm | Pass |
| | TM2 | 9 kHz ~12.75GHz | 27 | <- 13 dBm (See appendix D) | - 13 dBm | Pass |
| Channel 4233(T) | TM3 | 9 kHz ~12.75GHz | 24 | <- 13 dBm (See appendix D) | - 13 dBm | Pass |

6.6.5 Conclusion

The equipment **PASSED** the requirement of this clause.
For the measurement results refer to appendix D.

6.7 Frequency Stability

6.7.1 Test Conditions

Table 37 Test Conditions

| | |
|----------------------|---------------------------------|
| Preconditioning: | 0.5 hour |
| Measured at: | Antenna connector |
| Ambient temperature: | See below |
| Relative humidity: | 55 % at 25 °C |
| Test Configurations: | TM1/TM2/TM3 at frequency Middle |

6.7.2 Test Specifications and Limits

6.7.2.1 Specification

CFR 47 (FCC) part 2.1055 and part 22.355

6.7.2.2 Supporting Standards

Table 38 Supporting Standards:

| | |
|-----------------------------|--------------------------------------------------------------------------------------------------------------------------------------------|
| ANSI/TIA-603-C: 2004 | Land Mobile FM or PM Communications Equipment Measurement and Performance Standards |
| 3GPP TS51.010 V5.4.0.0:2005 | Digital cellular telecommunications system Mobile Station (MS) conformance specification; |
| 3GPP TS 34.121 V8.7.0:2009 | Technical Specification Group Radio Access Network; User Equipment (UE) conformance specification; Radio transmission and reception (FDD); |

6.7.2.3 Limits

According to part 22.355, from 821MHz to 896MHz, for mobile device, the carrier frequency of each transmitter in the Public Mobile Services must be maintained within the tolerances 2.5ppm.

6.7.3 Test Method and Setup

The frequency stability shall be measured with variation of ambient temperature as follows:

- (1) From -30 ° to +70 ° centigrade for all equipment except that specified in subparagraphs
- (2) and (3) of paragraph 2.1055

(a) Frequency measurements shall be made at the extremes of the specified temperature range and at intervals of not more than 10° centigrade through the range. A period of time sufficient to stabilize all of the components of the oscillator circuit at each temperature level shall be allowed prior to frequency measurement. The short-term transient effects on the frequency of the transmitter due to keying (except for broadcast transmitters) and any heating element cycling normally occurring at each ambient temperature level also shall be shown. Only the portion or portions of the transmitter containing the frequency determining and stabilizing circuitry need be subjected to the temperature variation test.

(b) The frequency stability shall be measured with variation of primary supply voltage as follows:

- (1) Vary primary supply voltage from 95 to 105 percent of the nominal value for other than hand carried battery equipment.
- (2) For hand carried, battery powered equipment, reduce primary supply voltage to the battery operating end point, which shall be specified by the manufacturer.

(3) The supply voltage shall be measured at the input to the cable normally provided with the equipment, or at the power supply terminals if cables are not normally provided. Effects on frequency of transmitter keying (except for broadcast transmitters) and any heating element cycling at the nominal supply voltage and at each extreme also shall be shown.

(c) When deemed necessary, the Commission may require tests of frequency stability under conditions in addition to those specifically set out in paragraphs (a), (b), (c) of this section. (For example, measurements showing the effect of proximity to large metal objects, or of various types of antennas, may be required for portable equipment.)

The EUT can only work in such extreme voltage 3.3V and 4.2V, so here the EUT is tested in the 3.3V and 4.2V.

Test Set up

Connect the HUAWEI MU509-c Module to the Wireless Communication test set CMU200 via the connector. Then measure the frequency error by the Wireless Communication test set CMU200. The EUT's output is matched with a 50 Ω load.

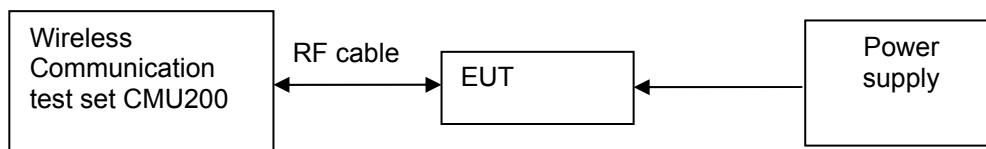

Figure 7. Test Set up

6.7.4 Measurement Results

6.7.4.1 Measurement Results vs. Variation of Temperature

- **TM1, 3.8V DC Channel No.192(837.0MHz)**

Table 39 Measurement Results vs. Variation of Temperature—TM1

| Temperature | Nominal Frequency (MHz) | Measured Frequency Error(Hz) | Result |
|-------------|----------------------------|---------------------------------|--------|
| -30 °C | 837.0 | 33 | Pass |
| -20 °C | 837.0 | -23 | Pass |
| -10 °C | 837.0 | -13 | Pass |
| 0 °C | 837.0 | 11 | Pass |
| +10 °C | 837.0 | -4 | Pass |
| +20 °C | 837.0 | -9 | Pass |
| +30 °C | 837.0 | -10 | Pass |
| +40 °C | 837.0 | -7 | Pass |
| +50 °C | 837.0 | 18 | Pass |
| +60 °C | 837.0 | -9 | Pass |
| +70 °C | 837.0 | 8 | Pass |

● **TM2, 3.8V DC Channel No.192(837.0MHz)**

Table 40 Measurement Results vs. Variation of Temperature – TM2

| Temperature | Nominal Frequency (MHz) | Measured Frequency Error(Hz) | Result |
|-------------|----------------------------|---------------------------------|--------|
| -30 °C | 837.0 | 31 | Pass |
| -20 °C | 837.0 | -25 | Pass |
| -10 °C | 837.0 | -10 | Pass |
| 0 °C | 837.0 | 6 | Pass |
| +10 °C | 837.0 | 10 | Pass |
| +20 °C | 837.0 | 1 | Pass |
| +30 °C | 837.0 | 6 | Pass |
| +40 °C | 837.0 | -13 | Pass |
| +50 °C | 837.0 | 14 | Pass |
| +60 °C | 837.0 | 7 | Pass |
| +70 °C | 837.0 | -8 | Pass |

● **TM3, 3.8V DC Channel No.4182(836.4MHz)**

Table 41 Measurement Results vs. Variation of Temperature – TM3

| Temperature | Nominal Frequency (MHz) | Measured Frequency Error(Hz) | Result |
|-------------|----------------------------|---------------------------------|--------|
| -30 °C | 836.4 | 27 | Pass |
| -20 °C | 836.4 | 23 | Pass |
| -10 °C | 836.4 | -14 | Pass |
| 0 °C | 836.4 | -8 | Pass |
| +10 °C | 836.4 | 4 | Pass |
| +20 °C | 836.4 | 7 | Pass |
| +30 °C | 836.4 | -6 | Pass |
| +40 °C | 836.4 | -7 | Pass |
| +50 °C | 836.4 | 13 | Pass |
| +60 °C | 836.4 | 6 | Pass |
| +70 °C | 836.4 | 8 | Pass |

6.7.4.2 Measurement Results vs. Variation of Voltage

● **TM1, 25 °C ,Channel No. 192(837.0MHz)**

Table 42 Measurement Results vs. Variation of Voltage—TM1

| Voltage | Nominal Frequency (MHz) | Measured Frequency Error(Hz) | Result |
|---------|----------------------------|---------------------------------|--------|
| 4.2 V | 837.0 | -16 | Pass |
| 3.8 V | 837.0 | -21 | Pass |
| 3.3 V | 837.0 | -24 | Pass |

● **TM2, 25 °C ,Channel No. 192(837.0MHz)**

Table 43 Measurement Results vs. Variation of Voltage—TM2

| Voltage | Nominal Frequency (MHz) | Measured Frequency Error(Hz) | Result |
|---------|----------------------------|---------------------------------|--------|
| 4.2 V | 837.0 | -31 | Pass |
| 3.8 V | 837.0 | -34 | Pass |
| 3.3 V | 837.0 | -36 | Pass |

● **TM3, 25 °C ,Channel No. 4182(836.4MHz)**

Table 44 Measurement Results vs. Variation of Voltage—TM3

| Voltage | Nominal Frequency (MHz) | Measured Frequency Error(Hz) | Result |
|---------|----------------------------|---------------------------------|--------|
| 4.2 V | 836.4 | -19 | Pass |
| 3.8 V | 836.4 | -6 | Pass |
| 3.3 V | 836.4 | -1 | Pass |

6.7.5 Conclusion

The equipment **PASSED** the requirement of this clause.



7 System Measurement Uncertainty

For a 95% confidence level, the measurement expanded uncertainties for defined systems, in accordance with the recommendations of ISO 17025 as following:

Table 45 System Measurement Uncertainty

| Items | | Extended Uncertainty |
|-------------------------------------------------|-------------------------|----------------------|
| Effective Radiated Power of Transmitter | EIRP (dBm) | U=3dB; k=2 |
| Band Width | Magnitude (%) | U=0.2%; k=2 |
| Band Edge Compliance | Disturbance Power (dBm) | U=2.0dB; k=2 |
| Conducted Spurious Emission at Antenna Terminal | Disturbance Power (dBm) | U=2.0dB; k=2 |
| Frequency Stability | Frequency Accuracy(ppm) | U=0.21ppm; k=2 |



8 Appendices

| | | |
|------------|-----------------------------------------------------------|----------|
| Appendix A | Measurement Results Modulation Characteristics | 4 Pages |
| Appendix B | Measurement Results Occupied Bandwidth | 10 Pages |
| Appendix C | Measurement Results Band Edges | 7 Pages |
| Appendix D | Measurement Results Spurious Emission at Antenna Terminal | 37 Pages |