

AirLine MICRO  
ESM

Earset Wireless System

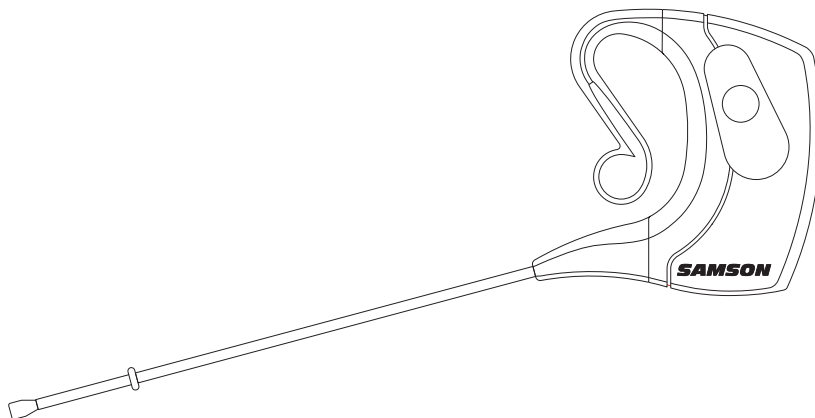

OWNER'S MANUAL

**SAMSON®**



If you want to dispose this product, do not mix it with general household waste. There is a separate collection system for used electronic products in accordance with legislation that requires proper treatment, recovery and recycling.

Private household in the 27 member states of the EU, in Switzerland and Norway may return their used electronic products free of charge to designated collection facilities or to a retailer (if you purchase a similar new one).

For Countries not mentioned above, please contact your local authorities for a correct method of disposal.

By doing so you will ensure that your disposed product undergoes the necessary treatment, recovery and recycling and thus prevent potential negative effects on the environment and human health.

Copyright 2024, Samson Technologies Corp V1.1

This product is covered by the US patent: US9,602,053

Samson Technologies Corp.  
278-B Duffy Ave  
Hicksville, NY 11801  
[www.samsontech.com](http://www.samsontech.com)

**SAMSON**

## Important Safety Information

1. Read these instructions.
2. Keep these instructions.
3. Heed all warnings.
4. Follow all instructions.
5. Do not use this apparatus near water.
6. Clean only with dry cloth.
7. Do not block any ventilation openings. Install in accordance with the manufacturer's instructions.
8. Do not install near any heat sources such as radiators, heat registers, stoves, or other apparatus (including amplifiers) that produce heat.
9. Do not defeat the safety purpose of the polarized or grounding type plug. A polarized plug has two blades with one wider than the other. A grounding type plug has two blades and a third grounding prong. The wide blade or the third prong are provided for your safety. If the provided plug does not fit into your outlet, consult an electrician for replacement of the obsolete outlet.
10. Protect the power cord from being walked on or pinched, particularly at the plugs, convenience receptacles, and at the point where they exit from the apparatus.
11. Only use attachments/accessories specified by the manufacturer.
12. Use only with the cart, stand, tripod, bracket, or table specified by the manufacturer, or sold with the apparatus. When a cart is used, use caution when moving the cart/apparatus combination to avoid injury from tip-over.
13. Unplug the apparatus during lightning storms or when unused for long periods of time.
14. Refer all servicing to qualified personnel. Service is required when the apparatus has been damaged in any way, such as power supply cord or plug is damaged, liquid has been spilled or objects have fallen into the apparatus, the apparatus has been exposed to rain or moisture, does not operate normally, or has been dropped.
15. Do not expose the apparatus to dripping or splashing water. Do not place an object filled with liquid, such as vases, on the apparatus.
16. Caution-to prevent electrical shock, match wide blade with the plug's wide slot, fully insert.
17. Please keep the area around the entire unit properly ventilated.
18. The mains plug or appliance coupler shall remain readily operable.
19. Batteries (battery pack or batteries installed) shall not be exposed to excessive heat such as sunshine, fire or the like.



# Important Safety Information

## FCC Rules and Regulations

Samson wireless receivers are certified under FCC Rules part 15 and transmitters are certified under FCC Rules part 74. Licensing of Samson equipment is the user's responsibility and licensability depends on the user's classification, application and frequency selected.

This device complies with Part 15 of the FCC rules Class B and RSS-210 of Industry & Science Canada.

Operation is subject to the following two conditions:

- (1) This device must not cause harmful interference, and
- (2) This device must accept any interference received including interference that may cause undesired operation. Suitable for home or office use.

NOTE: This equipment has been tested and found to comply with the limits for a Class B digital device, pursuant to Part 15 of the FCC Rules. These limits are designed to provide reasonable protection against harmful interference in a residential installation. This equipment generates, uses and can radiate radio frequency energy and, if not installed and used in accordance with the instructions, may cause harmful interference to radio communications. However, there is no guarantee that interference will not occur in a particular installation. If this equipment does cause harmful interference to radio or television reception, which can be determined by turning the equipment off and on, the user is encouraged to try to correct the interference by one or more of the following measures:

- Reorient or relocate the receiving antenna.
- Increase the separation between the equipment and receiver.
- Connect the equipment into an outlet on a circuit different from that to which the receiver is connected.
- Consult the dealer or an experienced Radio/TV technician for help.

WARNING: Changes or modifications not expressly approved by the party responsible for compliance could void the user's authority to operate the equipment.

This equipment is intended for use in wireless microphone applications.

Equipment is intended for sale in: AT, BE, CH, CY, CZ\*, DK, EE, FI\*, FR\*, DE\*, GR\*, HU, IE, IS, IT, LV, LT\*, LU, MT\*, NL, NO\*, PL\* PT, RO, SK, SI, ES, SE, UK

\*Subject to license. Please contact your national frequency authority for information on available legal use in your area. Any changes or modifications not expressly approved by Samson Technologies Corp. could void your authority to operate the equipment.

Hereby, Samson Technologies Corp., declares that this AR99m and AH100 is in compliance with the essential requirements and other relevant provisions of Directive 2014/53/EU. The declaration of conformity may be consulted at:

[http://www.samsontech.com/site\\_media/support/manuals/AirlineEsm\\_DOC.pdf](http://www.samsontech.com/site_media/support/manuals/AirlineEsm_DOC.pdf)

**SAMSON**

# Introduction

Welcome to Samson AirLine, the original micro-wireless microphone systems. Wireless microphone and instrument systems were originally developed to eliminate cables, providing unparalleled freedom of movement. AirLine ESm takes this concept to a new level with frequency agile transmitters and mini receiver, providing a completely hassle-free user experience.

Featuring miniaturized circuitry and an internal rechargeable battery, the AH100 can operate for up to 8 hours on a single charge. The AirLine ESm System combines an AH100 transmitter with a Samson SE100 low-profile earset microphone.

Offering frequency-agile UHF operation, the mini-sized True RF Diversity AR99m receiver provides 100 available channels to secure reliable wireless performance. The receiver provides easy setup with 1-touch scan which analyzes and selects the clearest operating channel, infrared set to pair the transmitter with the receiver, and versatile output connections (XLR, 1/4" and 1/8"). An included USB port can be used to charge the AH100 transmitter or integrate a Samson XPD Series wireless system (sold separately) to make it a dual-receiver.

In these pages, you'll find a detailed description of the features of the AirLine ESm System, as well as step-by-step instructions for its setup and use. If your wireless system was purchased in the United States, you'll also find a registration card enclosed—don't forget to follow the instructions so that you can receive online technical support, updated information about this product and other Samson products in the future. Also, be sure to check out our website [www.samsontech.com](http://www.samsontech.com) for complete information about our full product line.

We recommend you keep the following records for reference, as well as a copy of your sales receipt:

Receiver Serial number: \_\_\_\_\_

Transmitter Serial number: \_\_\_\_\_

Date of purchase: \_\_\_\_\_

If you have any questions or comments regarding the AirLine ESm Microphone System or any other products from Samson, do not hesitate to contact us at [support@samsontech.com](mailto:support@samsontech.com).

With proper care and maintenance, your AirLine 99m System will operate trouble-free for many years. Should your AirLine ESm System ever require servicing, a Return Authorization (RA) number must be obtained before shipping your unit to Samson. Without this number, the unit will not be accepted. Please visit [www.samsontech.com/ra](http://www.samsontech.com/ra) for an RA number prior to shipping your unit. Please retain the original packing materials and, if possible, return the unit in its original carton. If your AirLine ESm System was purchased outside of the United States, contact your local distributor for warranty details and service information.

**AirLine Micro ESm Earset System**

# AR99m Receiver Features

- Antennas** - The antenna mountings allow full rotation for optimum placement. In normal operation, both antennas should be placed in a vertical position. Both antennas can be folded inward for convenience when transporting the AR99m.
- SET Button** - Press this button for **more than 2 seconds** to enter scan mode. The display will flash quickly. The receiver will scan through the 100 operating channels to find the optimal channel for performance. Once the scan is complete, the AR99m will enter IR Set mode and send the selected channel to the transmitter. Press and hold the button for **more than 10 seconds** to enter IR set mode. The display will flash slowly. This will send the receiver's current selected channel to the transmitter.
- LED Display** - The two digit, 7-segment LED display shows the receiver's current operating channel.
- READY Indicator** - This indicator lights green when the AR99m is receiving RF signal and the system is ready to use.
- IR Transmitter** - During IR SET, an infrared light is used to set the transmitter channel.
- PEAK Indicator** - This indicator lights red when the transmitted audio signal is overloaded.
- VOLUME / Power Control** - This rotary knob controls the level of the receiver output and powers the AR99m on and off. Turn the control clockwise to turn the system on. Turn the knob counterclockwise until it clicks to turn the system off.
- USB Port** - This USB port provides 5V 200mA of power which can be used to charge the AH9 headset transmitter (AR99m only passes power to the USB port when the power is ON). It can also be used to connect an optional Samson XPD USB Digital Wireless receiver, turning the AR99m into a dual wireless system.

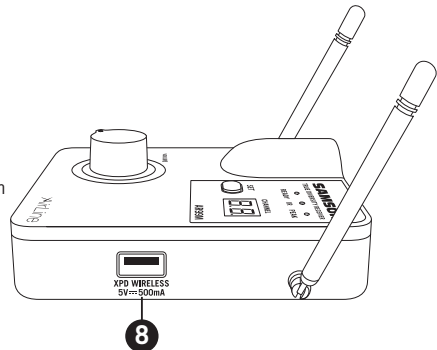
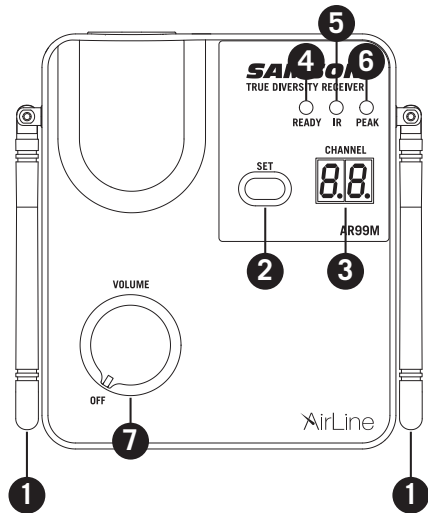

## AR99m Receiver Features Rear Panel

- DC Input** - Connect the supplied power adapter here.  
WARNING: Do not substitute any other kind of power adapter. Doing so can cause severe damage to the AR99m and will void your warranty.
- UNBALANCED OUTPUTS** - Use these unbalanced 1/4" and 1/8" jacks when connecting the AR99m to consumer (-10 dBV) audio equipment. Wiring is as follows: tip hot, sleeve ground.
- BALANCED OUTPUT** - Use this electronically balanced low impedance (600 Ohm) XLR jack when connecting the AR99m to professional (+4 dBu) audio equipment. Pin wiring is as follows: Pin 1 ground, Pin 2 high (hot), and Pin 3 low (cold).

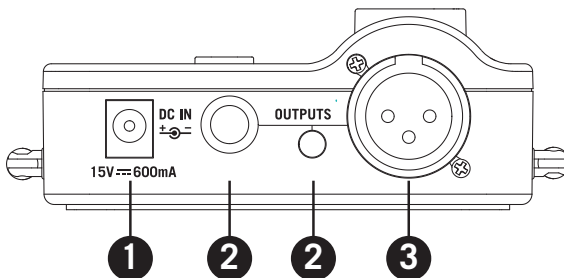

## AH100 Earset Transmitter Callouts

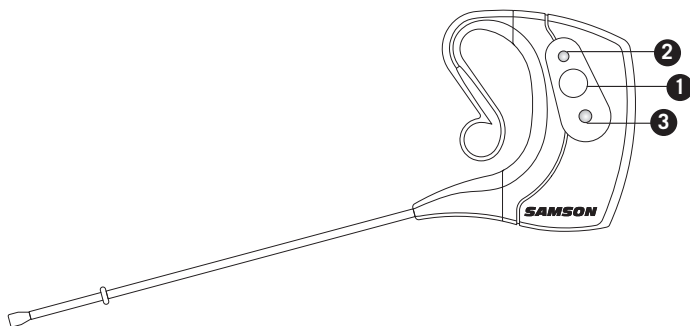

- Multifunction Button** - Press and hold for more than 2 seconds to turn the unit on, press and hold for more than 3 seconds to turn the unit off. A quick press will mute or un-mute the transmitter when the transmitter is on. Adjust volume by pressing and holding the button for more than 5 seconds, when the AH100 is powered off. The status LED will flash green slowly or rapidly depending on the volume level. Pressing the button will increase the volume (indicated by the speed of flashing LED). Wait 10 seconds to save the selected volume setting.
- Status LED** - This LED displays the operation mode, low battery and recharge status of the transmitter. The chart below defines the LED colors for each function.

GREEN	Normal Operation
FLASHING GREEN	Volume Adjustment Mode
AMBER	Mute
RED	During Use, Low Battery
FLASHING RED	Charging
RED	Fully Charged

- IR Lens** - This lens is used to capture the infrared signal sent from the receiver during IR SET which will sync the transmitter to the frequency selected by the AR99m receiver. The IR Lens is only active for the first 10 seconds when the transmitter is powered on.



## AH100 Earset Transmitter Callouts Continued



1. **Magnetic Connector** - Connect the supplied magnetic charging cable to this sealed, gold contact charging connector to recharge the internal Lithium Ion battery. The AH100 can be recharged by connecting the cable to the USB-A connector on the AR99m receiver or any 5-volt DC adapter that has a USB-A output.

## Wearing the AH100 Earset Microphone

As shown in the illustrations below, the AH100 can be adjusted to fit most (left) ears comfortably. The earhook is built with memory metal (internally) so it can be bent to fit securely without causing damage the AH100 Earset Transmitter.

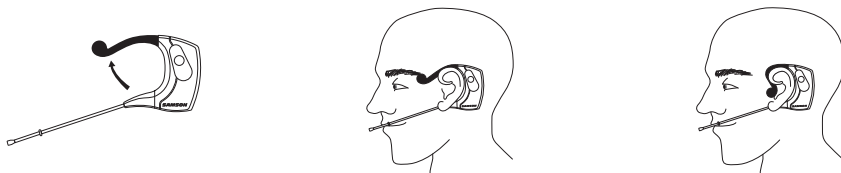

## Quick Start

In order for your wireless system to work correctly, both the receiver and transmitter must be set to the same channel. Follow this basic procedure to set up your AirLine ESm wireless system:

1. Physically place the AR99m receiver where it will be used, and extend the antennas vertically. The general rule of thumb is to maintain “line of sight” between the receiver and transmitter so the person using or wearing the transmitter can see the receiver.
2. Ensure the AH100 transmitter is fully charged (see section **Charging the AH100 Transmitter**).
3. With the AR99m powered off, connect the included power adapter.
4. With your amplifier or mixer off and volume control all the way down, connect the AR99m receiver output jack to the mic or line level input of a mixer or amplifier using the balanced XLR output or unbalanced 1/4” or 1/8” line level outputs. Turn the VOLUME knob on the AR99m clockwise to turn its power on, but keep the level low.
5. Press the SET button for more than 2 seconds. The display will start to flash quickly on the front of the AR99m receiver to scan for an available channel. Once the optimal channel is selected, the receiver will enter IR Set mode. The display will flash slowly in IR Set mode. If you want to set a transmitter to the receiver’s currently selected channel, press and hold the SET button for more than 10 seconds (until the display flashes slowly) to enter IR Set mode directly.
6. Turn on the power to the AH100 transmitter by pressing and holding the Power button for 2 seconds; the indicator LED will light green.
7. Position the AH100 transmitter about 3–12” (8–30 cm) from the top of the AR99m with the IR window facing the IR transmitter on the top panel of the AR99m receiver.
8. When the transmission of the operating channel is complete, the AR99m will receive RF signal and the READY indicator will light indicating that it is receiving wireless signal from the transmitter. Note: The AH100 will only accept infrared transmission from the receiver for the first 10 seconds after the AH100 is powered on. If you need to change the operating channel, the AH100 must be first powered off, then powered on again to receive the new channel.
9. Turn on your connected amplifier or mixer, but keep the volume all the way down. Set the Volume knob on the AR99m fully clockwise. This is unity gain. Speak or sing into the microphone at normal performance level. Slowly raise the volume of your amplifier or mixer until the desired level is reached.
10. When using multiple systems, each system must be set to a different operating channel. Follow these steps to set each receiver and transmitter to the optimal channel.

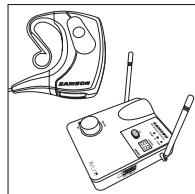
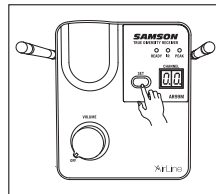

# Charging the AH100 Transmitter

1. With the AR99m powered off, connect the included power adapter.
2. Insert the magnetic power cable to the AR99m USB Port (or any 5-volt DC adapter that has a USB port).
3. Turn the VOLUME knob on the AR99m clockwise to turn its power on.
4. Place the AH100 transmitter on a flat surface.
5. Attach the magnetic connector to the gold contact power port on the bottom of the AH100 transmitter. The cable attaches to the port magnetically. The magnetic connector is keyed so it will only connect in one direction.  
*Note: Transmission is disabled during charging.*
6. Look at the indicator light on the AH100 transmitter to determine when the transmitter has finished charging. When the light is flashing red, the AH100 is charging. When the red light stops flashing (solid color LED) it indicates that the AH100 is fully charged.
7. Disconnect the magnetic power cable from the AH100 when the unit is fully charged.

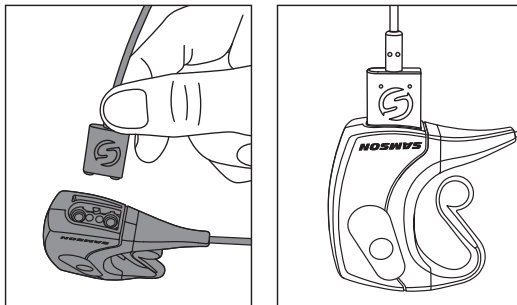

## Getting the most out of the rechargeable battery:

- Completely charge the batteries before first use
- Fully charge the battery before it will be used.
- After the battery is charged, unplug the charger from the outlet.
- The optimal temperature range for using and storing the battery is 50°F - 86°F (30°C - 50°C). The battery performance and operation may decrease in temperatures below 50°F (30°C).

## Connecting XPD Wireless

1. Plug the XPD USB receiver into the USB jack on the side of the AR99m receiver.
2. Place a fresh set of AA (LR6) batteries in the transmitter battery holder, taking care to observe the polarity markings.
3. Turn the AR99m receiver on by rotating the VOLUME control clockwise. The AR99m VOLUME control will affect the mix of the AH100 and XPD transmitters.
4. Turn on the power to the XPD transmitter by pressing and holding Power switch; the indicator LED will light amber.
5. If the transmitter and receiver have not been previously paired, press and hold the button on the XPD receiver for >5 seconds, until it begins to flash. Press and continue to hold the Power button on the transmitter until the LED indicators on both units light steady, indicating that the receiver and transmitter are paired and ready for operation.
6. Speak or sing into the microphone at a normal performance level and raise the AR99m VOLUME control until the desired level is reached.
7. To balance the level between the AH100 and XPD transmitter, use the supplied screwdriver to adjust the Gain control inside the XPD battery compartment. If you hear distortion from the XPD transmitter turn down the Gain. Conversely, if you hear a weak, noisy signal at the desired volume level, turn the Gain control in the XPD transmitter slowly clockwise until the signal reaches an acceptable level.

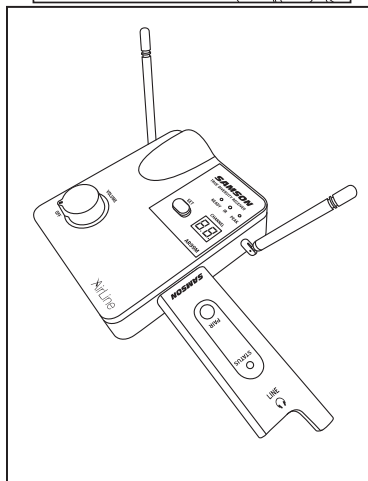
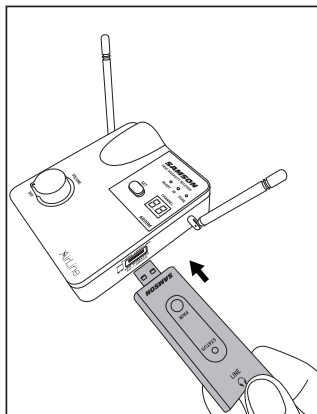

# Operating Bands and Frequency Ranges

Band	Frequency Range
K <sup>a</sup>	470–494 MHz
C <sup>a</sup>	500–524 MHz
G*	863–865 MHz

\* Not for use in the USA and Canada.

## European Frequency Operation

Note: This equipment is intended for professional musical and similar applications, and may be capable of operating on some frequencies not authorized in your region. Please contact your national authority to obtain information on authorized frequencies for wireless microphone products in your region.

Band	Frequency Range	Country Codes	Note
K <sup>a</sup>	470–494 MHz	AT, BE, BG, CY, CZ, DK, EE, FI, FR, DE, GR, HU, IS, IE, IT, LV, LT, LU, MT, NL, NO, PL, PT, RO, SK, SI, ES, SE, CH, UK, ZA, ID, MY, VN	See “a” below
C <sup>a</sup>	500–524 MHz	AT, BE, BG, CY, CZ, DK, EE, FI, FR, DE, GR, HU, IS, IE, IT, LV, LT, LU, MT, NL, NO, PL, PT, RO, SK, SI, ES, SE, CH, UK	License Free
G	863–865 MHz	AT, BE, BG, CY, CZ, DK, EE, FI, FR, DE, GR, HU, IS, IE, IT, LV, LT, LU, MT, NL, NO, PL, PT, RO, SK, SI, ES, SE, CH, UK	License Free

<sup>a</sup> Licensing: Note that a ministerial license to operate this equipment may be required in certain areas. Consult your national authority for possible requirements. Licensing of Samson wireless microphone equipment is the user’s responsibility, and licensability depends on the user’s classification and application, and on the selected frequency.

---

# Specifications

## System

Working Range	300' (100m) line of sight
Audio Frequency Response	75 Hz - 16 kHz
T.H.D. (Overall)	<0.4% THD+N @ 1kHz (re. -10 dBu, 22kHz BW)
Dynamic Range	>100 dB (re. + 4 dBu A-weighted)
Max System Gain	+42 dB

## AH100 Transmitter

Gain Steps -40 dBu @ 1 kHz	0 dBr (re. = -29 dBu) +10 dBr +15 dBr +18 dBr +22 dBr +25 dBr +27 dBr +29 dBr +31 dBr +6 dBu at minimum AH100 gain -26 dBu at maximum AH100 gain
Max Input @ 1 kHz	5mW EIRP
RF Power	3.7V 350mAh, 1.295Wh
Power Requirements	Lithium-Ion rechargeable battery 6 hours
Battery Life	6.9" x .62" x 2.46"
Dimensions (LxWxH)	177mm x 16mm x 62.5mm
Weight	.06lb / 28g

## Specifications Continued

### AR99m Receiver

Audio Output Level	
1/8" (3.5mm) & 1/4" (6.3mm) jack (unbalanced)	+14dBu
XLR jack (balanced)	+9dBu
Audio Output Impedance	
1/8" (3.5mm) & 1/4" (6.3mm) jack (unbalanced)	810 Ohms,
XLR output jack (balanced)	240 Ohms
Max Output	+13 dBu (1% THD+N)
Sensitivity	100dBm/30dB SINAD
Image Rejection	>50dB
Operating Voltage	15VCC 600mA
Dimensions (LxWxH)	4.3" x 3.74" x 1.5" 110mm x 95mm x 39mm
Weight	0.42lb / 192g

*At Samson, we are continually improving our products, therefore specifications and images are subject to change without notice.*

**Having Trouble with your AirLine ESm Wireless System?  
We can help!**



**CONTACT OUR SUPPORT TEAM: [support@samsontech.com](mailto:support@samsontech.com)  
Our experts can help you resolve any issues.**

Follow us:



**@samson\_technologies**



**@samson**

Samson Technologies  
278-B Duffy Ave  
Hicksville, NY 11801  
[www.samsontech.com](http://www.samsontech.com)