

FCU project

2.4G (BLE) ANTENNA DATASHEET

Table of Contents

1. Name and address of antenna manufacture
2. Antenna Specifications
3. 2.4 GHz (BLE) Antenna Model
4. Return Loss (RL) of BLE Antenna
5. 2D Far field Radiation Pattern
6. OTA passive test result
7. Test method
8. Calibration
9. Test Equipment
10. Summary

**1. Name and address of antenna manufacture:
Honeywell International Inc.**

2. BLE Antenna Specifications :

Parameters	Antenna
Antenna dimensions	15.5 x 6.9 mm
Max Gain	3.72 dBi
Return Loss min in band (S11)	< -10db
Band	2402-2480MHz
Max Efficiency	49%
Impedance	50 ohm
Antenna Diversity	No

Table 1 : specification

3. 2.4 GHz (BLE) Antenna Model



4. Return Loss (RL) of BLE Antenna

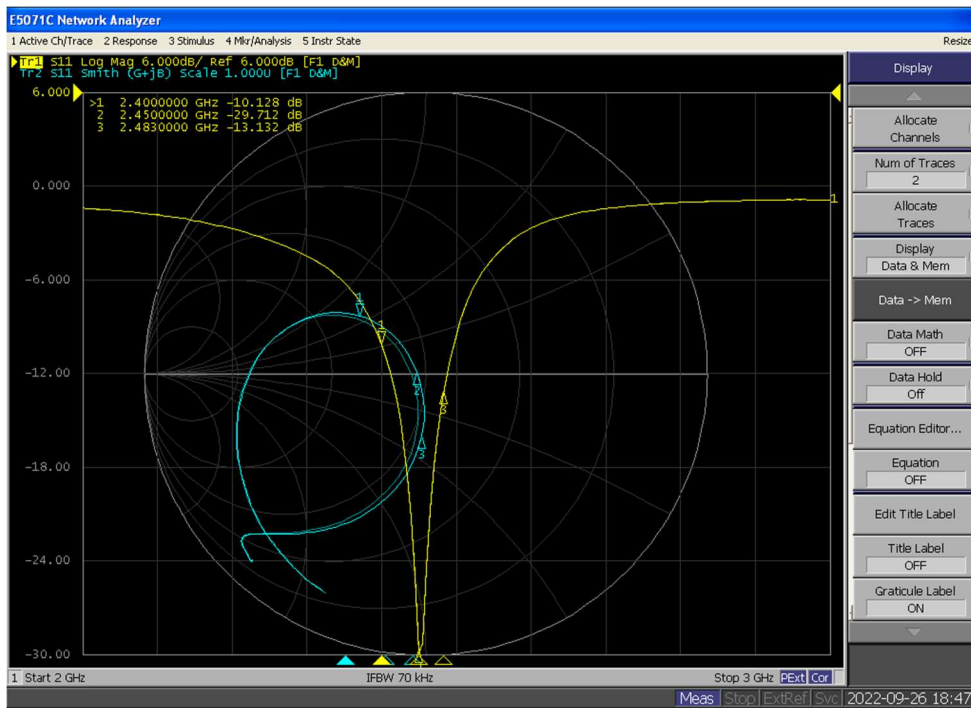

5. 2D Far field Radiation Pattern

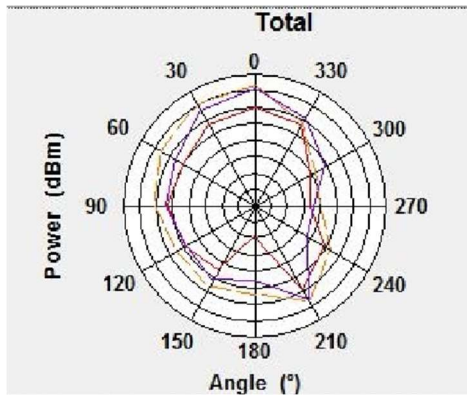

XY

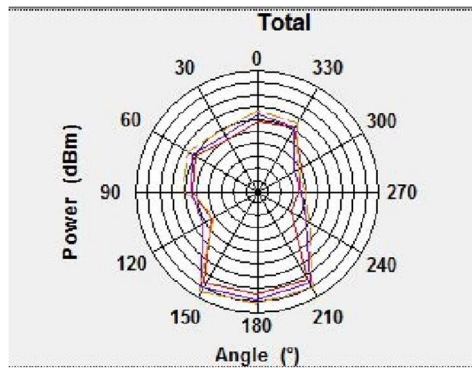

YZ

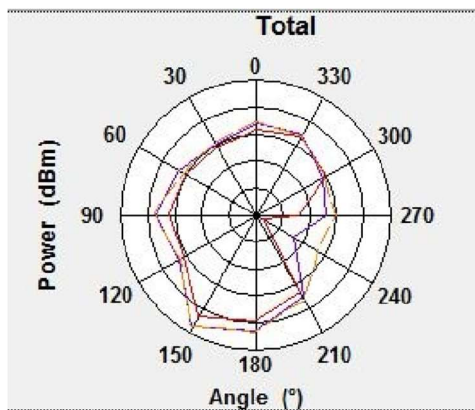

XZ

6. OTA passive test result

Frequency (MHz)	2400	2405	2410	2415	2420	2425	2430	2435	2440	2445	2450	2455	2460	2465	2470	2475	2480	2485	2490	2495	2500
Point Values	0	0	0	0	0	0	0	0	0	0	0	0	0	0	0	0	0	0	0	0	0
Ant. Port Input Pwr. (dBm)	-1.55073	-4.40541	-4.25964	-4.05731	-4.08739	-3.81536	-3.75126	-3.86044	-3.5579	-3.37009	-3.14376	-3.15004	-3.05175	-3.06105	-3.02605	-3.07481	-2.98452	-3.10055	-3.0202	-3.05986	-3.08747
Tot. Rad. Pwr. (dBm)	1.20984	2.08284	1.8628	1.94327	2.00509	2.4364	2.6474	2.59458	3.2405	2.8257	3.40825	3.49819	3.32397	3.55919	3.52257	3.72068	3.38846	3.26432	3.72578	3.79721	3.99256
Peak EIRP (dBm)	5.76057	6.48825	6.12244	6.00057	6.09248	6.25176	6.39865	6.45502	6.7984	6.1958	6.55202	6.64823	6.37572	6.62023	6.54862	6.7955	6.37298	6.36487	6.74597	6.85707	7.08003
Directivity (dB)	-4.55073	-4.40541	-4.25964	-4.05731	-4.08739	-3.81536	-3.75126	-3.86044	-3.5579	-3.37009	-3.14376	-3.15004	-3.05175	-3.06105	-3.02605	-3.07481	-2.98452	-3.10055	-3.0202	-3.05986	-3.08747
Efficiency (%)	35.0693	36.2626	37.5004	39.2888	39.0177	41.5398	42.1575	41.1106	44.0768	46.0247	48.4668	48.4168	49.5251	49.4192	49.8191	49.2627	50.2977	48.9717	49.8862	49.4327	49.1194
Gain (dBi)	1.20984	2.08284	1.8628	1.94327	2.00509	2.4364	2.6474	2.59458	3.2405	2.8257	3.40825	3.49819	3.32397	3.55919	3.52257	3.72068	3.38846	3.26432	3.72578	3.79721	3.99256

7. Test method

Full anechoic chamber

Passive test



8. Calibration

Using the standard dipole antenna, measure the path loss with Network Analyzer.

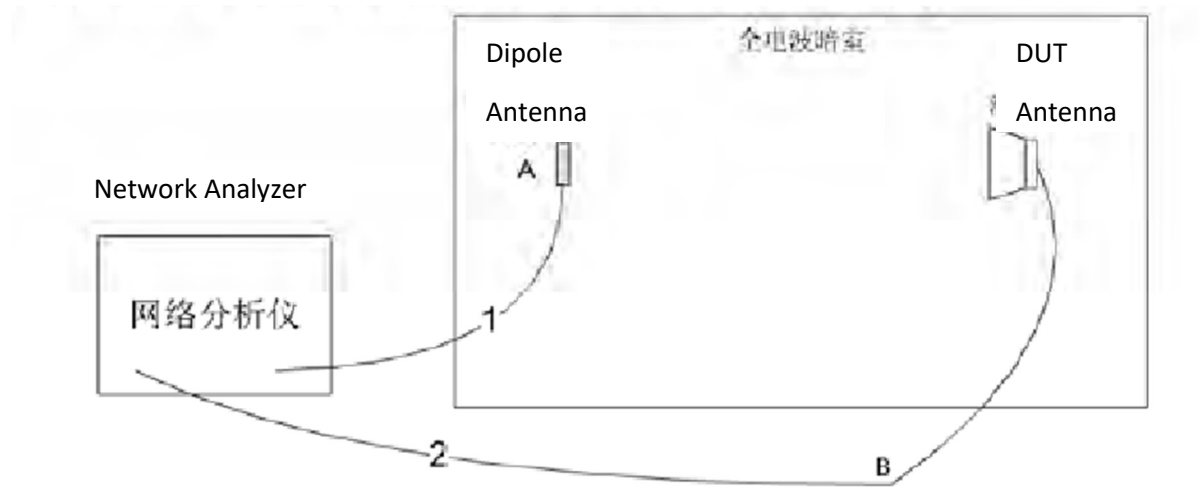

- According to the frequency range to be calibrated, select a suitable dipole antenna, and replace the EUT with the dipole antenna, place it at point A, adjust the polarization direction of its position to make it consistent with the polarization direction to be calibrated, and Align its strongest radiation direction with the measuring antenna.
- Connect one port of network analyzer to the dipole antenna through cable 1, and connect the other port to point B through cable 2, measure the S21 between the two ports of network analyzer under this configuration, and denoted as L1
- Disconnect cable 1 from dipole antenna, disconnect cable 2 from point B, and connect cable 1 and cable 2. Measure the S21 between the two ports of the network analyzer under this configuration, denoted as L2.
- Calculate the path loss of the system at this frequency point and polarization direction as: $PL=L1-L2-G$

PL: Path loss

G: Gain of dipole antenna at this frequency

- At all measurement frequency points of TIRP and TIRS, repeat the above steps in two polarization direction to obtain the path loss in all test frequency bands and polarization

9. Test Equipment

Network Analyzer; Switch; Turntable controller; Standard dipole antenna

10. Summary

- The BLE Antennas used are PCB Printed , Inverted F type antenna
- It is Omni directional pattern
- It is internal antenna.